

TECHNICAL MANUAL

VOLUME 3 OF 3

PART 3 OF 4

MAINTENANCE

ORGANIZATIONAL LEVEL

2 ½-TON, 6X6, M44A1 AND M44A2 SERIES TRUCKS  
(MULTIFUEL)

TRUCK, CARGO: M35A1,  
M35A2, M35A2C, M36A2; TRUCK,  
TANK, FUEL: M49A1C, M49A2C; TRUCK, TANK,  
WATER: M50A1, M50A2, M50A3; TRUCK, VAN,  
SHOP: M109A2, M109A3; TRUCK, REPAIR SHOP:  
M185A2, M185A3; TRUCK, TRACTOR: M275A1,  
M275A2; TRUCK, DUMP: M342A2; TRUCK,  
MAINTENANCE, PIPELINE CONSTRUCTION:  
M756A2; TRUCK, MAINTENANCE,  
EARTH BORING AND POLESETTING: M764

Chapter 18 Body, Cab and Hull
-------------------------------------

**NOTE:**

THE STYLE OF THIS TM IS  
EXPERIMENTAL. IT IS BEING TRIED  
BY THE ARMY ONLY ON  
A LIMITED BASIS

---

DEPARTMENTS OF THE ARMY AND THE AIR FORCE

MAY 1981



WARNING

EXHAUST GASES CAN BE DEADLY

Exposure to exhaust gases produces symptoms of headache, dizziness, loss of muscular control, apparent drowsiness, and coma. Permanent brain damage or death can result from severe exposure.

Carbon monoxide occurs in the exhaust fumes of fuel burning heaters and internal combustion engines, and becomes dangerously concentrated under conditions of inadequate ventilation. The following precautions must be observed to insure the safety of personnel whenever fuel burning heater(s) or engine of any vehicle is operated for maintenance purposes or tactical use.

Do not operate heater or engine of vehicle in an enclosed area unless it is adequately ventilated.

Do not idle engine for long periods without maintaining adequate ventilation in personnel compartments.

Do not drive any vehicle with inspection plates or cover plates removed unless necessary for maintenance purposes.

Be alert at all times during vehicle operation for exhaust odors and exposure symptoms. If either are present, immediately ventilate personnel compartments. If symptoms persist, remove affected personnel from vehicle and treat as follows: expose to fresh air; keep warm; do not permit physical exercise; if necessary, administer artificial respiration.

If exposed, seek prompt medical attention for possible delayed onset of acute lung congestion. Administer oxygen if available.

WARNING

Serious or fatal injury to personnel may result if the following instructions are not complied with.

Dry cleaning solvent is flammable. Do not use near an open flame. Keep a fire extinguisher nearby when solvent is used. Use only in well-ventilated places. Failure to do this may result in injury to personnel and damage to equipment.

Eye shields must be worn when using compressed air. Eye injury can occur if eye shields are not used.

Smoking, sparks, or open flame are not allowed within 50 feet when working on fuel trucks. Fuel may burn, causing explosion, injury to personnel, and damage to equipment.

Always wear protective gloves when handling cable. Do not let cable slip through hands. Rusty or broken wires can cause injury.

Before working on circuit breaker box, disconnect 115-volt power cable to stop injury from electrical shock.

Be careful to hold van door up with hoist equipment. Van door is heavy and may fall and injure personnel.

WARNING - Cont

Denatured alcohol and adhesive are flammable. Do not use near an open flame. Keep a fire extinguisher nearby when solvent is used. Use only in well-ventilated places. Failure to do this may result in injury to personnel and damage to equipment.

Eye shields must be worn when using grinder. Eye injury can occur if eye shields are not used.

When unscrewing the last of four capscrews on the outrigger hydraulic pump, hold pump so that it does not fall and cause injury.

TM 9-2320-209-20-3-3

T.O. 36A12-1B-1092-1-3

DEPARTMENTS OF THE ARMY

AND

THE AIR FORCE

Washington, D.C., 27 May 1981

TECHNICAL MANUAL

NO. 9-2320-209-20-3-3

TECHNICAL ORDER

NO. 36A12-1B-1092-1-3

TECHNICAL MANUAL

VOLUME 3 OF 3

PART 3 OF 4

MAINTENANCE

ORGANIZATIONAL LEVEL

2 ½-TON 6X6, M44A1 AND M44A2 SERIES TRUCKS

(MULTIFUEL)

Model		NSN without Winch	NSN with Winch
Truck, Cargo	M35A1	2320-00-542-5633	2320-00-542-5634
	M35A2	2320-00-077-1616	2320-00-077-1617
	M35A2C	2320-00-926-0873	2320-00-926-0875
	M36A2	2320-00-077-1618	2320-00-077-1619
Truck, Tank, Fuel	M49A1C	2320-00-440-3349	2320-00-440-3346
	M49A2C	2320-00-077-1631	2320-00-077-1632
Truck, Tank, Water	M50A1	2320-00-440-8307	2320-00-440-8305
	M50A2	2320-00-077-1633	2320-00-077-1634
	M50A3	2320-00-937-4036	2320-00-937-5264
Truck, Van, Shop	M109A2	2320-00-440-8313	2320-00-440-8308
	M109A3	2320-00-077-1636	2320-00-077-1637
Truck, Repair Shop	M185A2	4940-00-987-8799	
	M185A3	4940-00-077-1638	4940-00-077-1639
Truck, Tractor	M275A1	2320-00-446-2479	
	M275A2	2320-00-077-1640	2320-00-077-1641
Truck, Dump	M342A2	2320-00-077-1643	2320-00-077-1644
Truck, Maintenance, Pipeline Construction	M756A2		2320-00-904-3277
Truck, Maintenance, Earth Boring and Polesetting	M764		2320-00-937-5980

\*This manual, together with TM 2320-209-20-1, 27 May 1981; TM 9-2320-209-20-2-1, 27 May 1981; TM 9-2320-209-20-2-2, 27 May 1981; TM 9-2320-209-20-3-1, 27 May 1981; TM 9-2320-209-20-3-2, 27 May 1981; and TM 9-2320-209-20-3-4, 27 May 1981, supersedes TM 9-2320-209-20-1, 31 August 1978.

**REPORTING OF ERRORS AND RECOMMENDING IMPROVEMENTS**

You can help improve this manual. If you find any mistakes or if you know of a way to improve the procedure, please let us know. Mail your letter, DA Form 2028 (Recommended Changes to Publications and Blank Forms), or DA Form 2028-2 located in the back of this manual direct to: Commander, US Army Tank-Automotive Command, ATTN: DRSTA-MB, Warren, Michigan 48090. A reply will be furnished to you.

## TABLE OF CONTENTS

	Paragraph	Page
<b>CHAPTER 18. BODY, CAB, HOOD, AND HULL GROUP MAINTENANCE</b>		
<b>Section I. Scope</b> .....		18-1
Equipment Items Covered ... ..	18-1	18-1
Equipment Items Not Covered .....	18-2	18-1
<b>Section II. Cab Components</b> .....		18-1
Cab Door Removal and Replacement .....	18-3	18-1
Removal .....	18-3a	18-2
Replacement .....	18-3b	18-3
Cab Door Repair .....	18-4	18-4
Disassembly .....	18-4a	18-4
Repair .....	18-4b	18-7
Assembly .....	18-4c	19-7
Cab Tunnel Removal and Replacement .....	18-5	18-10
Removal (Front, Intermediate and Rear Tunnels) .....	18-5a	18-10
Replacement (Front, Intermediate and Rear Tunnels) .....	18-5b	18-12
<b>Section III. Windshield Assembly</b> .....		18-14
Windshield Assembly Removal and Replacement .....	18-6	18-14
Preliminary Procedure .....	18-6a	18-14
Removal .....	18-6b	18-14
Replacement .....	18-6c	18-16
<b>Section IV. Seats</b> .....		18-18
Driver's Seat Removal and Replacement (Early Model Trucks) .....	18-7	18-18
Preliminary Procedure .....	18-7a	18-18
Removal .....	18-7b	18-18
Replacement .....	18-7c	18-19
Floating Driver's Seat Removal and Replacement .....	18-8	18-20
Removal .....	18-8a	18-20
Replacement .....	18-8b	18-21
Floating Driver's Seat Repair. ....	18-9	18-22
Preliminary Procedure .....	18-9a	18-22
Removal .....	18-9b	18-22
Replacement .....	18-9c	18-24

TABLE OF CONTENTS - CONT

	Paragraph	Page
Driver's Seat Repair (Trucks M35A1 and M49A2C) . . . . .	18-10	18-26
Removal . . . . .	18-10a	18-26
Replacement . . . . .	18-10b	18-28
Companion Seat Removal and Replacement (Later Model Trucks) . . . . .	18-11	18-30
Removal . . . . .	18-11a	18-30
Replacement . . . . .	18-11b	18-32
Companion Seat Removal and Replacement (Early Model Trucks) . . . . .	18-12	18-34
Removal . . . . .	18-12a	18-34
Replacement . . . . .	18-12b	18-36
Companion Seat Repair (Early Model Trucks) . . . . .	18-13	18-38
Removal . . . . .	18-13a	18-38
Replacement . . . . .	18-13b	18-42
Section V. Brackets and Straps . . . . .		18-46
Gasoline Drum Bracket Removal and Replacement . . . . .	18-14	18-46
Removal . . . . .	18-14a	18-46
Replacement . . . . .	18-14b	18-47
Webbing Strap Repair . . . . .	18-15	18-48
Section VI. Cargo Body Components . . . . .		18-48
Tailgate Assembly Removal and Replacement (All Cargo Trucks Except M35A2C) . . . . .	18-16	18-48
Removal . . . . .	18-16a	18-48
Replacement . . . . .	18-16b	18-50
Tailgate Assembly Removal and Replacement (Truck M35A2C) . . . . .	18-17	18-52
Removal . . . . .	18-17a	18-52
Replacement . . . . .	18-17b	18-54
Troop Seat Rack Assembly Repair . . . . .	18-18	18-56
Preliminary Procedure . . . . .	18-18a	18-56
Disassembly of Rack and Seat Assembly . . . . .	18-18b	18-56
Disassembly of Rack Assembly. . . . .	18-18c	18-57
Disassembly of Seat Assembly . . . . .	18-18d	18-58
Cleaning . . . . .	18-18e	18-60
Inspection and Repair . . . . .	18-18f	18-60
Assembly of Seat Assembly. . . . .	18-18g	18-61
Assembly of Rack Assembly . . . . .	18-18h	18-64
Assembly of Rack and Seat Assembly . . . . .	18-18i	18-66
Section VII. Tank Body Components . . . . .		18-67
Discharge Valve Assembly Removal and Replacement (Trucks M49A1C and M49A2C) . . . . .	18-19	18-67
Preliminary Procedure . . . . .	18-19a	18-67

TABLE OF CONTENTS - CONT

	Paragraph	Page
Removal .....	18-19b	18-67
Replacement .....	18-19c	18-70
Discharge Valve Packing Removal and Replacement (Trucks M49A1C and M49A2C) .....	18-20	18-73
Removal .....	18-20a	18-73
Replacement .....	18-20b	18-75
Discharge Pipes Removal and Replacement (Trucks M49A1C and M49A2C) .....	18-21	18-77
Preliminary Procedure .....	18-21a	18-77
Removal .....	18-21b	18-78
Replacement .....	18-21c	18-84
Gate Valve Removal and Replacement (Trucks M49A1C and M49A2C) .....	18-22	18-90
Removal .....	18-22a	18-90
Replacement .....	18-22b	18-91
Gate Valve Packing Removal and Replacement (Trucks M49A1C and M49A2C) .....	18-23	18-92
Removal .....	18-23a	18-92
Replacement .....	18-23b	18-93
Emergency Release Cable Removal and Replacement .....	18-24	18-94
Removal .....	18-24a	18-95
Replacement .....	18-24b	18-97
Front Discharge Valve Cable Removal and Replacement (Truck M49A1C) .....	18-25	18-101
Removal .....	18-25a	18-101
Replacement .....	18-25b	18-103
Front Discharge Valve Cable Removal and Replacement (Truck M49A2C) .....	18-26	18-106
Removal .....	18-26a	18-106
Replacement .....	18-26b	18-108
Intermediate Discharge Valve Cable Removal and Replacement (Truck M49A1C) .....	18-27	18-111
Removal .....	18-27a	18-111
Replacement .....	18-27b	18-113
Rear Discharge Valve Cable Removal and Replacement (Truck M49A1C) .....	18-28	18-116
Removal .....	18-28a	18-116
Replacement .....	18-28b	18-118



TABLE OF CONTENTS - CONT

	Paragraph	Page
Rear Discharge Valve Cable		
Removal and Replacement		
(Truck M49A2C) . . . . .	18-29	18-120
Removal . . . . .	18-29a	18-120
Replacement . . . . .	18-29b	18-122
Fusible Link Removal and		
Replacement . . . . .	18-30	18-125
Removal . . . . .	18-30a	18-125
Replacement . . . . .	18-30b	18-127
Globe Valve Removal and Replacement . . . . .	18-31	18-129
Removal . . . . .	18-31a	18-129
Replacement . . . . .	18-31b	18-132
Discharge Valve Operating Lever		
Removal and Replacement . . . . .	18-32	18-134
Removal . . . . .	18-32a	18-134
Replacement . . . . .	18-32b	18-136
Centrifugal Pump Removal and		
Replacement (Trucks M49A1C		
and M49A2C) . . . . .	18-33	18-138
Removal . . . . .	18-33a	18-138
Replacement . . . . .	18-33b	18-143
Delivery Pump Strainer and Gasket		
Removal and Replacement . . . . .	18-34	18-149
Removal . . . . .	18-34a	18-149
Replacement . . . . .	18-34b	18-151
Delivery Pump Propeller Shafts		
Removal and Replacement (Trucks		
M49A1C and M49A2C) . . . . .	18-35	18-152
Removal . . . . .	18-35a	18-152
Repair . . . . .	18-35b	18-160
Replacement . . . . .	18-35c	18-160
Pump Drive Shaft Bearing and Journal		
Universal Removal and Replacement . . . . .	18-36	18-167
Preliminary Procedure . . . . .	18-36a	18-167
Removal . . . . .	18-36b	18-167
Replacement . . . . .	18-36c	18-170
Fuel Drain Manifold Removal and		
Replacement (Truck M49A2C)		
Preliminary Procedure . . . . .	18-37	18-172
Removal . . . . .	18-37a	18-172
Cleaning and Inspection . . . . .	18-37b	18-172
Replacement . . . . .	18-37c	18-176
Replacement . . . . .	18-37d	18-177
Pump-to-Manifold Hose Removal and		
Replacement (Trucks M49A1C and		
M49A2C) . . . . .	18-38	18-181
Removal . . . . .	18-38a	18-181
Replacement . . . . .	18-38b	18-184

## TABLE OF CONTENTS - CONT

	Paragraph	Page
Water Segregator Unit Removal, Repair, and Replacement (Truck M49A1C) . . . . .	18-39	18-187
Removal . . . . .	18-39a	18-188
Repair . . . . .	18-39b	18-192
Replacement . . . . .	18-39c	18-194
Water Segregator Unit Service (Truck M49A2C) . . . . .	18-40	18-197
Water Segregator Filter Element (Truck M49A1C) Removal and Replacement . . . . .	18-41	18-198
Removal . . . . .	18-41a	18-199
Replacement . . . . .	18-41b	18-207
Water Segregator Filters and Go/No-Go Fuses Removal and Replacement (Truck M49A2C) . . . . .	18-42	18-215
Removal . . . . .	18-42a	18-215
Cleaning . . . . .	18-42b	18-219
Replacement . . . . .	18-42c	18-219
Static Reel Assembly Removal and Replacement (Truck M49A1C) . . . . .	18-43	18-223
Removal . . . . .	18-43a	18-223
Replacement . . . . .	18-43b	18-224
Static Reel Assembly Removal and Replacement (Truck M49A2C) . . . . .	18-44	18-225
Removal . . . . .	18-44a	18-225
Replacement . . . . .	18-44b	18-226
Static Reel Assembly Repair (Trucks M49A1C and M49A2C). . . . .	18-45	18-227
Disassembly . . . . .	18-45a	18-227
Assembly . . . . .	18-45b	18-228
Gallon Indicating Meter Removal and Replacement (Truck M49A1C) . . . . .	18-46	18-229
Preliminary Procedure . . . . .	18-46a	18-229
Removal . . . . .	18-46b	18-229
Replacement . . . . .	18-46c	18-233
Gallon Indicating Meter Removal and Replacement (Truck M49A2C) . . . . .	18-47	18-238
Removal . . . . .	18-47a	18-238
Replacement . . . . .	18-47b	18-242
Hose and Nozzle Assembly Removal and Replacement . . . . .	18-48	18-245
Removal . . . . .	18-48a	18-245
Replacement . . . . .	18-48b	18-248

TABLE OF CONTENTS - CONT

	Paragraph	Page
Hose Coupling Gasket Removal and Replacement (Truck M49A1C) . . . . .	18-49	18-251
Removal . . . . .	18-49a	18-251
Replacement . . . . .	18-49b	18-253
Hose Coupling Gasket Removal and Replacement (Truck M49A2C). . . . .	18-50	18-255
Removal . . . . .	18-50a	18-255
Replacement . . . . .	18-50b	18-257
Manhole Cover Removal and Replacement (Trucks M49A1C and M49A2C) . . . . .	18-51	18-259
Removal . . . . .	18-51a	18-259
Replacement . . . . .	18-51b	18-260
Manhold Cover Repair . . . . .	18-52	18-261
Preliminary Procedure . . . . .	18-52a	18-261
Disassembly . . . . .	18-52b	18-261
Inspection and Repair . . . . .	18-52c	18-262
Assembly . . . . .	18-52d	18-262
Discharge Valve Removal and Replacement (Trucks M50A1, M50A2, and M50A3) . . . . .	18-53	18-263
Preliminary Procedure . . . . .	18-53a	18-263
Removal . . . . .	18-53b	18-264
Replacement . . . . .	18-53c	18-168
Discharge Valve Packing Removal and Replacement (Trucks M50A1, M50A2, and M50A3) . . . . .	18-54	18-272
Preliminary Procedures . . . . .	18-54a	18-272
Removal . . . . .	18-54b	18-272
Replacement . . . . .	18-54c	18-274
Discharge Valve Control Levers Removal and Replacement (Trucks M50A1, M50A2, and M50A3) . . . . .	18-55	18-276
Preliminary Procedure . . . . .	18-55a	18-276
Removal . . . . .	18-55b	18-276
Replacement . . . . .	18-55c	18-278
Front and Rear Discharge Valve Cables Removal and Replacement (Trucks M50A1, M50A2, and M50A3) . . . . .	18-56	18-280
Preliminary Procedure . . . . .	18-56a	18-280
Removal . . . . .	18-56b	18-280
Replacement . . . . .	18-56c	18-284
Discharge Pipe Removal and Replacement (Trucks M50A1, M50A2, and M50A3) . . . . .	18-57	18-289
Preliminary Procedure . . . . .	18-57a	18-289
Removal . . . . .	18-57b	18-290
Replacement . . . . .	18-57c	18-302

TABLE OF CONTENTS - CONT

	Paragraph	Page
Delivery Pump Removal and Replacement (Trucks M50A1, M40A2, and M50A3) .....	18-58	18-314
Removal .....	18-58a	18-314
Replacement .....	18-58b	18-318
Delivery Pump Drive Shaft Removal, Repair, and Replacement .....	18-59	18-323
Removal .....	18-59a	18-323
Repair .....	18-59b	18-328
Replacement .....	18-59c	18-330
Dispenser Hose Assembly Removal and Replacement (Trucks M50A1, M50A2, and M50A3) .....	18-60	18-337
Removal .....	18-60a	18-337
Replacement .....	18-60b	18-338
Water Discharge Hoses, Dispenser Nozzle, and Suction Strainer Removal and Replacement (Trucks M50A1, M50A2, and M50A3) .....	18-61	18-339
Preliminary Procedure .....	18-61a	18-339
Removal .....	18-61b	18-339
Replacement .....	18-61c	18-341
Manhole Covers Removal and Replacement (Trucks M5A1 and M50A2) .....	18-62	18-343
Removal of Outer Manhole Cover .....	18-62a	18-343
Removal of Inner Manhold Cover .....	18-62b	18-344
Repair of Inner Manhold Cover .....	18-62c	18-345
Repair of Outer Manhold Cover .....	18-62d	18-347
Replacement of Inner Manhole Cover .....	18-62e	18-348
Replacement of Outer Manhoe Cover .....	18-62f	18-351
Manhole Cover Removal, Repair, and Replacement (Truck M50A3) .....	18-63	18-352
Removal .....	18-63a	18-352
Repair .....	18-63b	18-353
Replacement .....	18-63c	18-354
Water Tank Filler Cover Removal, Repair, and Replacement (Trucks M50A1, M50A2, and M50A3) .....	18-64	18-357
Removal .....	18-64a	18-357
Cleaning .....	18-64b	18-358
Inspection and Repair .....	18-64c	18-358
Replacement .....	18-64d	18-358

TABLE OF CONTENTS - CONT

	Paragraph	Page
Section VIII. Special Purpose Bodies		
24-Volt and 115-Volt Dome Light Assemblies Removal and Replacement (Trucks M109A2, M109A3, M185A2, and M185A3) . . . . .	18-65	18-359
Preliminary Procedures . . . . .	18-65a	18-359
Removal . . . . .	18-65b	18-359
Replacement . . . . .	18-65c	18-361
24-Volt Dome Light Lamp Removal and Replacement (Trucks M109A2, M109A3, M185A2, and M185A3) . . . . .	18-66	18-363
Preliminary Procedures . . . . .	18-66a	18-363
Removal . . . . .	18-66b	18-363
Replacement . . . . .	18-66c	18-364
115-Volt Dome Light Lamp Removal and Replacement (Trucks M109A2, M109A3, M185A2, and M185A3) . . . . .	18-67	18-365
Preliminary Procedure . . . . .	18-67a	18-365
Removal . . . . .	18-67b	18-365
Replacement . . . . .	18-67c	18-366
Power Switch Fuse Removal and Replacement (Trucks M185A2 and M185A3) . . . . .	18-68	18-367
Preliminary Procedures . . . . .	18-68a	18-367
Removal . . . . .	18-68b	18-367
Replacement . . . . .	18-68c	18-368
24-Volt Circuit Breaker Removal and Replacement . . . . .	18-69	18-369
Preliminary Procedure . . . . .	18-69a	18-369
Removal . . . . .	18-69b	18-369
Replacement . . . . .	18-69c	18-370
115-Volt Circuit Breaker Removal and Replacement . . . . .	18-70	18-371
Removal . . . . .	18-70a	18-371
Replacement . . . . .	18-70b	18-373
115-Volt Dome Light Switch Removal and Replacement . . . . .	18-71	18-375
Preliminary Procedures . . . . .	18-71a	18-375
Removal . . . . .	18-71b	18-375
Replacement . . . . .	18-71c	18-377
24-Volt Dome Light and Blackout Dome Light Toggle Switches Removal and Replacement (Trucks M109A2 and M109A3) . . . . .	18-72	18-380
Preliminary Procedure . . . . .	18-72a	18-380
Removal . . . . .	18-72b	18-381
Replacement . . . . .	18-72c	18-385

TABLE OF CONTENTS - CONT

	Paragraph	Page
24-Volt and 115-Volt Van Rear Door Blackout Switches Removal and Replacement . . . . .	18-73	18-389
Preliminary Procedures. . . . .	18-73a	18-389
Removal . . . . .	18-73b	18-389
Replacement . . . . .	18-73c	18-391
Exhaust Blower Assembly Removal and Replacement (Trucks M109A2 and M109A3) . . . . .	18-74	18-393
Removal . . . . .	18-74a	18-393
Replacement . . . . .	18-74b	18-395
Van Door Assembly Removal and Replacement (Trucks M109A2, M109A3, M185A2, and M185A3) . . . . .	18-75	18-397
Preliminary Procedure. . . . .	18-75a	18-397
Removal . . . . .	18-75b	18-397
Replacement . . . . .	18-75c	18-400
Door Seals Removal and Replacement (Trucks M109A2, M109A3, M185A2, and M185A3) . . . . .	18-76	18-403
Removal . . . . .	18-76a	18-403
Replacement . . . . .	18-76b	18-405
Van Door Repair (Trucks M109A2, M109A3, M185A2, M185A3) . . . . .	18-77	18-406
Preliminary Procedure . . . . .	18-77a	18-406
Disassembly . . . . .	18-77b	18-407
Cleaning . . . . .	18-77c	18-413
Inspection and Repair . . . . .	18-77d	18-414
Assembly . . . . .	18-77e	18-416
Horizontal Leveling Worm Drive Chain Removal and Replacement (Truck M764) . . . . .	18-78	18-422
Removal . . . . .	18-78a	18-422
Replacement . . . . .	18-78b	18-425
Vertical Leveling Worm Drive Chain Removal and Replacement (Truck M764) . . . . .	18-79	18-428
Removal . . . . .	18-79a	18-428
Replacement . . . . .	18-79b	18-431
Leveling Worm Drive Chain Adjustment (Truck M764) . . . . .	18-80	18-434
Preliminary Procedure . . . . .	18-80a	18-434
Adjustment . . . . .	18-80b	18-435
Roller Drive Chain Repair . . . . .	18-81	18-436
Preliminary Procedures . . . . .	18-81a	18-436
Repair . . . . .	18-81b	18-437

## TABLE OF CONTENTS - CONT

	Paragraph	Page
Earth Boring Machine Drive Shaft		
Assembly Removal and Replacement . . . . .	18-82	18-438
Removal . . . . .	18-82a	18-438
Replacement . . . . .	18-82b	18-439
Cab Protector Upper Section Removal		
and Replacement (Truck M764) . . . . .	18-83	18-441
Preliminary Procedures . . . . .	18-83a	18-441
Removal . . . . .	18-83b	18-441
Replacement . . . . .	18-83c	18-442
Outrigger Hydraulic Lines and Fittings		
Removal and Replacement (Truck		
M764) . . . . .	18-84	18-443
Preliminary Procedure . . . . .	18-84a	18-443
Removal . . . . .	18-84b	18-444
Replacement . . . . .	18-84c	18-451
Outrigger Hydraulic Pump Removal		
and Replacement (Truck M764) . . . . .	18-85	18-459
Removal . . . . .	18-85a	18-459
Replacement . . . . .	18-85b	18-463
Outrigger Control Valve Removal and		
Replacement (Truck M764) . . . . .	18-86	18-467
Preliminary Procedure . . . . .	18-86a	18-467
Removal . . . . .	18-86b	18-467
Replacement . . . . .	18-86c	18-470
Power Leveler Repair (Truck M764). . . . .	18-87	18-473
Removal . . . . .	18-87a	18-473
Cleaning . . . . .	18-87b	18-474
Inspection and Repair . . . . .	18-87c	18-474
Replacement . . . . .	18-87d	18-474
A-Frame Gin Pole and Clamp Assembly		
Removal, Repair, and Replacement		
(Truck M756A2) . . . . .	18-88	18-475
Preliminary Procedure . . . . .	18-88a	18-475
Removal . . . . .	18-88b	18-476
Repair . . . . .	18-88c	18-479
Replacement . . . . .	18-88d	18-479
A-Frame Sheave Assembly Disassembly		
and Assembly (Truck M756A2). . . . .	18-89	18-482
Preliminary Procedure . . . . .	18-89a	18-482
Disassembly . . . . .	18-89b	18-483
Assembly . . . . .	18-89c	18-485
Tool Box Removal and Replacement		
(Truck M756A2) . . . . .	18-90	18-487
Removal . . . . .	18-90a	18-487
Replacement . . . . .	18-90b	18-495

## TABLE OF CONTENTS-CONT

	Paragraph	Page
Rear Splash Guards Removal and		
Replacement (Truck M756A2) . . . . .	18-91	18-504
Removal . . . . .	18-91a	18-504
Replacement . . . . .	18-91b	18-505
Auxiliary Roller Bracket Assembly		
Removal, Repair, and Replacement		
(Truck M756A2) . . . . .	18-92	18-507
Removal . . . . .	18-92a	18-507
Repair . . . . .	18-92b	18-509
Replacement . . . . .	18-92c	18-509
Tailboard Roller Assembly Removal,		
Repair, and Replacement		
(Truck M756A2) . . . . .	18-93	18-511
Preliminary Procedures . . . . .	18-93a	18-511
Removal . . . . .	18-93b	18-512
Repair . . . . .	18-93c	18-514
Replacement . . . . .	18-93d	18-514
Stiffleg Jack Assembly Removal, Repair,		
and Replacement (Truck M756A2) . . . . .	18-94	18-517
Removal . . . . .	18-94a	18-517
Repair . . . . .	18-94b	18-519
Replacement . . . . .	18-94c	18-519
Snatch Sheave Removal and		
Replacement (Truck M764) . . . . .	18-95	18-521
Removal . . . . .	18-95a	18-521
Replacement . . . . .	18-95b	18-522



# CHAPTER 18

## BODY, CAB, HOOD, AND HULL GROUP MAINTENANCE

---

### Section I. SCOPE

18-1. EQUIPMENT ITEMS COVERED. This chapter gives equipment maintenance procedures for cab components, windshield assembly, seats, brackets and straps, cargo body components, tank body components, and special purpose bodies for which there are authorized corrective maintenance tasks at the organizational maintenance level.

18-2. EQUIPMENT ITEMS NOT COVERED. All equipment items for which corrective maintenance is authorized at the organizational maintenance level are covered in this chapter.

### Section II. CAB COMPONENTS

#### 18-3. CAB DOOR REMOVAL AND REPLACEMENT.

##### NOTE

This task is the same for the left and right cab doors. This task is shown for the right cab door.

TOOLS: Medium size hammer  
1/8-inch pin punch  
Pliers

SUPPLIES: None

PERSONNEL: Two

EQUIPMENT CONDITION: Truck parked, engine off, handbrake set.

a. Removal.

FRAME 1

1. Open door (1) to first catch. Working inside cab and using pliers, take out and throw away cotter pin (2).

Soldier A 2. Hold door (1).

Soldier B 3. Using hammer and punch, drive out two hinge pins (3).

Soldiers 4. Take off door (1).  
A and B

END OF TASK

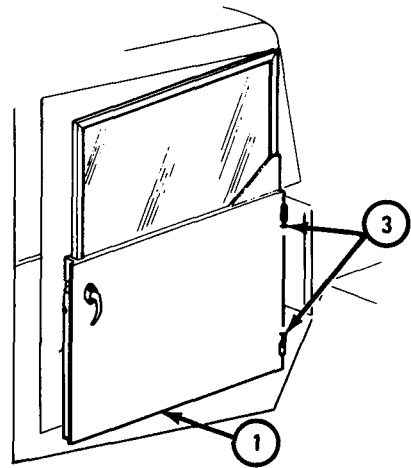
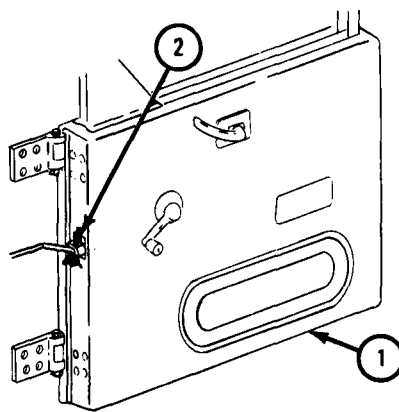
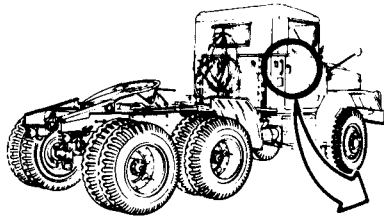

TA 103389

b. Replacement.

**FRAME 1**

Soldiers 1. Put door (1) in place, alining hinges (2). Close door.  
A and B

Soldier A 2. Using hammer, tap in two hinge pins (3).

3. Open door (1). Working inside cab and using pliers, put in and bend open ends of cotter pin (4).

END OF TASK

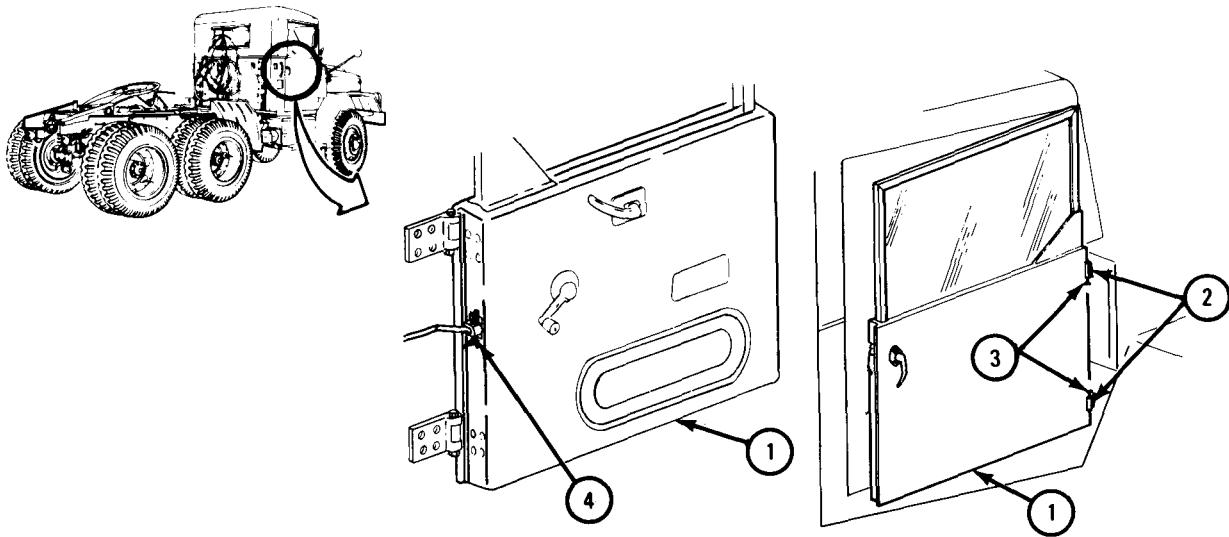

TA 103388

18-4. CAB DOOR REPAIR.

NOTE

This procedure shows right door. Procedure for left door is same.

TOOLS: Flat-tip screwdriver  
Cross-tip screwdriver (Phillips type)

SUPPLIES : None

PERSONNEL: One

EQUIPMENT CONDITION: Truck parked, engine off, handbrake set.

a. Disassembly.

FRAME 1

1. Turn door handle (1) and open cab door (2).
2. Using flat-tip screwdriver, unscrew and take out two oval head screws (3).
3. Pull handle (1) out of door (2).

GO TO FRAME 2

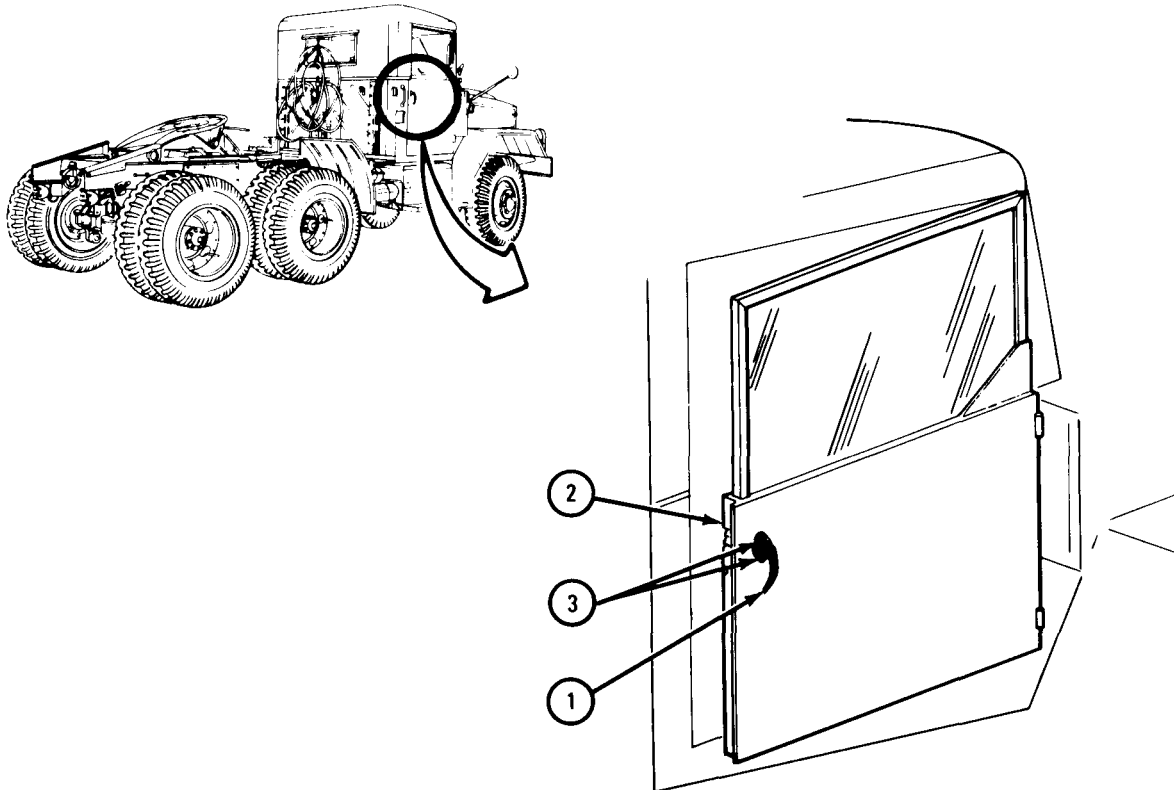

TA 101753

FRAME 2

1. Turn window handle (1) to the left until window (2) is down.
2. Using flat-tip screwdriver, unscrew and take out two screws (3).
3. Take off window handle (1), door handle (4), and two washers (5).
4. Using phillips screwdriver, unscrew and take out two screws (6). Take out dovetail (7) and shim (8).
5. Using flat-tip screwdriver, unscrew and take out six screws (9). Take off inspection cover (10).

GO TO FRAME 3

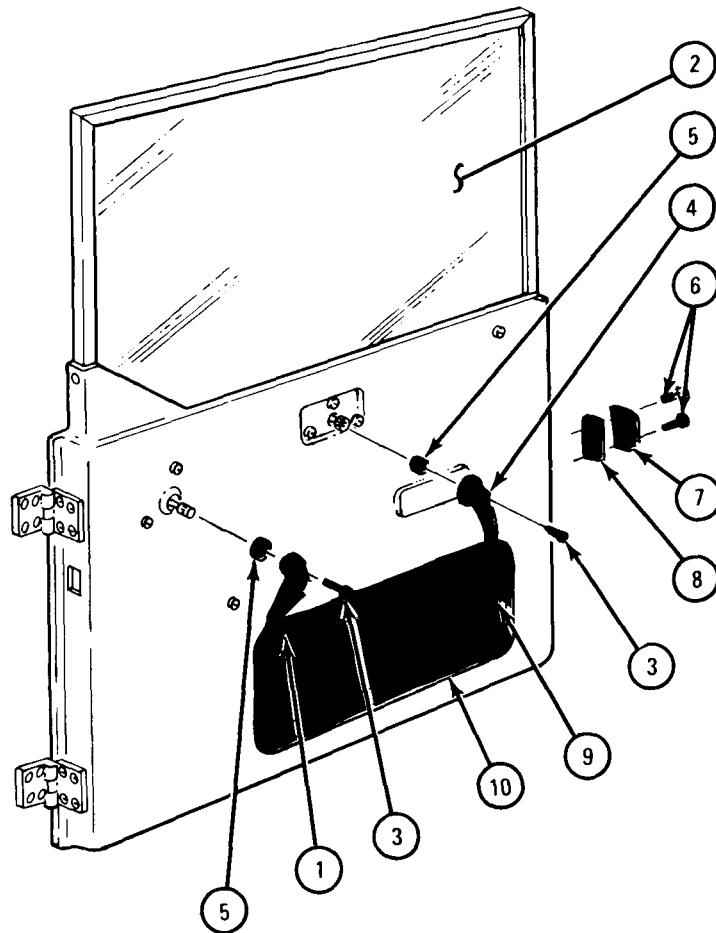

TA 087009

FRAME 3

1. Working through inspection hole (1) using phillips screwdriver, unscrew and take out four screws (2). Take off two window stops (3).

END OF TASK

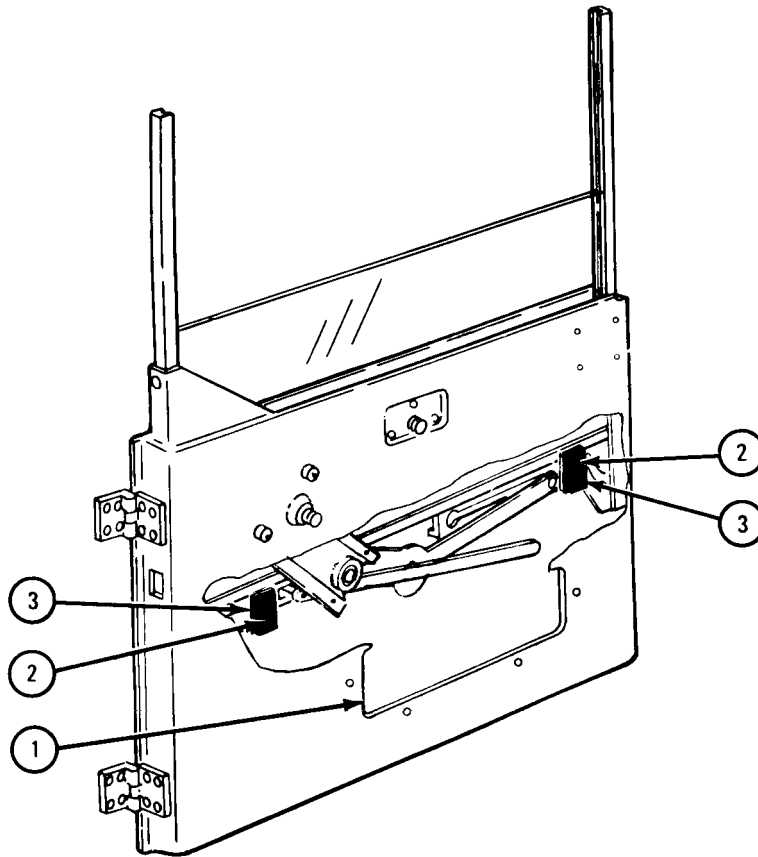

TA 101749

- b. Repair. Repair of cab door is limited to replacement of damaged parts.
- c. Assembly.

**FRAME 1**

1. Working through inspection hole (1), put two window stops (2) into place and align screw holes. Using phillips screwdriver, screw in and tighten four screws (3).

GO TO FRAME 2

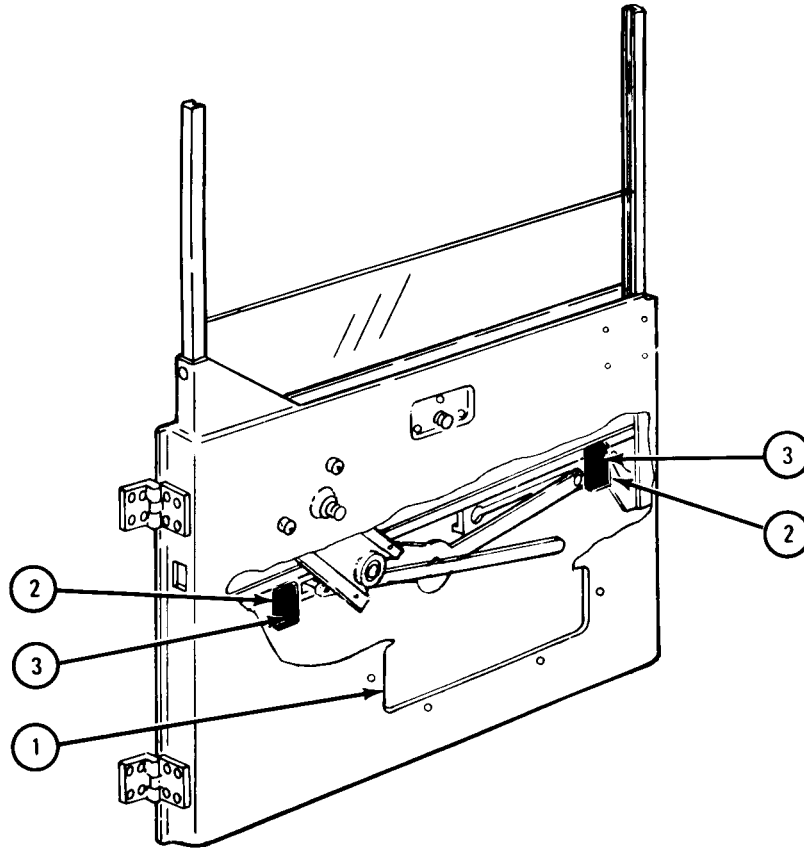

TA 101750

FRAME 2

1. Put inspection cover (1) in place and align screw holes. Using flat-tip screwdriver, screw in and tighten six screws (2).
  2. Put on two washers (3), door handle (4), and window handle (5). Using flat-tip screwdriver, screw in and tighten two screws (6).
  3. Put shims (7) and dovetail (8) in place and align screw holes. Using phillips screwdriver, screw in and tighten two screws (9).
  4. Turn window handle (5) to the right until window (10) is all the way up.
- GO TO FRAME 3

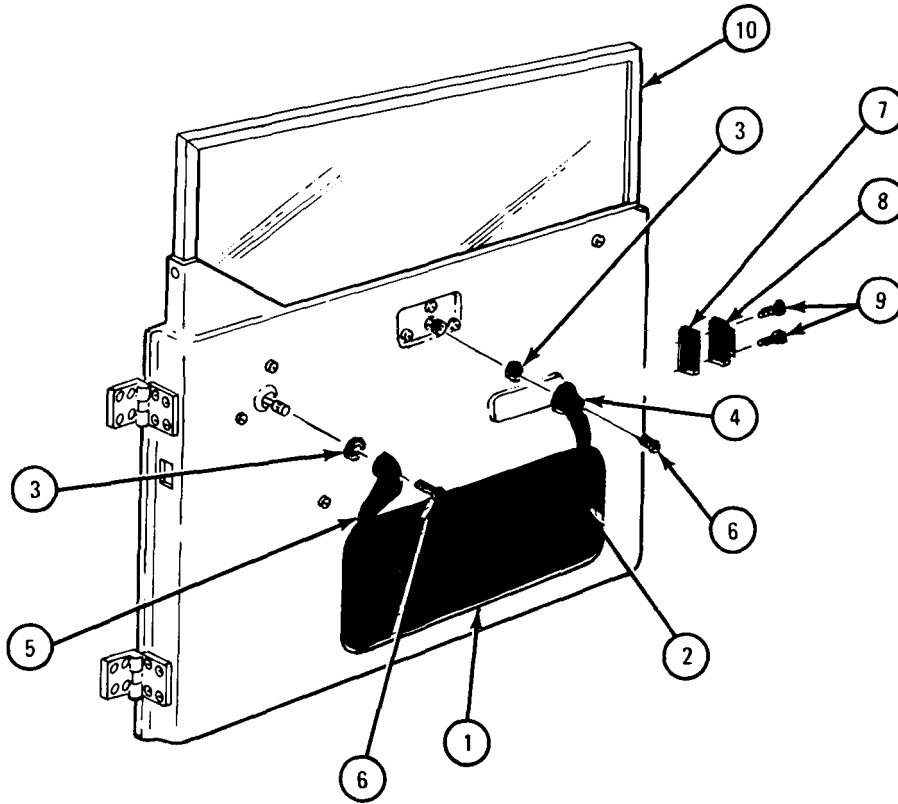

TA 101751



## FRAME 3

1. Put door handle (1) into outside of door (2). Using flat-tip screwdriver, screw in and tighten two oval head screws (3).

END OF TASK

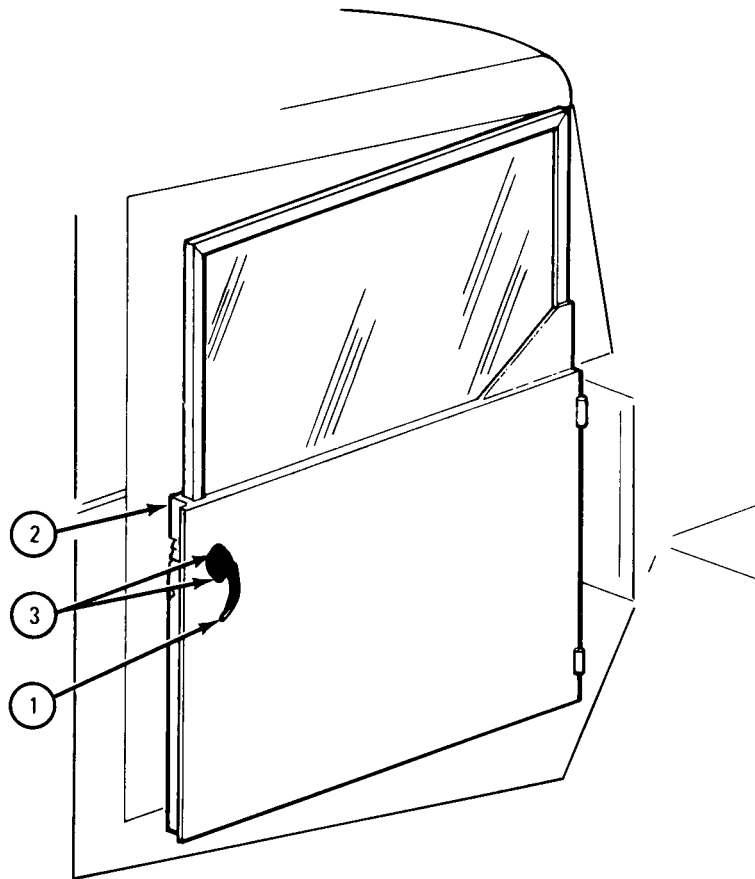

TA 101752

18-5. CAB TUNNEL REMOVAL AND REPLACEMENT.

TOOLS: 7/16-inch wrench  
11/16-inch open end wrench  
5/8-inch open end wrench

SUPPLIES: None

PERSONNEL: One

EQUIPMENT CONDITION: Truck parked, engine off, handbrake set.

a. Removal (Front, Intermediate, and Rear Tunnels).

FRAME 1

1. Slide rubber boot (1) up gear shift lever (2) as shown.
2. Using 11/16-inch and 5/8-inch wrenches, unscrew nut with flat washer (3) from bolt (4). Take out bolt and lift off gear shift lever (2).

GO TO FRAME 2

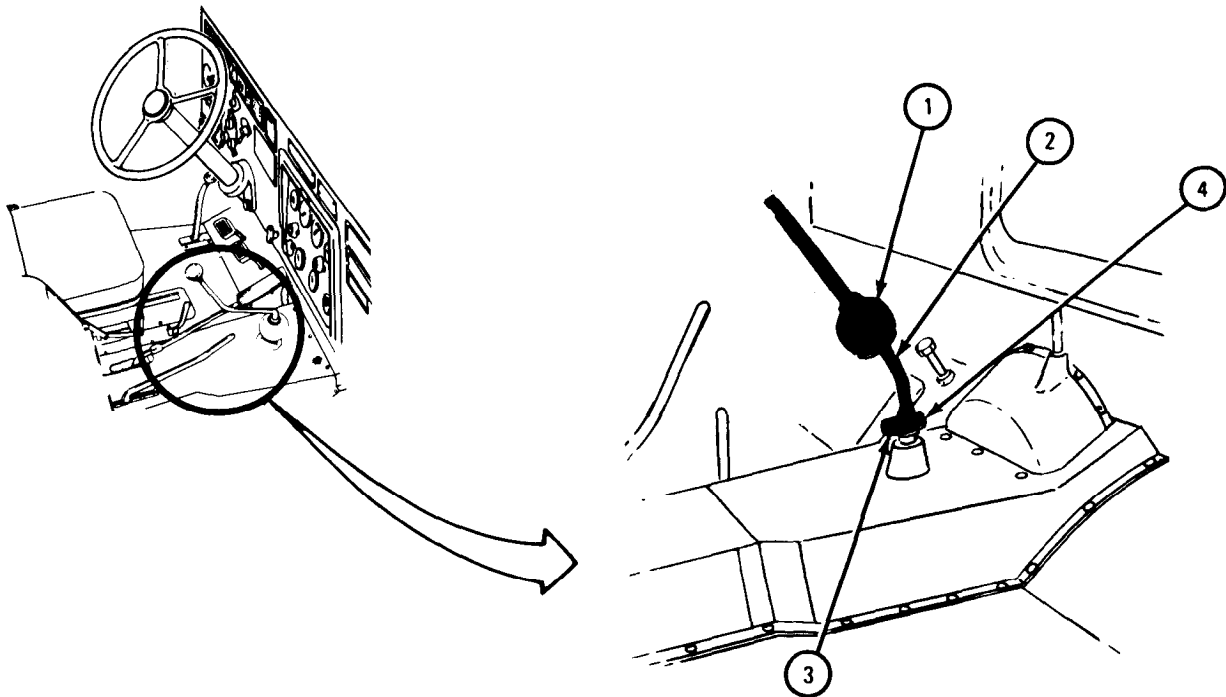

TA 047329

**FRAME 2**

1. Using 7/16-inch wrench, unscrew 13 screws (1). Screws hold intermediate tunnel (2) to front tunnel (3), cab floor (4), and rear tunnel (5)
2. Lift off intermediate tunnel (2) and take it out of cab.
3. Using 7/16-inch wrench, unscrew eight screws (6) holding front tunnel (3).
4. Lift off front tunnel (3) and take it out of cab.
5. Using 7/16-inch wrench, unscrew seven screws (7) holding rear tunnel (5). Lift off rear tunnel and take it out of cab.

END OF TASK

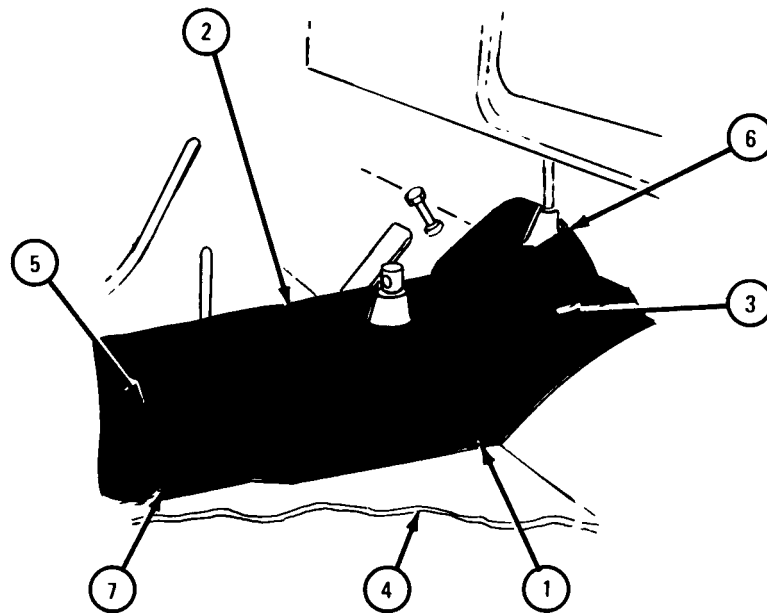

TA 047330

b. Replacement (Front, Intermediate, and Rear Tunnels).

**FRAME 1**

1. Place front tunnel (1) as shown and aline mounting holes. Using 7/16-inch wrench, screw in eight screws (2).
2. Place rear tunnel (3) as shown and aline mounting holes. Using 7/16-inch wrench, screw in seven screws (4).
3. Place intermediate tunnel (5) over front tunnel (1) and rear tunnel (3) as shown. Aline mounting holes and using 7/16-inch wrench, screw in 13 screws.

GO TO FRAME 2

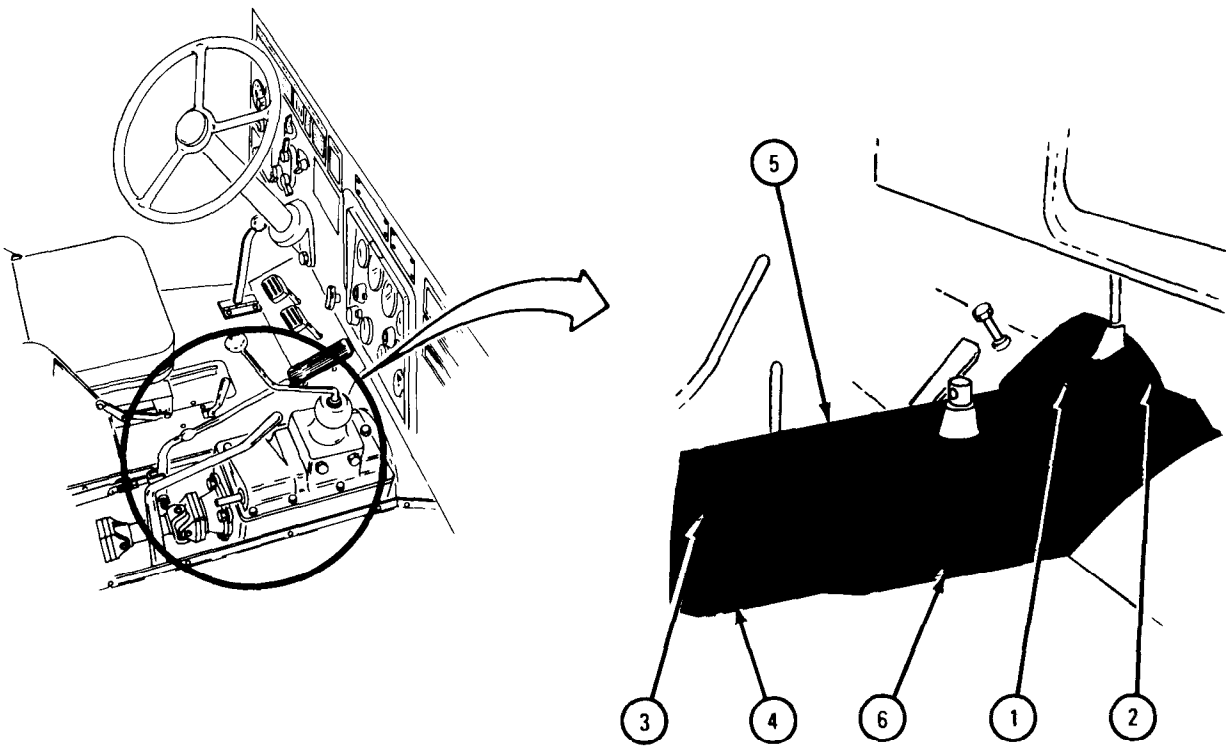

TA 047348

## FRAME 2

1. Put gear shift lever (1) over stub shaft (2).
2. Put bolt (3) through split flange holes at bottom of gear shift lever (1).
3. Using 5/8-inch and 11/16-inch wrenches, screw on locknut and flat washer (4).
4. Slide rubber boot (5) down over end of gear shift lever (1).

END OF TASK

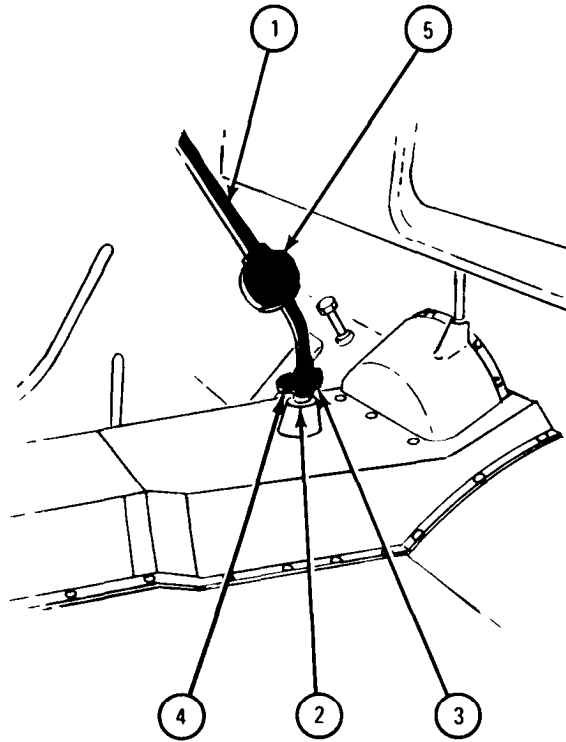

TA 047349

Section III. WINDSHIELD ASSEMBLY

18-6. WINDSHIELD ASSEMBLY REMOVAL AND REPLACEMENT.

TOOLS: Flat-tip screwdriver, heavy duty  
3/8-inch wrench

SUPPLIES: None

PERSONNEL: One

EQUIPMENT CONDITION: Truck parked, engine off, handbrake set.

a. Preliminary Procedure. Remove windshield wiper motors. Refer to Part 4, para 21-4.

b. Removal.

FRAME 1

1. Working in cab, lift up windshield lock handle (1).
2. Unscrew two windshield arm thumbscrews (2) partway.
3. Open windshield (3) by pushing bottom toward front of truck.
4. Tighten two windshield arm thumbscrews (2).

GO TO FRAME 2

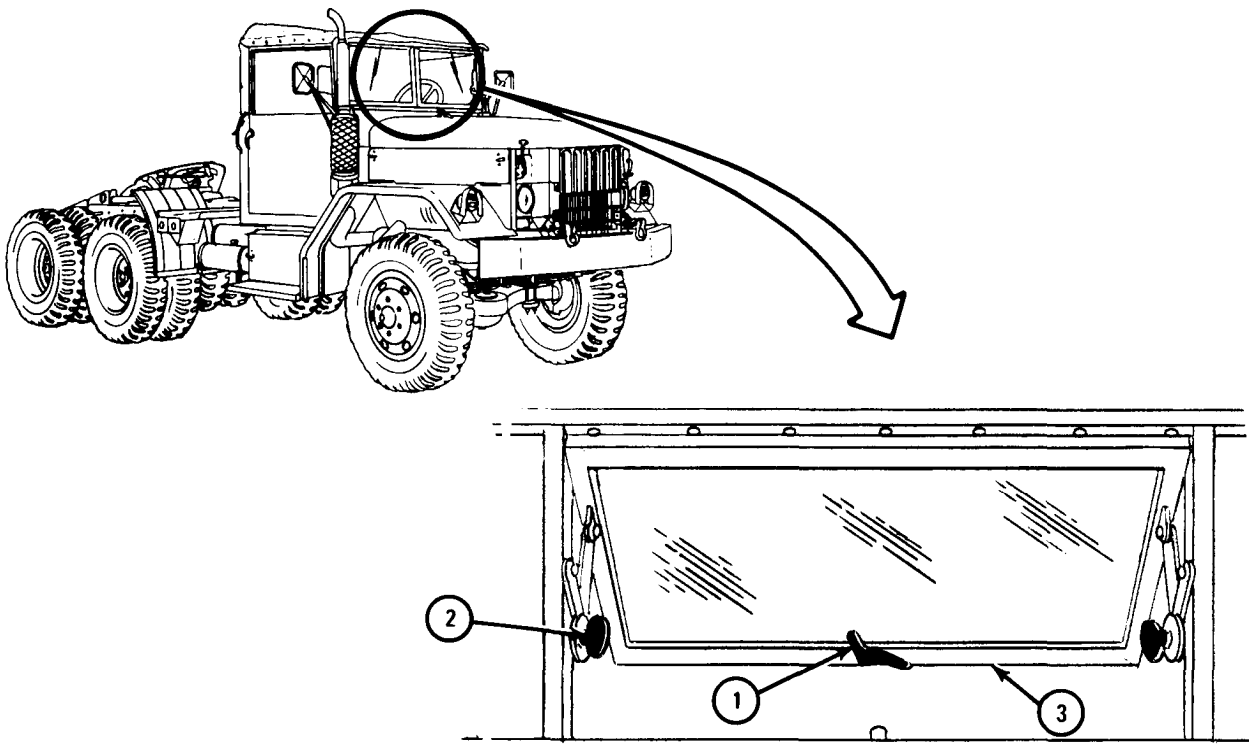

TA 046208

## FRAME 2

1. Using screwdriver, unscrew and take out two screws (1) and washers (2).
2. Using wrench, unscrew and take out seven screws (3). Hold windshield (4) so it does not fall down. Take away windshield.

END OF TASK

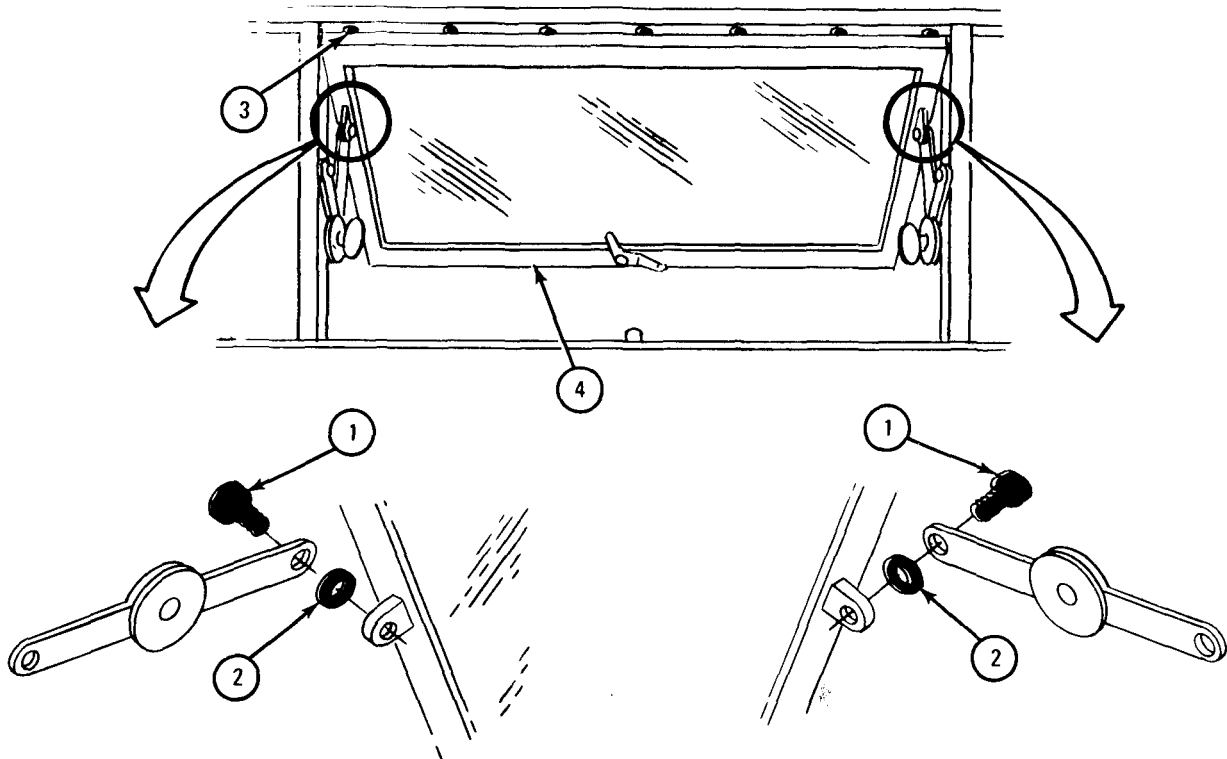

TA 046209

c. Replacement.

**FRAME 1**

1. Working in cab, put windshield hinge (1) up against crossmember (2). Line up screw holes. Using wrench, screw in and tighten seven screws (3).

GO TO FRAME 2

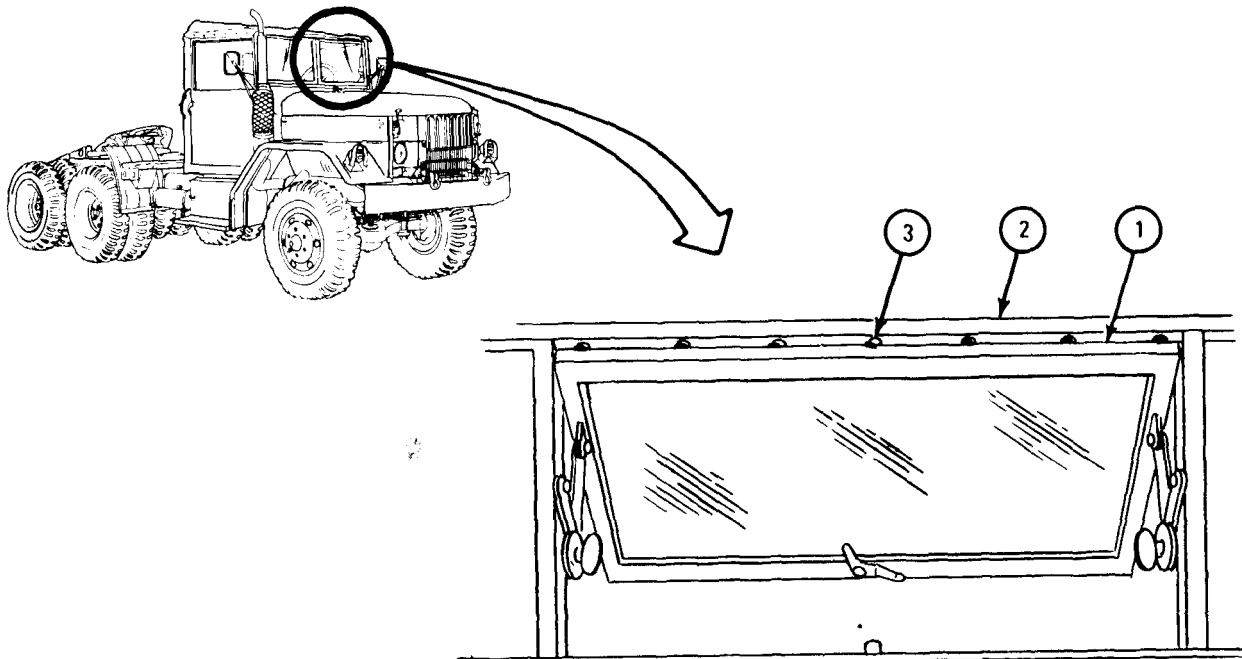

TA 046210



## FRAME 2

1. Put washers (1) between windshield arms (2) and arm anchors (3) in two places. Line up screw holes. Using screwdriver, screw in and tighten two screws (4).
2. Unscrew windshield arm thumbscrews (5) partway.
3. Using windshield lock handle (6), pull windshield closed. Push windshield lock handle down.

## NOTE

Follow-on Maintenance Action Required:

Replace windshield wiper motors. Refer to Part 4, para 21-4.

END OF TASK

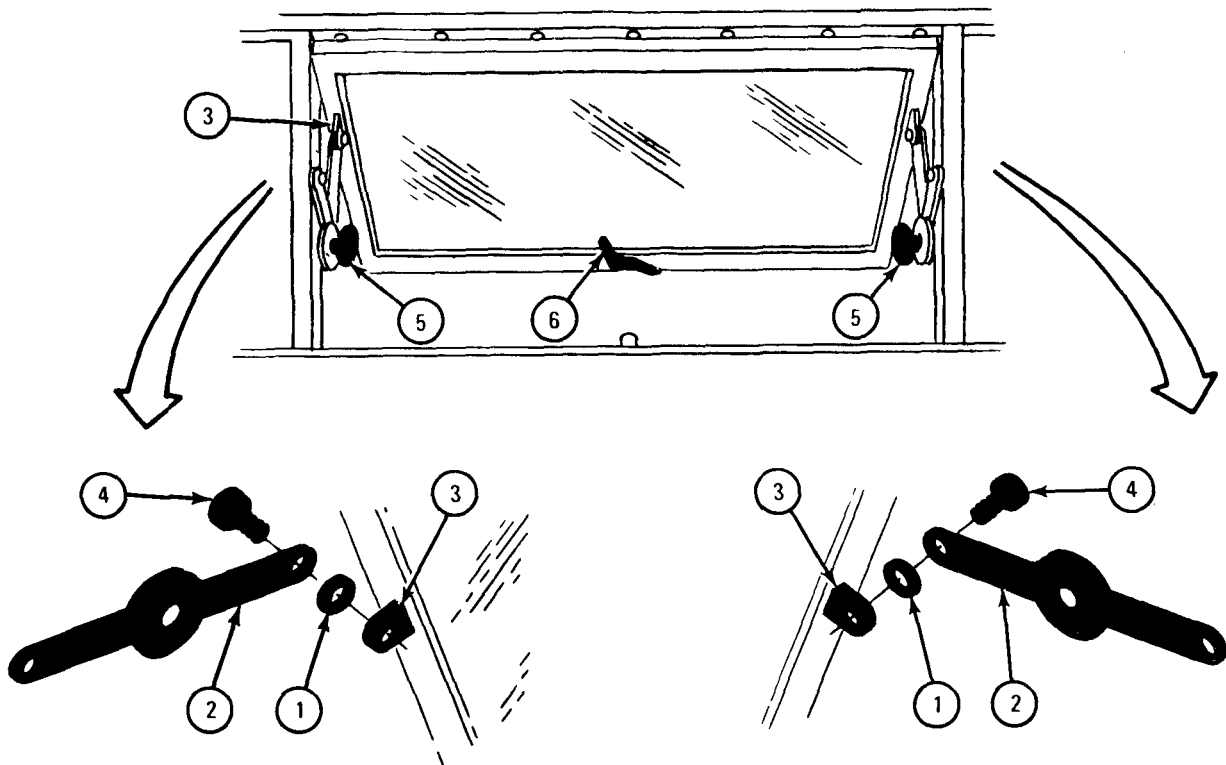

TA 046160

Section IV. SEATS

18-7. DRIVER'S SEAT REMOVAL AND REPLACEMENT (EARLY MODEL TRUCKS).

TOOLS: 9/16-inch wrench

SUPPLIES: None

PERSONNEL: One

EQUIPMENT CONDITION: Truck parked, engine off, handbrake set.

a. Preliminary Procedure. Remove companion seat. Refer to para 18-12.

b. Removal.

FRAME 1

1. Lift up driver's seat cushion (1).
2. Using 9/16-inch wrench, unscrew and take off four nuts (2) and four washers (3).
3. Pull out adjuster locking handle (4). Lift seat frame (5) off seat frame base (6) and take out four washers (7).

END OF TASK

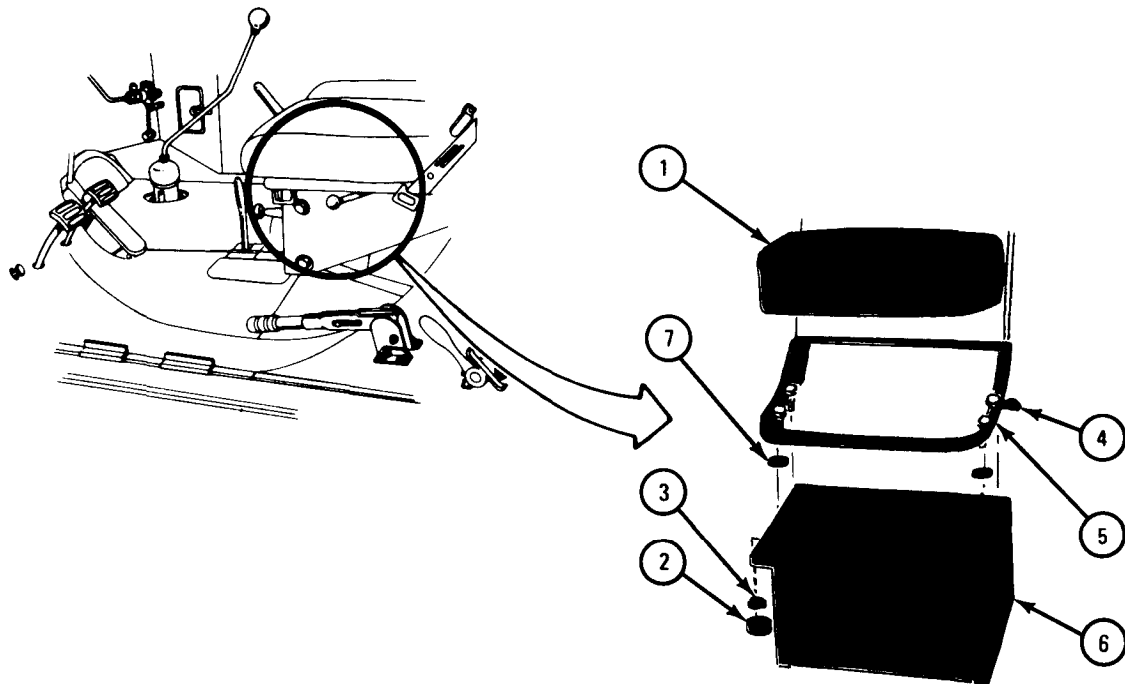

TA 046211

c. Replacement.**FRAME 1**

1. Put four washers (1) in place on seat frame base (2).
2. Pull out seat adjusting handle (3). Put seat frame (4) on seat frame base (2) and let go of handle.
3. Lift up seat cushion (5).
4. Screw on four nuts (6) and four washers (7).

## NOTE

Do not tighten nuts (6) all the way. The seat will not slide if nuts are too tight.

5. Using 9/16-inch wrench, tighten four nuts (6). Put down seat cushion (5).

## NOTE

Follow-on Maintenance Action Required:

Replace companion seat. Refer to para 18-12.

END OF TASK

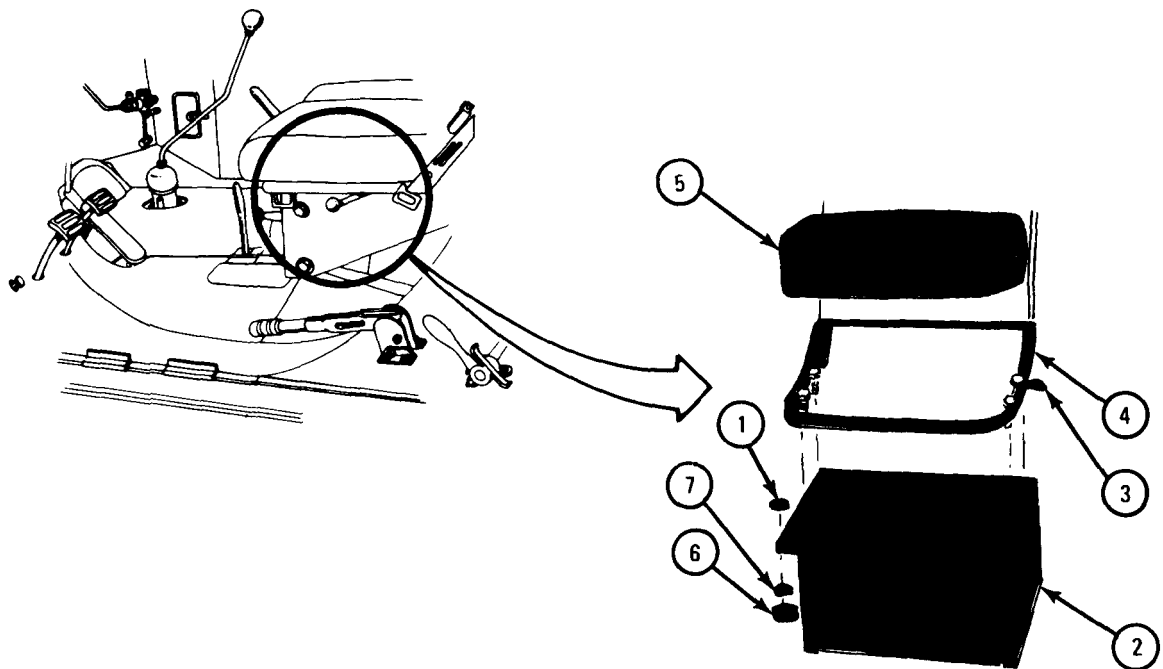

TA 046212

18-8. FLOATING DRIVER'S SEAT REMOVAL AND REPLACEMENT.

TOOLS: 9/16-inch wrench

SUPPLIES: None

PERSONNEL: One

EQUIPMENT CONDITION: Truck parked, engine off, handbrake set.

a. Removal.

FRAME 1

1. Using wrench, unscrew and take out four screws (1) and washers (2).

2. Take out driver's seat (3).

END OF TASK

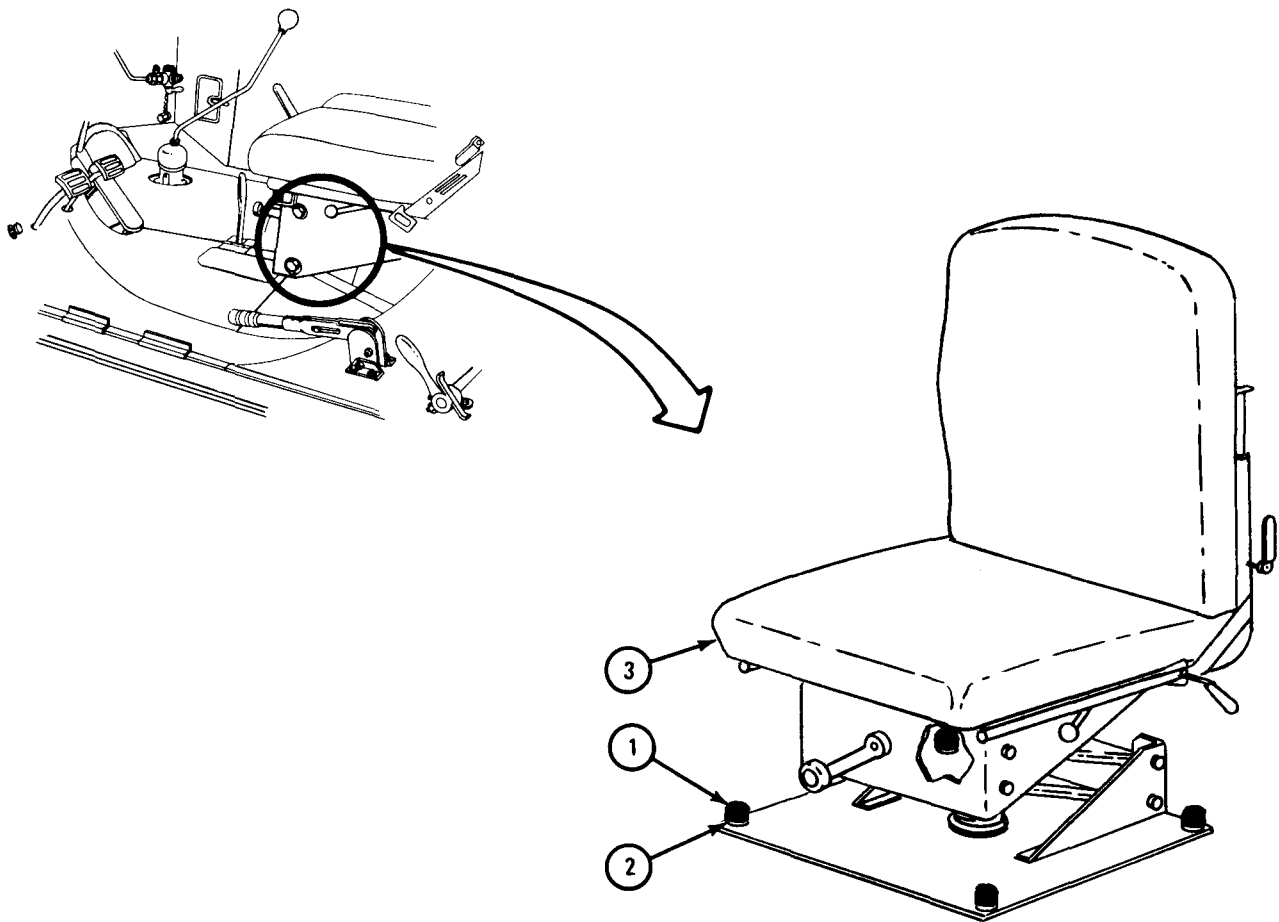

TA 046231

b. Replacement.

## FRAME 1

1. Put driver's seat (1) in cab of truck. Line up four mounting holes.
2. Put washers (2) on four screws (3). Using wrench, screw in and tighten screws.

END OF TASK

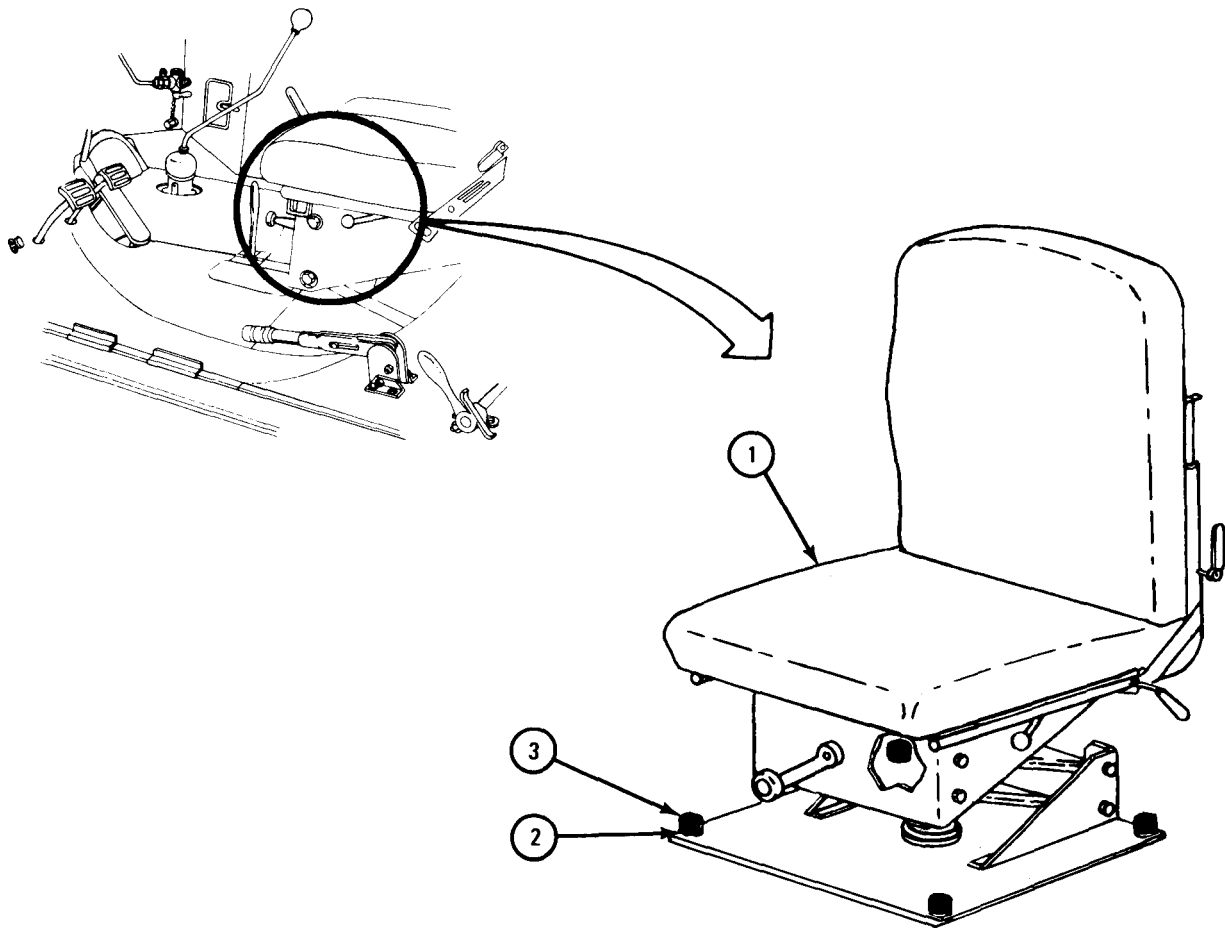

TA 046232

18-9. FLOATING DRIVER'S SEAT REPAIR.

TOOLS: Cross-tip screwdriver (Phillips type)

SUPPLIES: None

PERSONNEL: One

EQUIPMENT CONDITION: Truck parked, engine off, handbrake set.

NOTE

Repair of driver's seat is limited to removal and replacement of back rest and seat cushions.

a. Preliminary Procedure. Remove driver's seat from truck. Refer to para 18-8.

b. Removal.

FRAME 1

1. Using screwdriver, unscrew and take out four screws (1). Take off four lockwashers (2).

2. Take off seat cushion (3).

GO TO FRAME 2

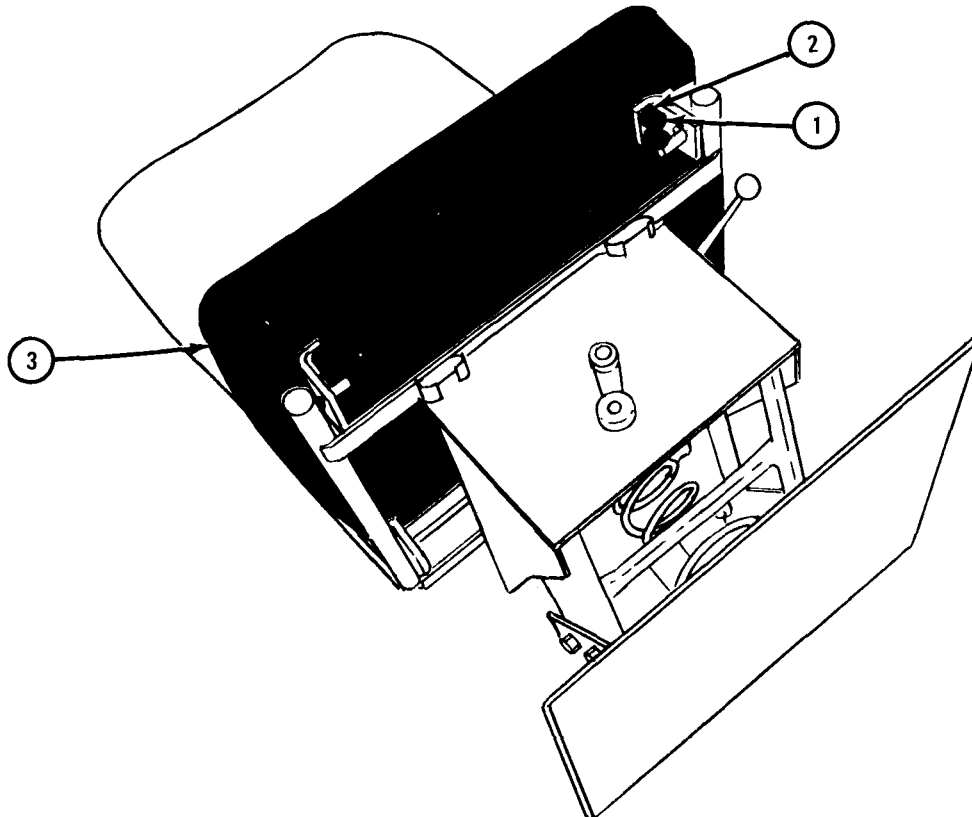

TA 046234

## FRAME 2

1. Using screwdriver, unscrew and take out four screws and lockwashers (1).  
Take off wear plate (2).
2. Using screwdriver, unscrew and take out two screws (3).
3. Take off back rest (4).

END OF TASK

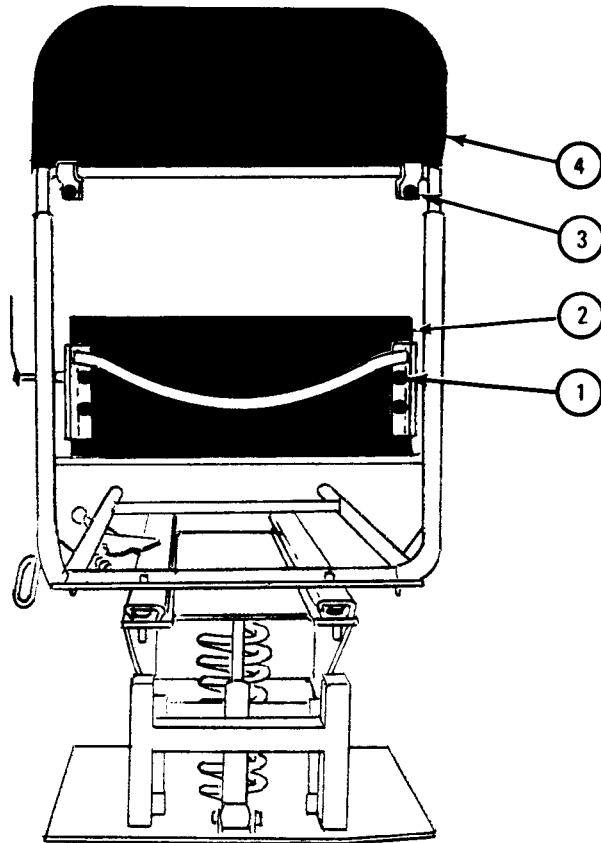

TA 046235

c. Replacement.

**FRAME 1**

1. Put back rest (1) in position.
2. Line up mounting holes in bracket (2) and back rest (1). Using phillips screwdriver, screw in and tighten two screws (3).
3. Put wear plate (4) between back rest (1) and brackets (5). Line up mounting holes. Using screwdriver, screw in and tighten four screws and lockwashers (6).

GO TO FRAME 2

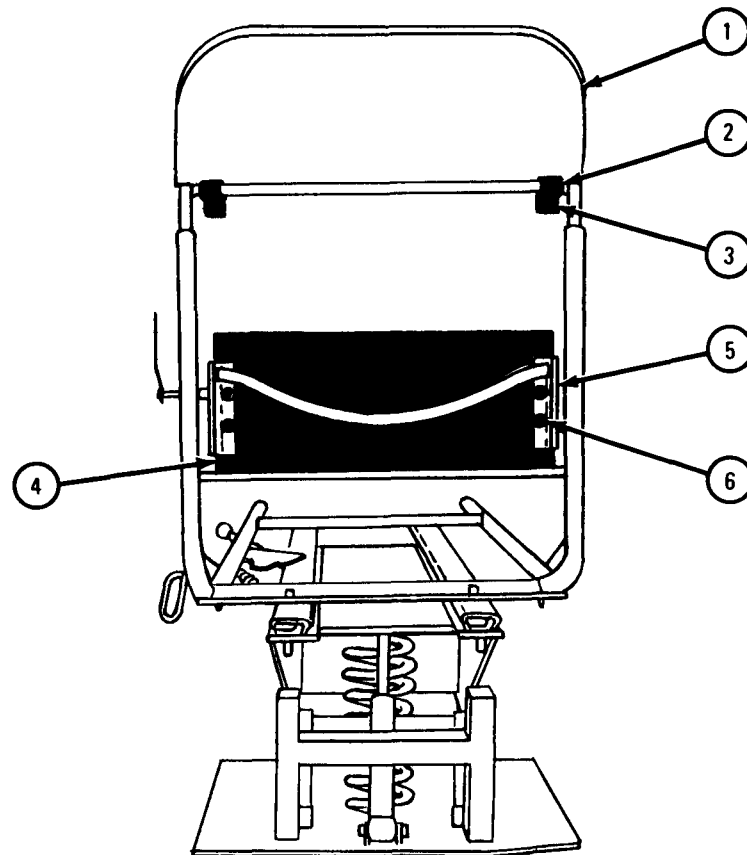

TA 046236



**FRAME 2**

1. Put seat cushion (1) in position. Line up mounting holes in bracket (2) and seat cushion.
2. Put lockwashers (3) on four screws (4). Using screwdriver, screw in and tighten screws.

**NOTE**

Follow-on Maintenance Action Required:

Replace driver's seat in truck. Refer to para 18-8.

END OF TASK

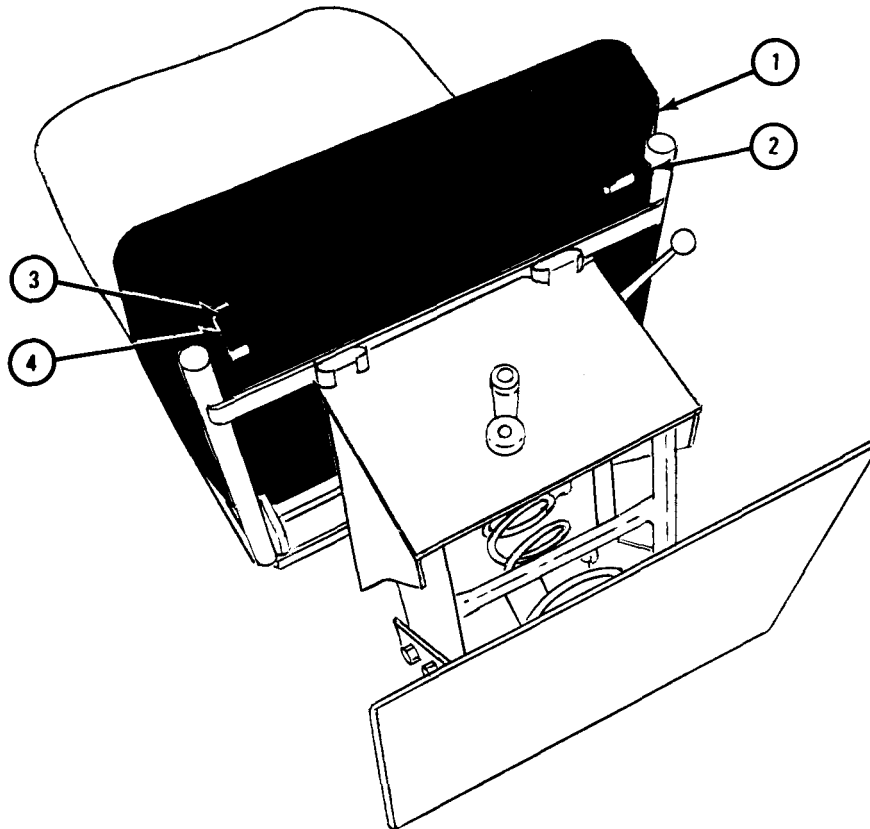

TA 046237

18-10. DRIVER'S SEAT REPAIR (TRUCKS M35A1 and M49A2C).

TOOLS: 1/2-inch wrench  
Flat-tip screwdriver

SUPPLIES: None

PERSONNEL: One

EQUIPMENT CONDITION: Truck parked, engine off, handbrake set.

NOTE

Repair of driver's seat is limited to removal and replacement of back rest and seat cushions.

a. Removal.

**FRAME 1**

1. Working in cab of truck, slide driver's back rest cushion (1) up and off frame (2).

GO TO FRAME 2

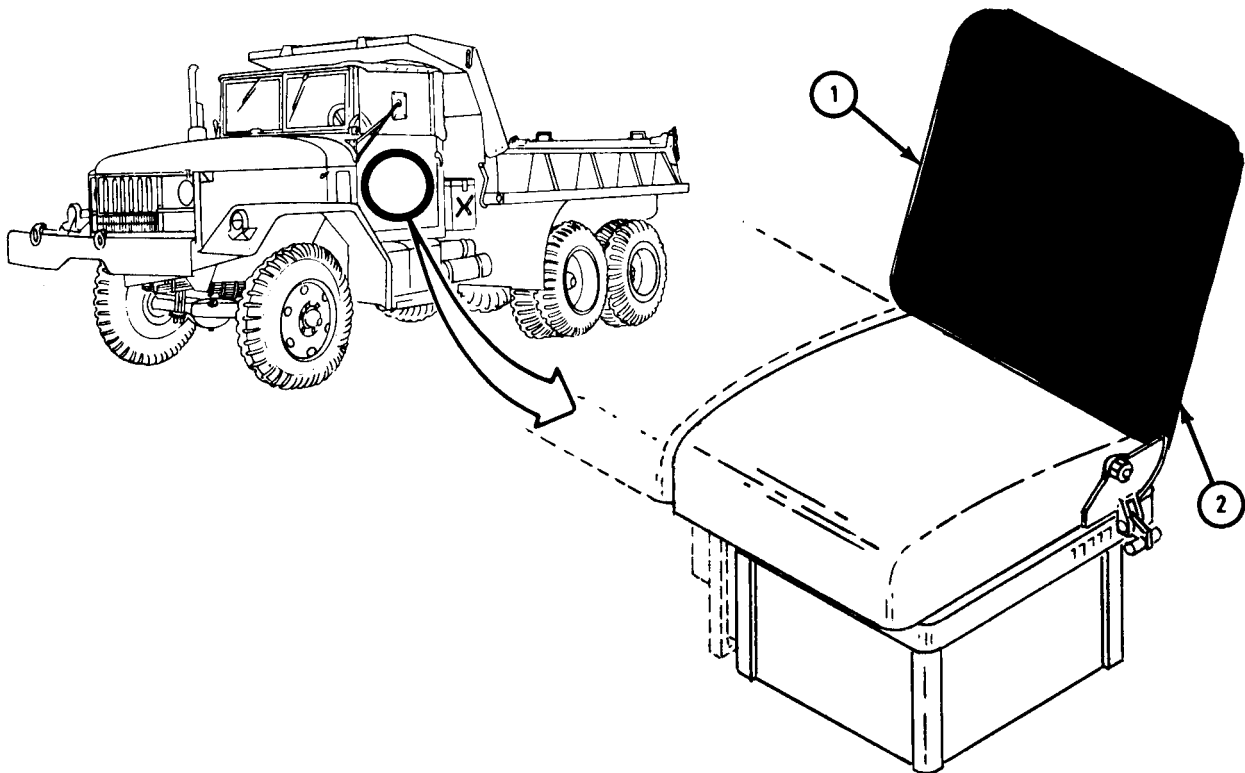

TA 046217

## FRAME 2

1. Push down on seat cushion (1) and using screwdriver, hold two screws (2).
2. Using 1/2-inch wrench and screwdriver, unscrew and take off two screws (2) and two nuts (3).
3. Take off seat cushion (1).

END OF TASK

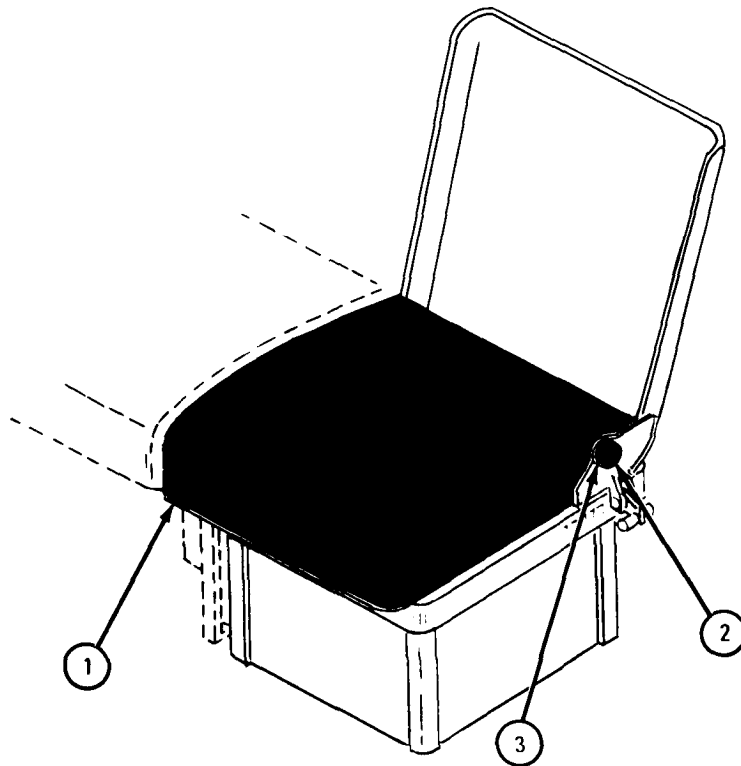

TA 046218

b. Replacement.

FRAME 1

1. Put seat cushion in place as shown.
2. Push down on seat cushion (1) and put two screws (2) through hole in two hinges (3). Screw on two nuts (4).

NOTE

Do not tighten nuts (4) so that seat cannot be tilted.

3. Push down on seat cushion and using screwdriver, hold two screws (2). Using 1/2-inch wrench, tighten two nuts (4).

GO TO FRAME 2

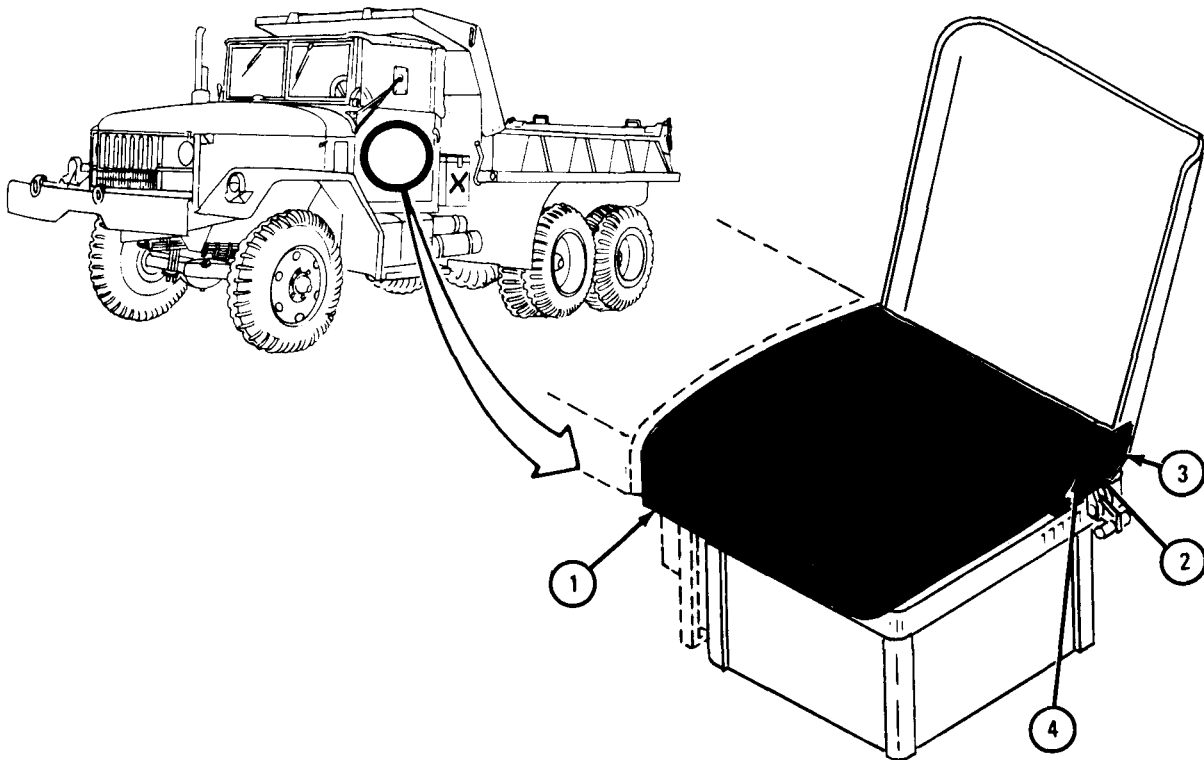

TA 046220

**FRAME 2**

1. Put bottom of back rest cushion (1) on top of frame (2). Slide back rest cushion down onto frame. Make sure top of cushion is held by frame.

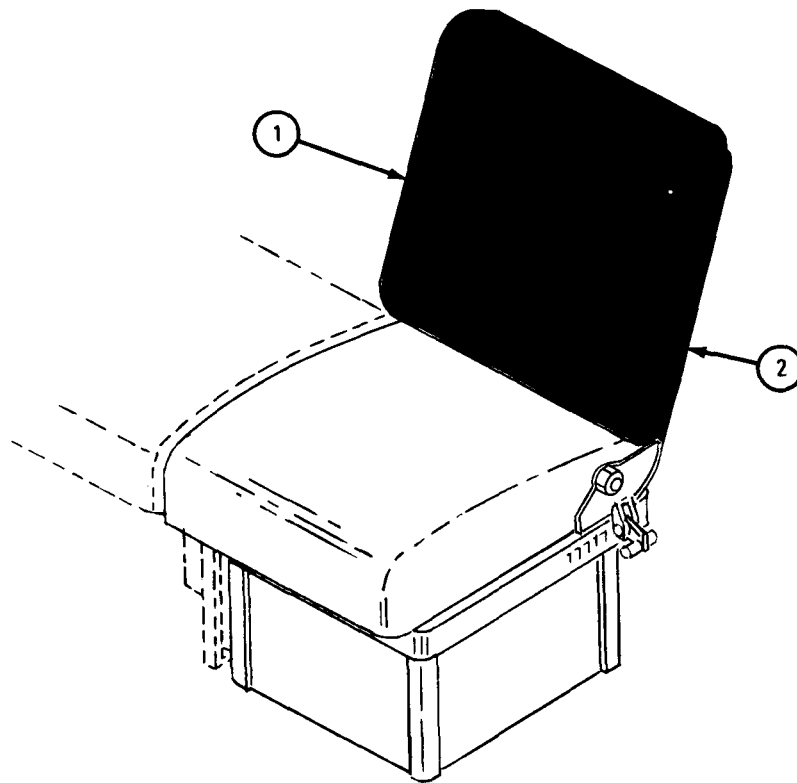
**END OF TASK**

TA 046221

18-11. COMPANION SEAT REMOVAL AND REPLACEMENT (LATER MODEL TRUCKS).

TOOLS: 9/16-inch wrench

SUPPLIES: None

PERSONNEL: One

EQUIPMENT CONDITION: Truck parked, engine off, handbrake set.

a. Removal.

FRAME 1

1. Working in cab of truck, tilt back companion seat cushion (1).

GO TO FRAME 2

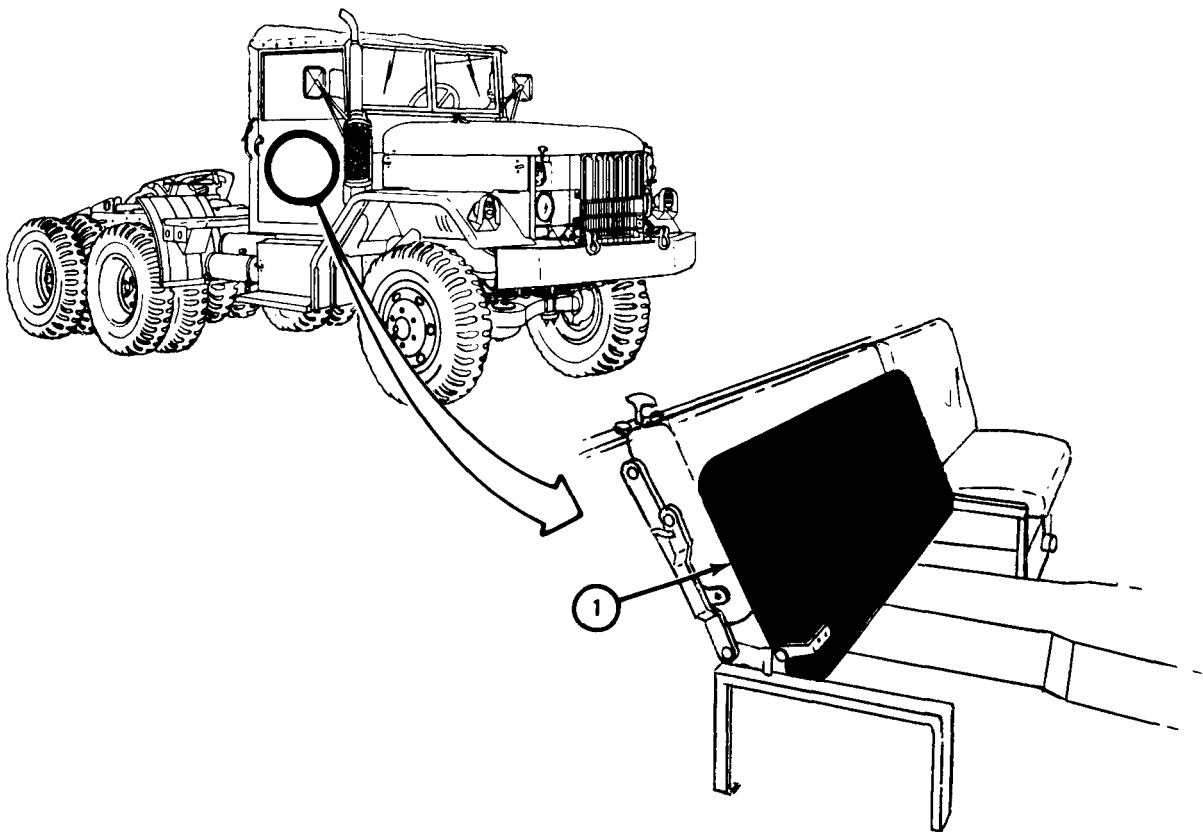

TA 046238

## FRAME 2

1. Using wrench, unscrew and take out four screws (1). Take off four lockwashers (2).
2. Take out companion seat (3).

END OF TASK

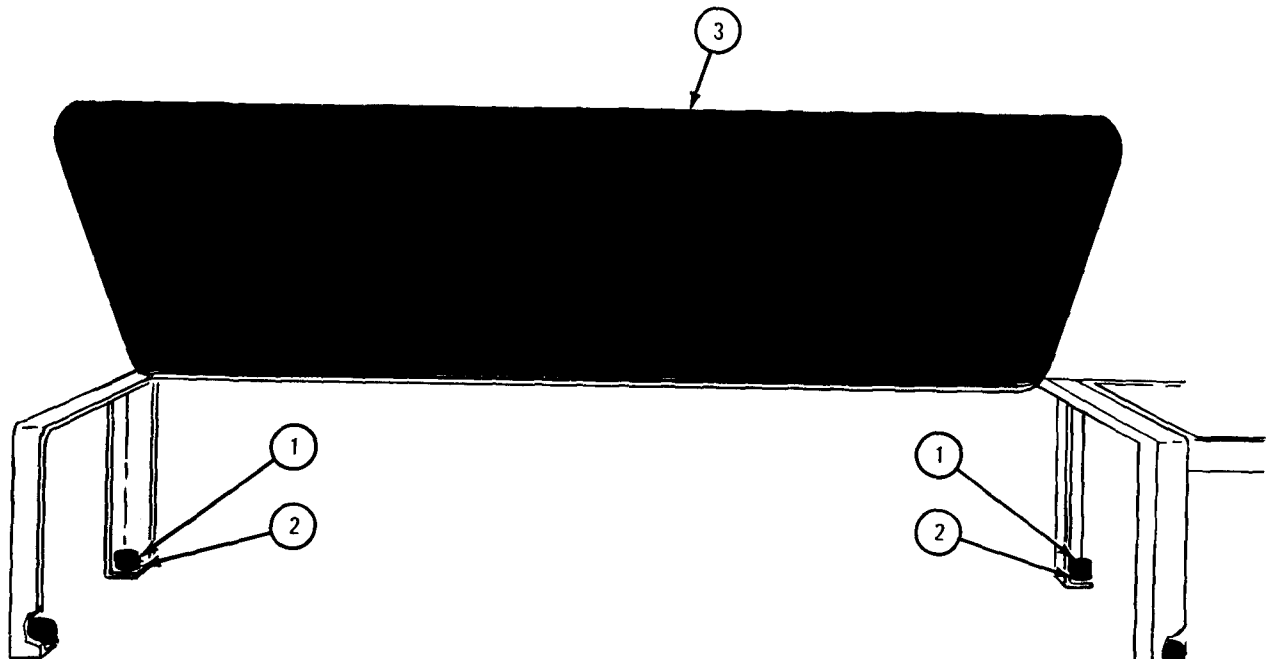

TA 046239

b. Replacement.

FRAME 1

1. Put companion seat (1) in place. Line up four holes in frame (2) with four mounting holes in floorboard.

GO TO FRAME 2

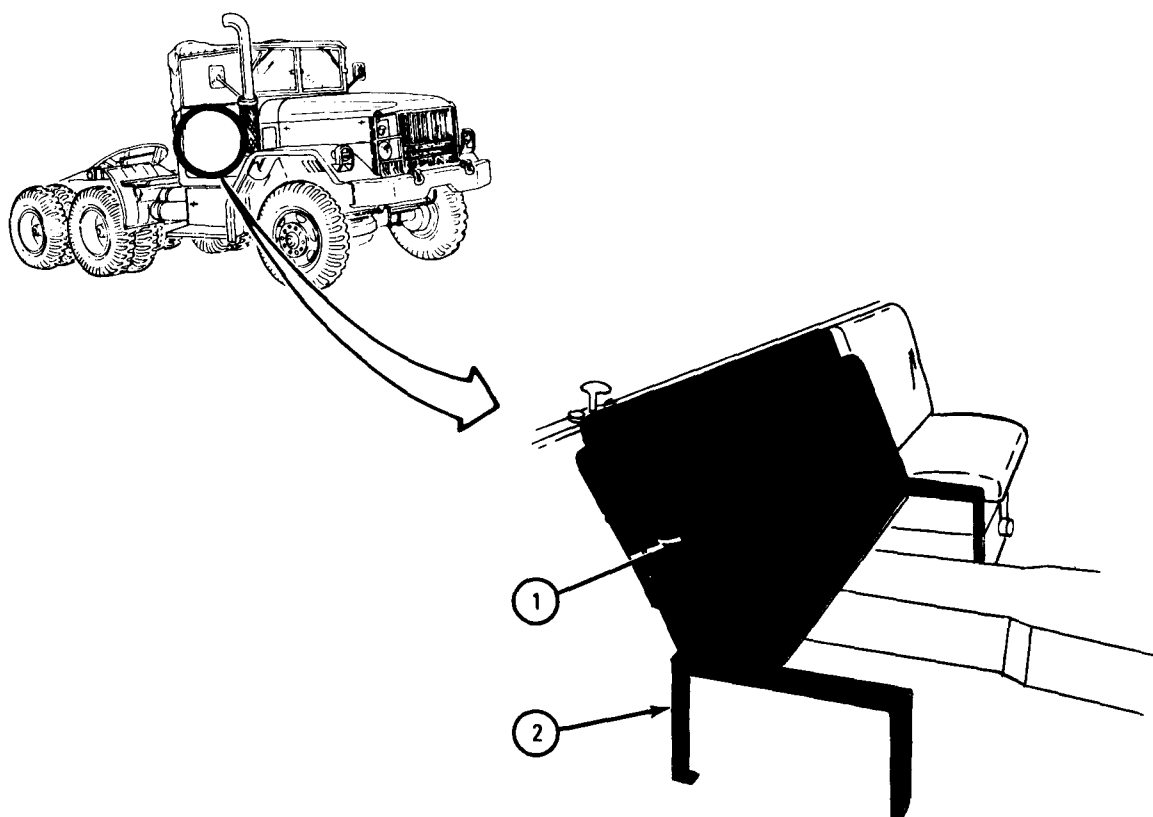

TA 046240



## FRAME 2

1. Put lockwashers (1) on four screws (2). Using wrench, screw in and tighten screws (2) through frame (3) and into floorboard.
2. Put companion seat cushion (4) down.

END OF TASK

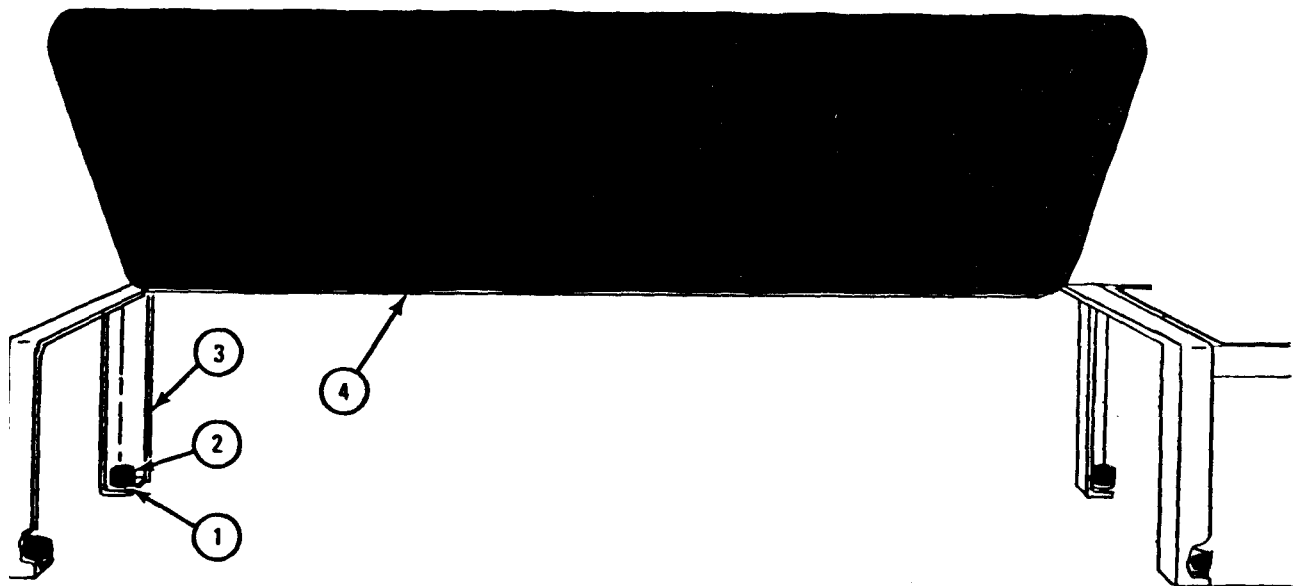

TA 046241

18-12. COMPANION SEAT REMOVAL AND REPLACEMENT (EARLY MODEL TRUCKS).

TOOLS: 9/16-inch wrench  
1/2-inch deep well socket wrench  
1/2-inch box wrench

SUPPLIES: None

PERSONNEL: One

EQUIPMENT CONDITION: Truck parked, engine off, handbrake set.

a. Removal.

FRAME 1

1. Working in cab of truck, tilt back companion seat cushion (1).

GO TO FRAME 2

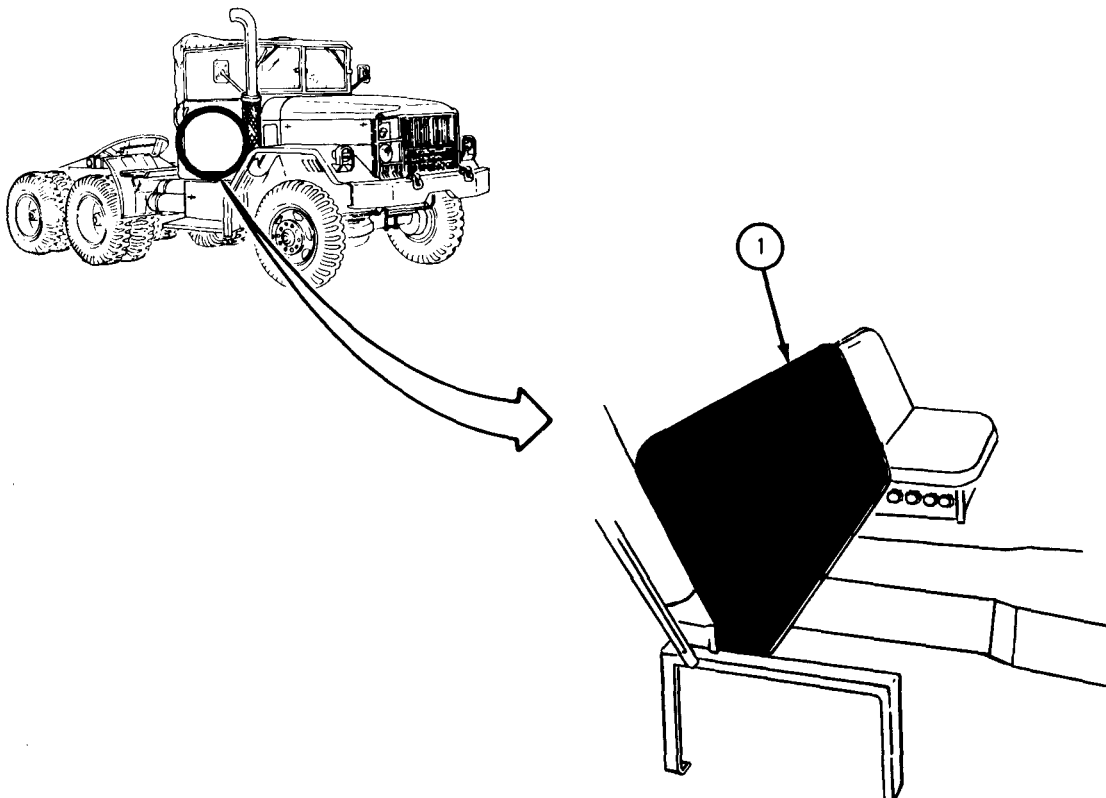

TA 046213

## FRAME 2

1. Using 9/16-inch wrench, unscrew and take out two screws (1). Take off lockwashers (2).
2. Using 1/2-inch box wrench and 1/2-inch socket wrench, unscrew and take off four nuts (3).
3. Lift and take out companion seat assembly (4).

END OF TASK

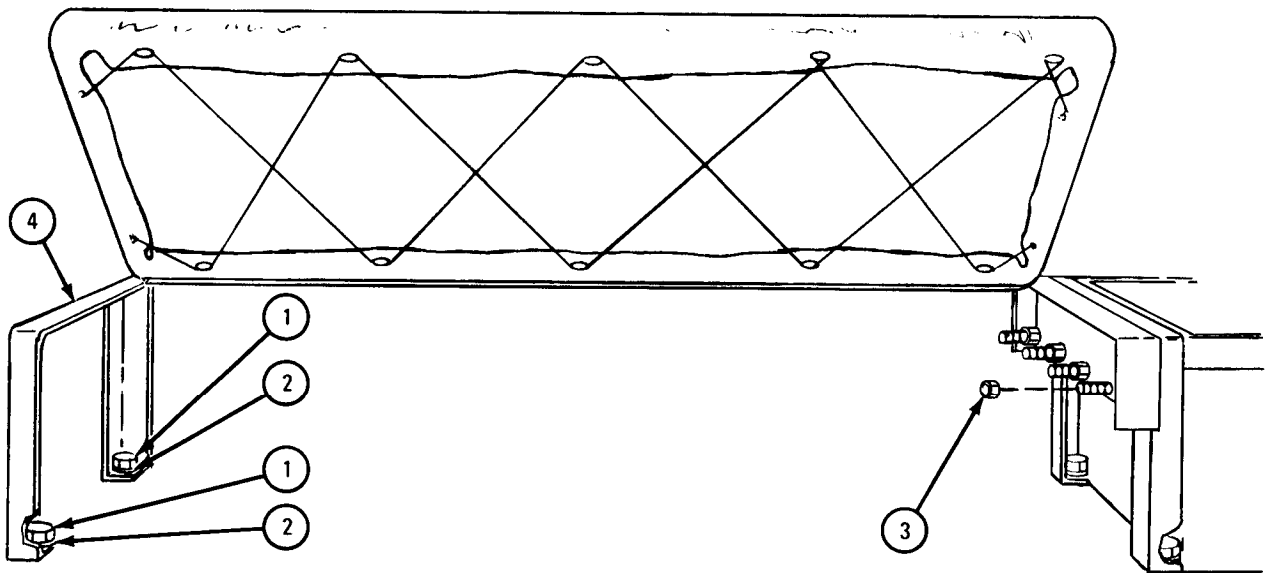

TA 046214

b. Replacement.

FRAME 1

1. Put companion seat assembly (1) in place.
  2. Tilt back companion seat cushion (2).
- GO TO FRAME 2

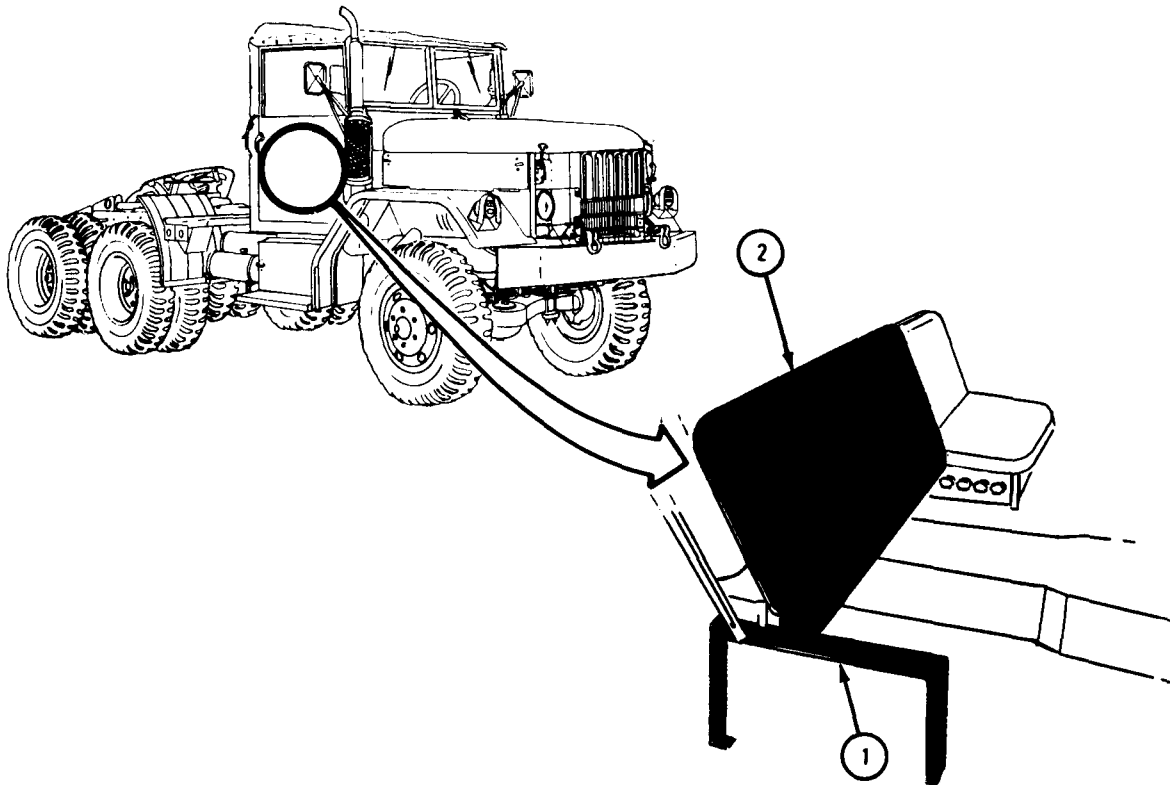

TA 046215

## FRAME 2

1. Lift up companion seat frame (1) on driver's side and put it against driver's seat base (2). Line up four mounting holes.
2. Put four screws (3) through companion seat frame (1). Start nuts (4).
3. Using 1/2-inch box wrench and 1/2-inch socket wrench, hold screws (3) and screw on and tighten nuts (4).
4. Put lockwashers (5) on two screws (6). Put screws (6) through holes in legs of companion seat frame (1). Using 9/16-inch wrench, tighten screws.
5. Put companion seat cushion (7) down.

END OF TASK

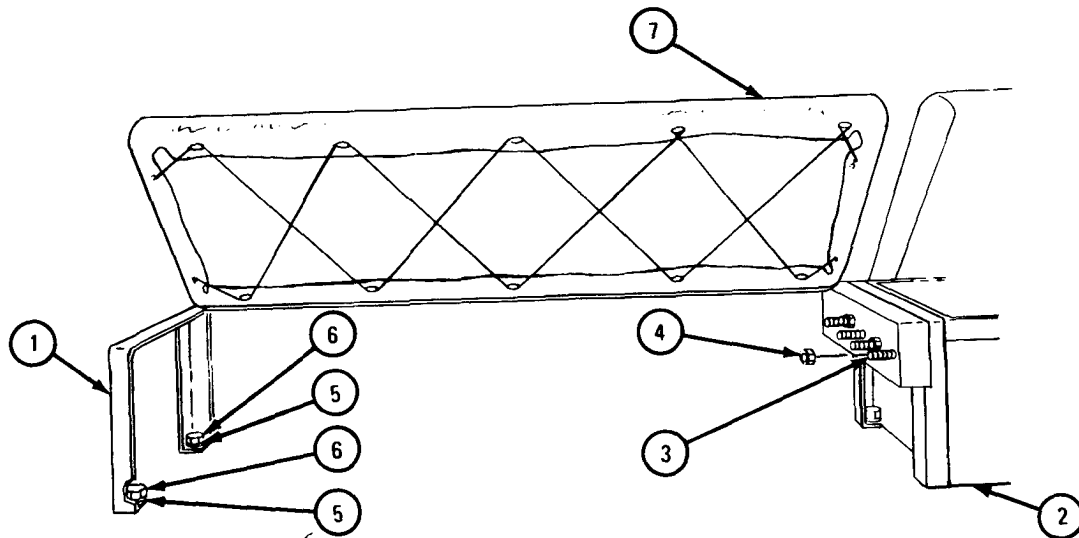

TA 046216

18-13. COMPANION SEAT REPAIR (EARLY MODEL TRUCKS).

TOOLS: Pliers  
1/2-inch wrench (2)

SUPPLIES: None

PERSONNEL: One

EQUIPMENT CONDITION: Truck parked, engine off, handbrake set.

NOTE

Repair of companion seat is limited to removal and replacement of seat cushion and backrest.

a. Removal.

FRAME 1

NOTE

All trucks except trucks M275A1 and M275A2 have same hinge pins on both sides of companion seat. Trucks M275A1 and M275A2 have clevis pins (1) with cotter pin (2) on right side of seat and clevis pin welded to frame on left side of seat.

Check hinge pin to see if it is a clevis pin or a bolt. If it is a clevis pin, go to step 1. If it is a bolt, go to frame 2.

1. Using pliers, pull out two cotter pins (2). Push out and take away two clevis pins (1).

GO TO FRAME 3

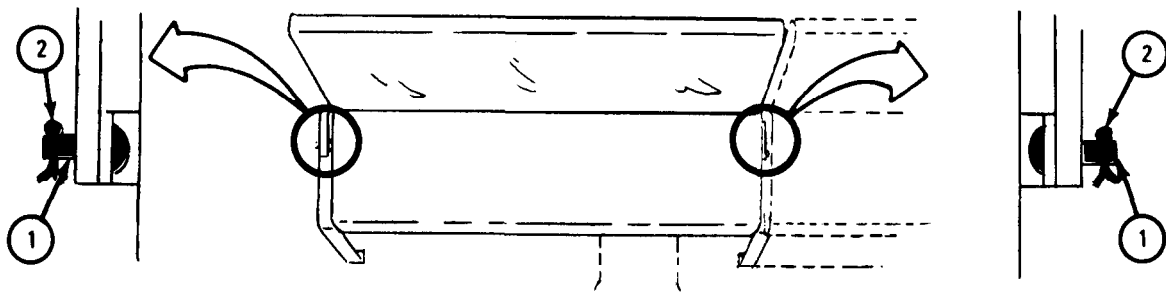
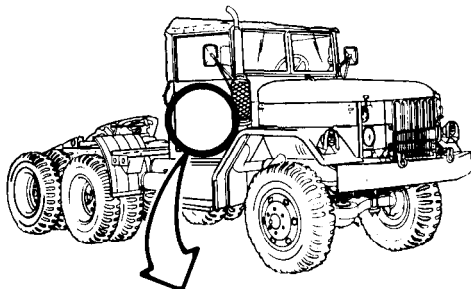

TA 046223

## FRAME 2

1. Using wrenches, unscrew and take out two screws (1) and nuts (2).

GO TO FRAME 3

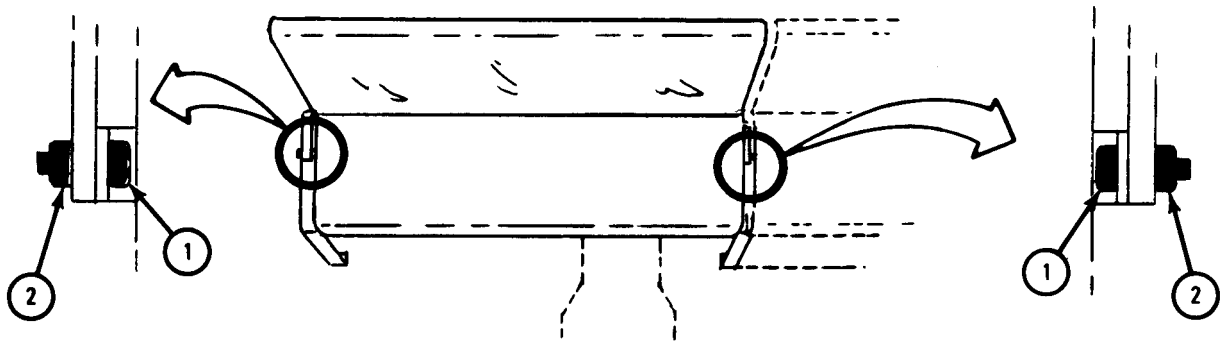

TA 046224

**FRAME 3**

1. Tilt companion seat cushion (1) back to the up position. Using wrenches, unscrew and take out screw (2) and nut (3).
2. Take off companion seat cushion (1) by lifting up and pulling it to right side of truck.

GO TO FRAME 4

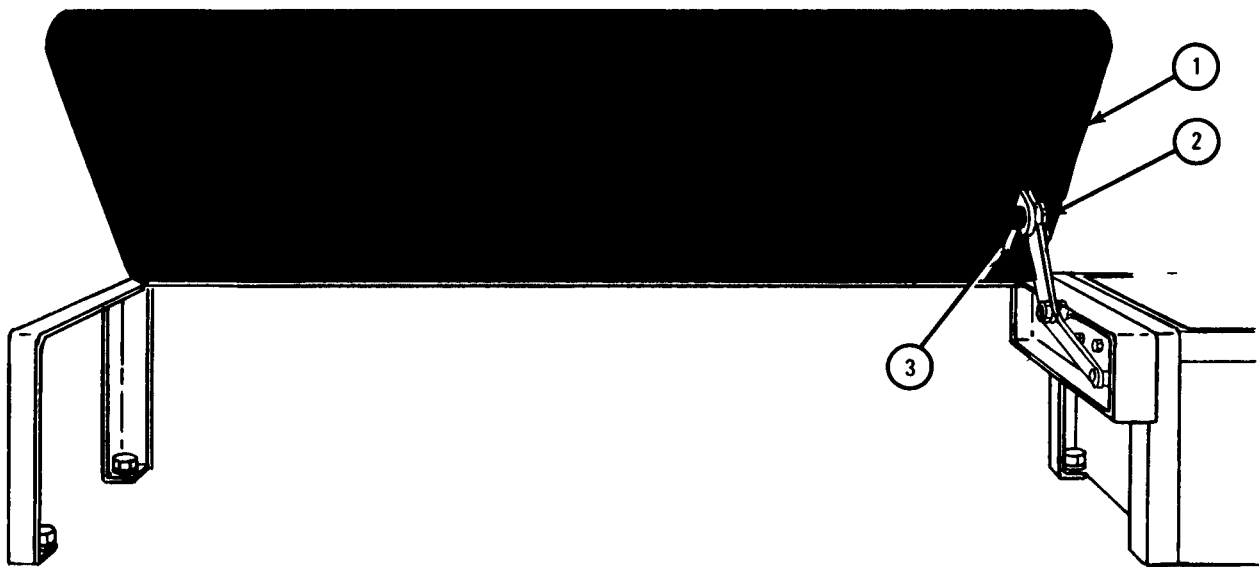

TA 046225



**FRAME 4**

1. Hold back rest (1) at bottom and lift up. Pull back rest bottom away from frame (2). Take off back rest.

END OF TASK



TA 046226

b. Replacement.

FRAME 1

1. Hold back rest (1) at bottom. Put top of back rest in top of frame (2). Lift up back rest and push into bottom of frame.

GO TO FRAME 2

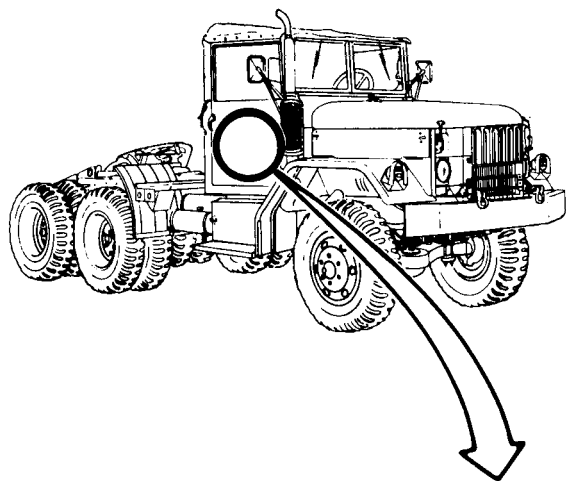

TA 046227

**FRAME 2**

1. Put companion seat cushion (1) in place in the tilted up position.
2. Put screw (2) through link (3) and seat cushion part (4).
3. Using wrench, hold screw (2). Using wrench, screw on nut (5).

**NOTE**

Check to see if you have clevis pins or bolts for putting in companion seat cushion.

IF YOU HAVE CLEVIS PINS, GO TO FRAME 3.

IF YOU HAVE BOLTS, GO TO FRAME 4

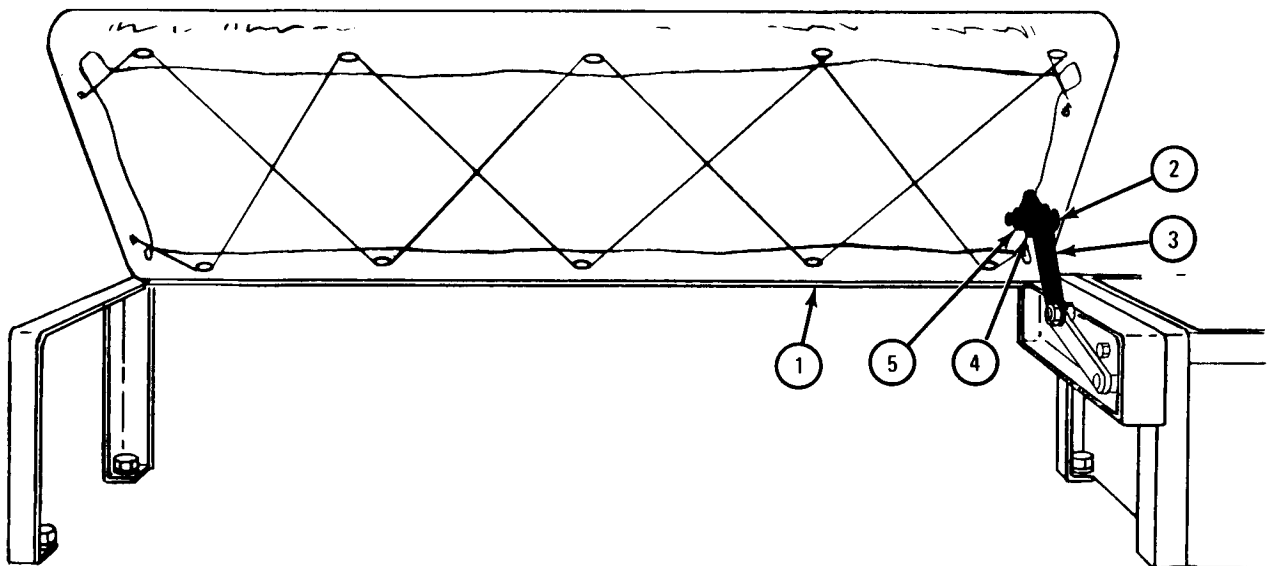

TA 046228

FRAME 3

1. Pull companion seat cushion (1) to the down position.
2. Put clevis pins (2) through brackets (3) and frame (4). Put cotter pins (5) in clevis pins. Using pliers, bend open ends of cotter pins.

END OF TASK

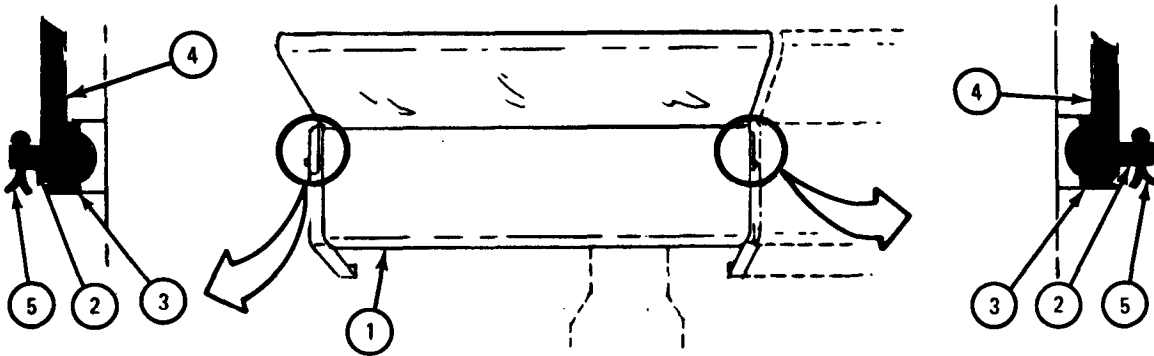

TA 046229

## FRAME 4

1. Pull companion seat cushion (1) to the down position.
2. Put screw (2) through bracket (3) and frame (4). Using wrench, hold screw. Using wrench, screw on nut (5).
3. Put screw (6) through bracket (7) and frame (4). Using wrench, hold screw. Using wrench, screw on nut (8).

END OF TASK

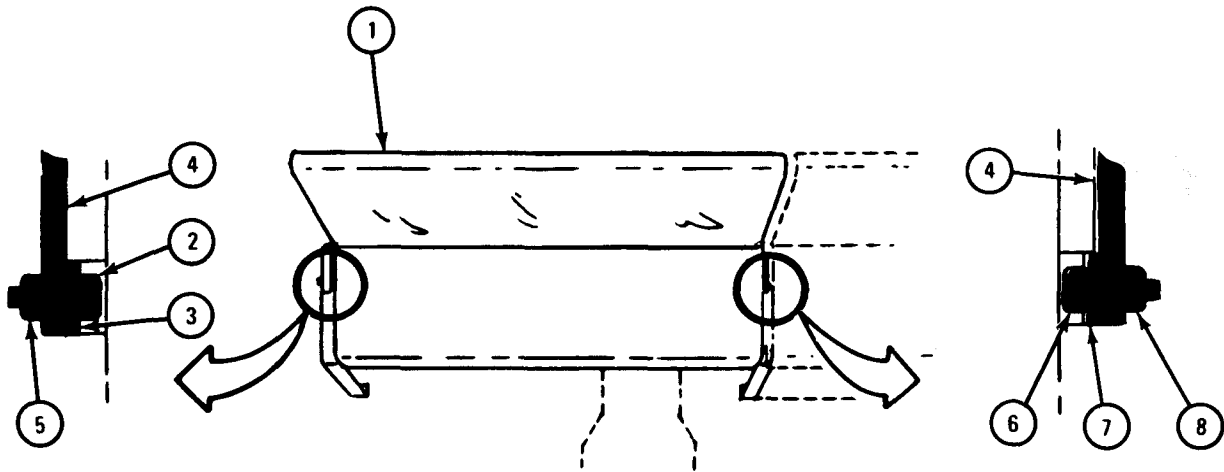

TA 046230

Section V. BRACKETS AND STRAPS

18-14. GASOLINE DRUM BRACKET REMOVAL AND REPLACEMENT.

TOOLS: 9/16-inch wrench (2)

SUPPLIES: None

PERSONNEL: One

EQUIPMENT CONDITION: Truck parked, engine off, handbrake set.

a. Removal.

FRAME 1

1. Using wrenches, hold four screws (1) and unscrew and take off four nuts (2). Take out screws.
2. Using wrench, hold two screws (3). Open tool box door (4).
3. Working inside tool box using wrench, unscrew and take off two nuts (5). Take out screws.
4. Take off bracket (6).

END OF TASK

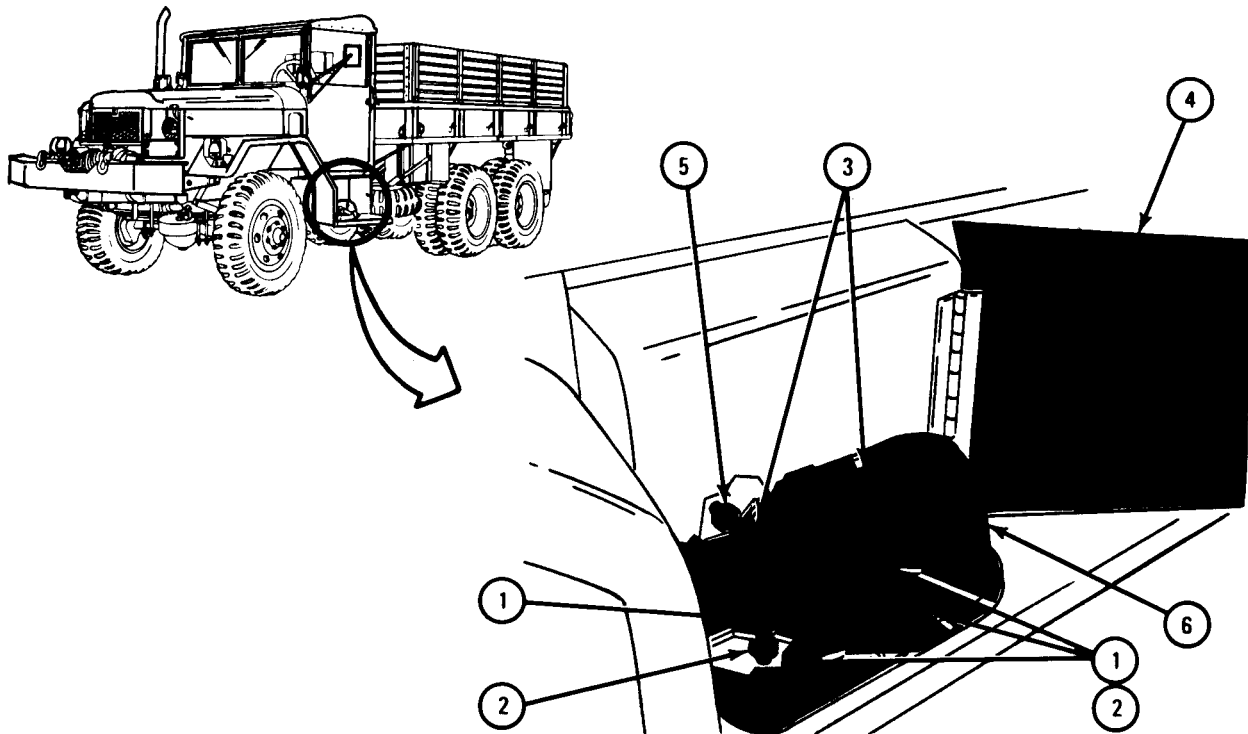

TA 046360

b. Replacement.

## FRAME 1

1. Put bracket (1) in place on running board (2). Put four screws (3) through bracket and running board. Start four nuts (4) on screws.
2. Open tool box door (5). Put two screws (6) through bracket (1) and tool box (7). Using wrench, hold screws.
3. Working inside tool box (7) using wrench, screw on and tighten two nuts (8). Close tool box door (5).
4. Using wrenches, hold four screws (3) and tighten four nuts (4).

END OF TASK

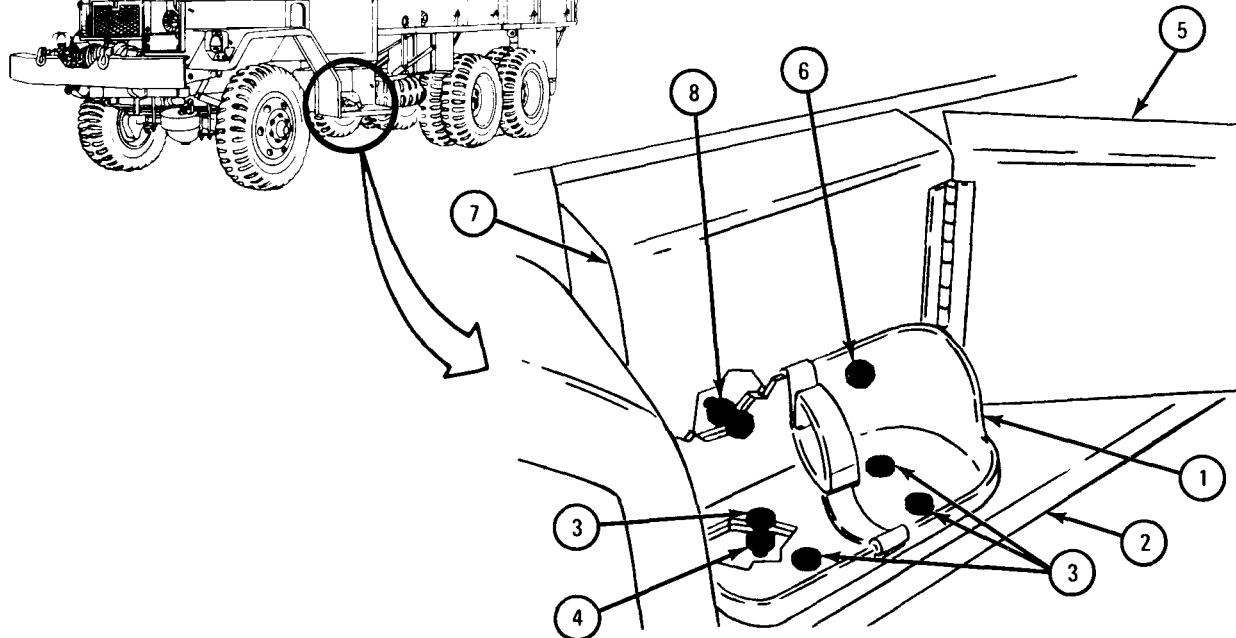

TA 046361

18-15. WEBBING STRAP REPAIR. Refer to FM 43-3 for detailed instructions for repair of webbing.

Section VI. CARGO BODY COMPONENTS

18-16. TAILGATE ASSEMBLY REMOVAL AND REPLACEMENT (ALL CARGO TRUCKS EXCEPT TRUCK M35A2C).

TOOLS: Hoist  
Lifting sling  
Pliers

SUPPLIES : None

PERSONNEL : One

EQUIPMENT CONDITION : Truck parked, engine off, handbrake set.

a. Removal

FRAME 1

1. Put lifting sling (1) through tailgate steps (2 and 3). Hook both ends of lifting sling to hook on hoist.
  2. Raise hoist until hoist holds weight of tailgate (4) but does not lift tailgate up.
- GO TO FRAME 2

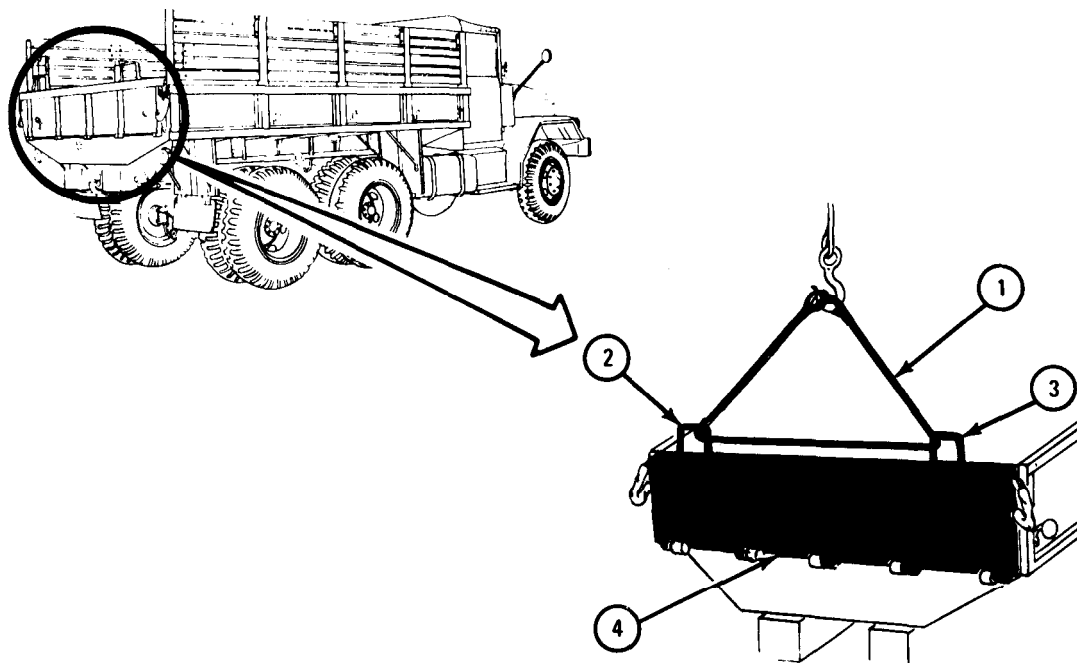



## FRAME 2

1. Take hooks (1) out of hole in post (2) on both sides of tailgate (3).
2. Using pliers, take out five cotter pins (4). Take out five pins (5) and ten washers (6).
3. Lower hoist until tailgate (3) is on ground and unhook lifting sling (7) from hoist hook. Take off lifting sling.

END OF TASK

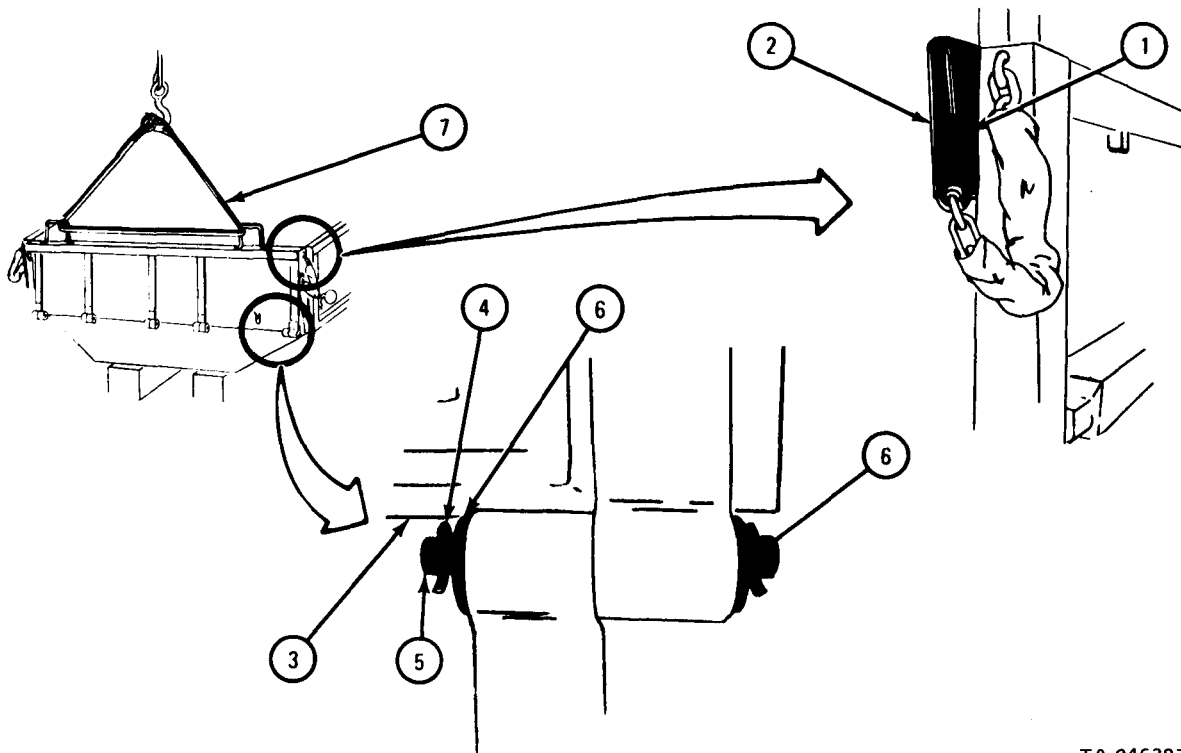

TA 046397

b. Replacement.

**FRAME 1**

1. Put lifting sling (1) through tailgate steps (2 and 3). Hook both ends of lifting sling to hook on hoist.
  2. Raise hoist to put tailgate (4) on truck as shown.
- GO TO FRAME 2

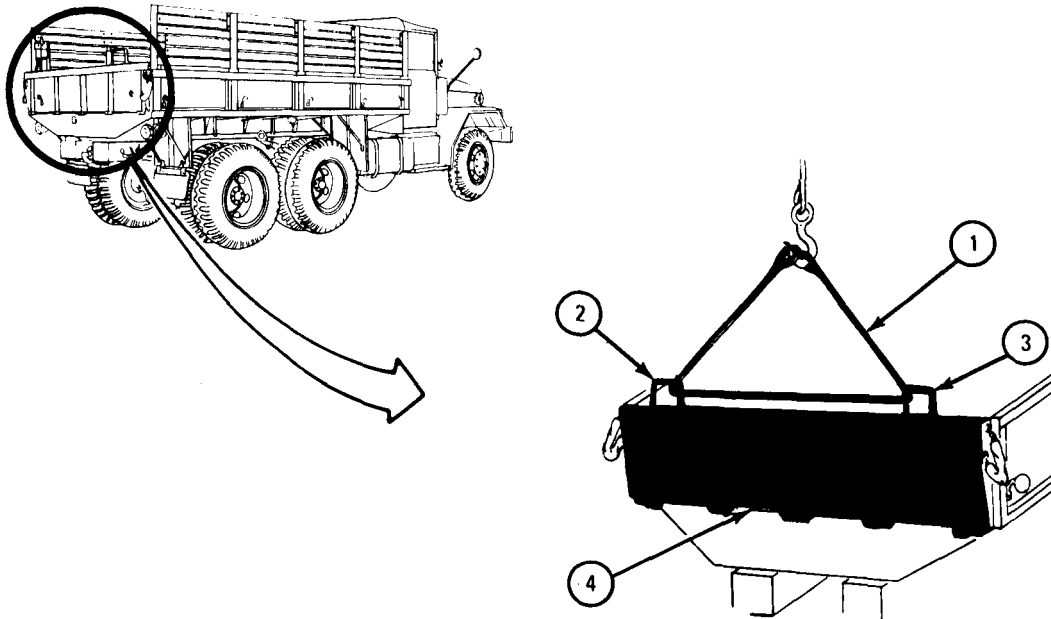

TA 046396

## FRAME 2

1. Put five washers (1) on five pins (2) and put pins through hinge parts (3). Put five washers on other end of pins.
2. Put five cotter pins (4) through holes in ends of five pins (2). Using pliers, bend open ends of cotter pins.
3. Put hooks (5) through posts (6) and into tailgate (7) on both sides of truck.
4. Lower hoist and unhook lifting sling (8) from hoist hook. Take off lifting sling and hoist.

END OF TASK

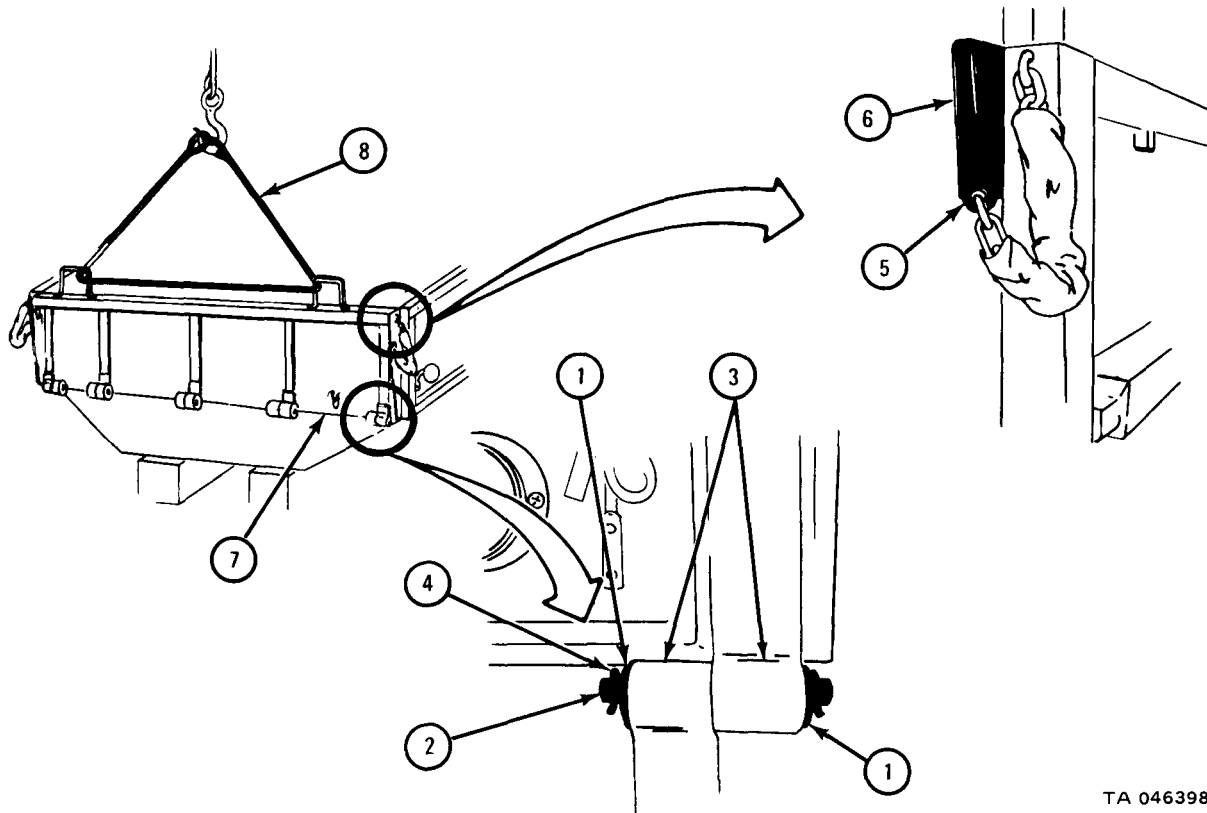

TA 046398

18-17. TAILGATE ASSEMBLY REMOVAL AND REPLACEMENT (TRUCK M35A2C).

TOOLS: Hoist  
Lifting sling  
Pliers

SUPPLIES: None

PERSONNEL: One

EQUIPMENT CONDITION: Truck parked, engine off, handbrake set.

a. Removal.

FRAME 1

1. Put lifting sling (1) through tailgate steps (2 and 3). Hook both ends of lifting sling to hook on hoist.
2. Raise hoist until hoist holds weight of tailgate (4) but does not lift tailgate up.

GO TO FRAME 2

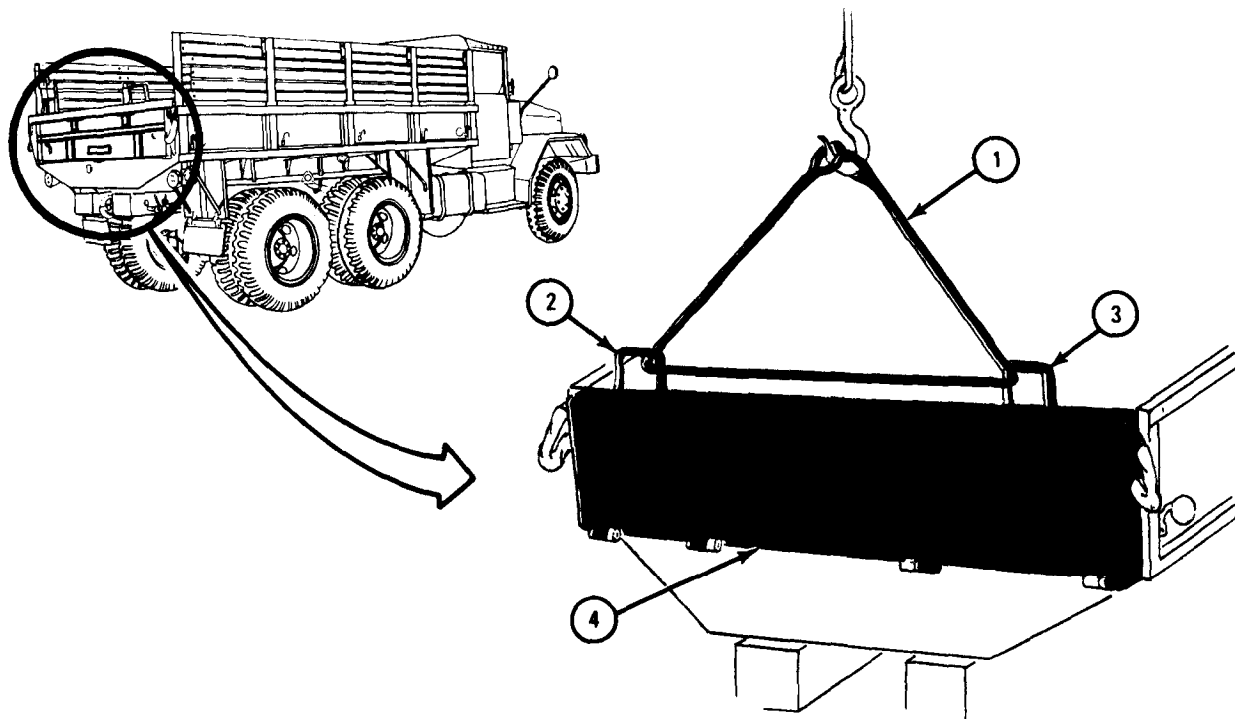

TA 046393

## FRAME 2

1. Unscrew handle (1) enough so bar (2) can be turned and taken out of slot (3).
2. Go to other side of tailgate (4) and do step 1 again.
3. Using pliers, take out four cotter pins (5). Take out four pins (6) and eight washers (7).
4. Lower hoist until tailgate (4) rests on ground and unhook lifting sling (8) from hoist hook. Take off lifting sling.

END OF TASK

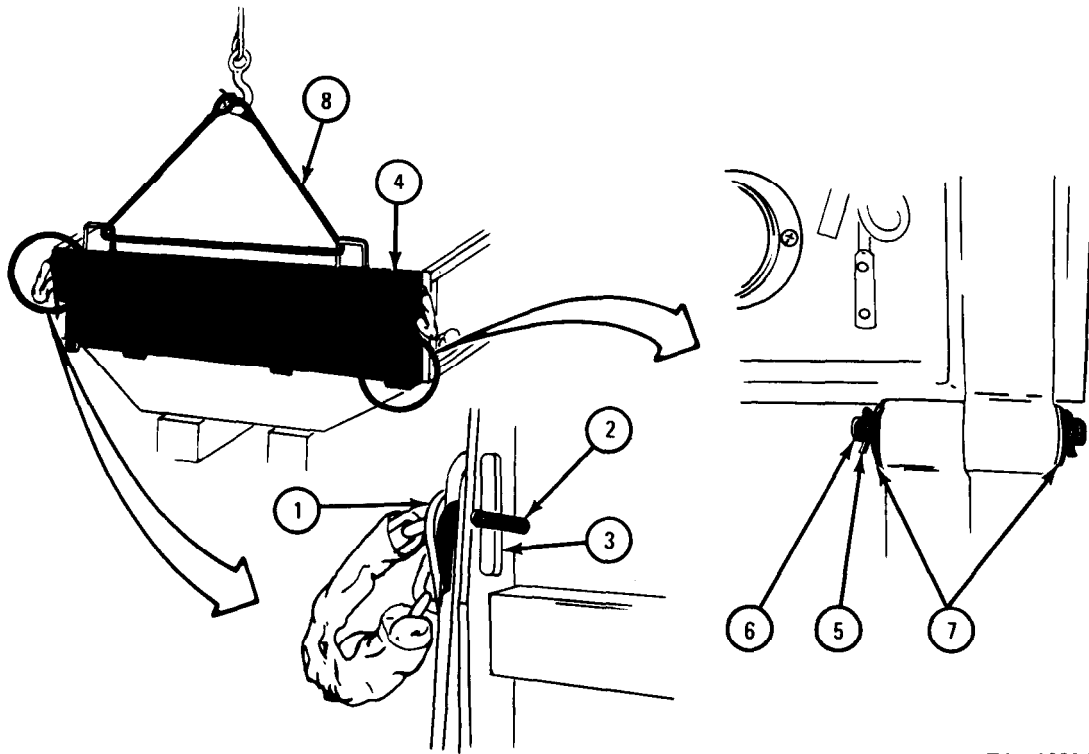

TA 046394

b. Replacement.

FRAME 1

1. Put lifting sling (1) through tailgate steps (2 and 3). Hook both ends of lifting sling to hook on hoist.
2. Raise hoist to put tailgate (4) on truck as shown.

GO TO FRAME 2

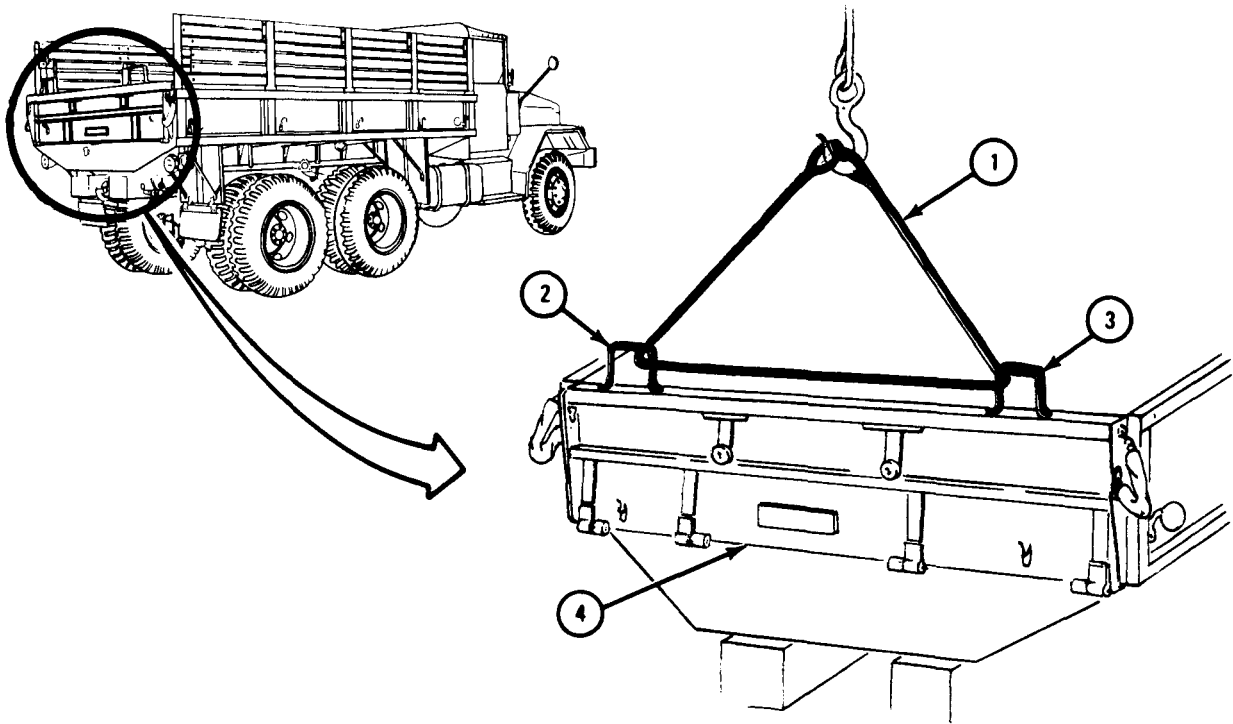

TA 046393

## FRAME 2

1. Put four washers (1) on four pins (2) and put pins through hinge parts (3). Put washers on other ends of pins.
2. Put cotter pins (4) through holes in ends of pins (2). Using pliers, bend open ends of cotter pins.
3. Put lock bar (5) through slot (6) and turn it crossways across slot. Screw on handle (7) to the right until it is tight.
4. Go to other side of tailgate (8) and do step 3 again.
5. Lower hoist and unhook lifting sling (9) from hoist hook. Take off lifting sling and hoist.

END OF TASK

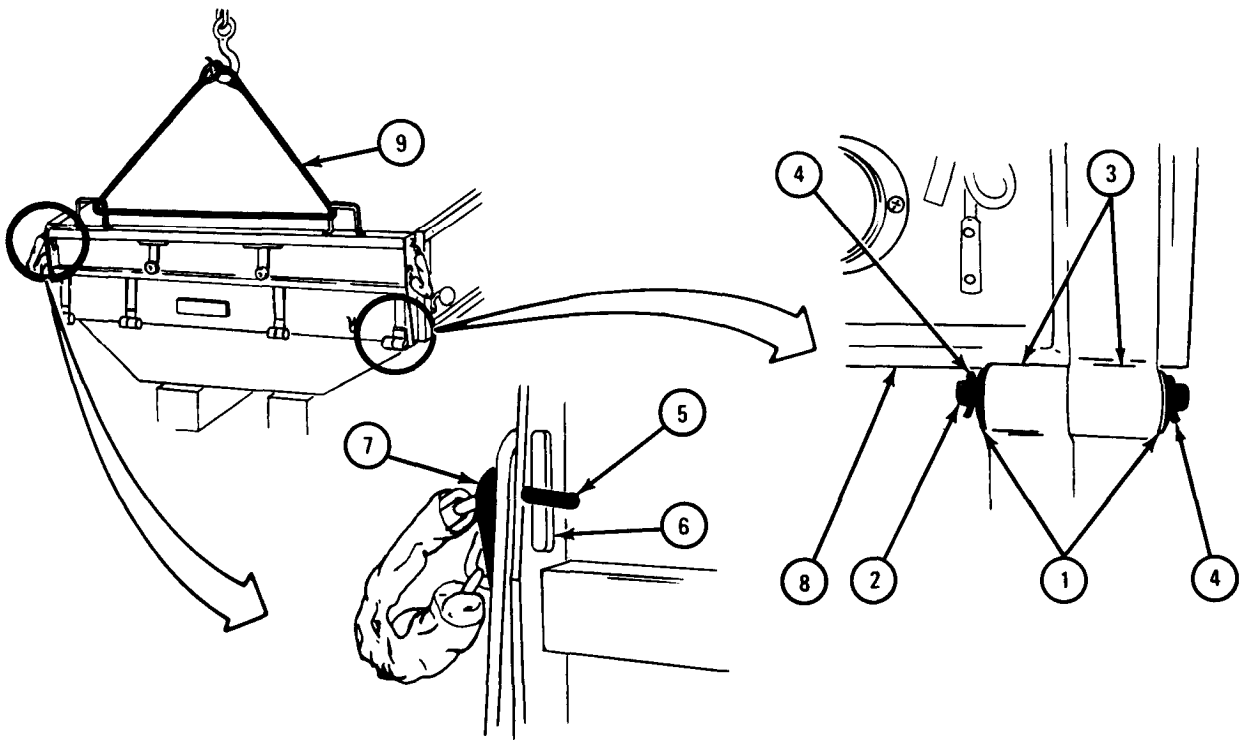

TA 046395

18-18. TROOP SEAT RACK ASSEMBLY REPAIR.

TOOLS: Pliers  
 Cross-tip screwdriver (Phillips type)  
 9/16-inch socket wrench  
 1/2-inch socket wrench  
 6-inch extension  
 Scrubbing brush  
 Mallet

SUPPLIES: Strong soap  
 Cold water  
 Rags  
 Solvent, dry cleaning, type II (SD-2), Fed. Spec P-D-680

PERSONNEL: One

EQUIPMENT CONDITION: Truck parked, engine off, handbrake set.

- a. Preliminary Procedure. Remove rack and seat assembly from truck. Refer to TM 9-2320-209-10.
- b. Disassembly of Rack and Seat Assembly.

FRAME 1

1. Lift up and hold leg (1) away from clevis pin (2).
2. Using pliers, take out five cotter pins (3), one on each leg (1).
3. Take out five clevis pins (2), one on each leg (1).
4. Take seat assembly (4) off of rack assembly (5).

END OF TASK

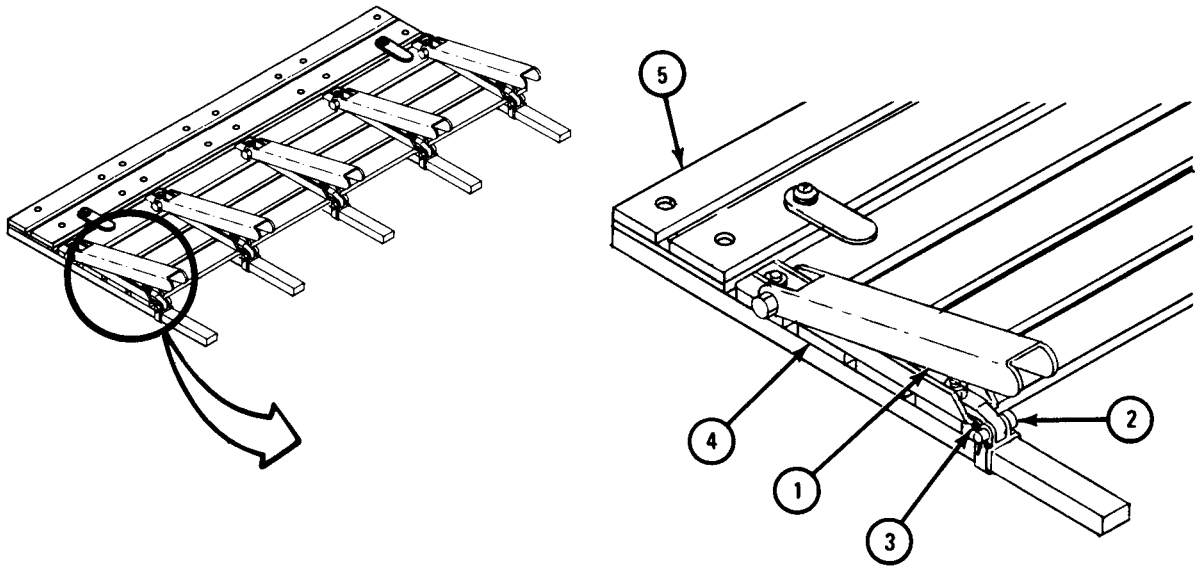

TA 046399



c. Disassembly of Rack Assembly.

## FRAME 1

1. Using phillips screwdriver and 1/2-inch wrench, unscrew and take out two screws (1). Take off two washers (2) and clamps (3).
2. Using 1/2-inch socket wrench with extension, unscrew and take off two nuts (4) from each end bow pocket assembly (5).
3. Using 1/2-inch socket wrench with extension, unscrew and take off four nuts (6) from each of three bow pocket assemblies (7).
4. Take off board (8) and board (9).
5. Using mallet, hammer eight square neck screws (10) out of board (8).
6. Using mallet, hammer eight square neck screws (10) out of board (9).

END OF TASK

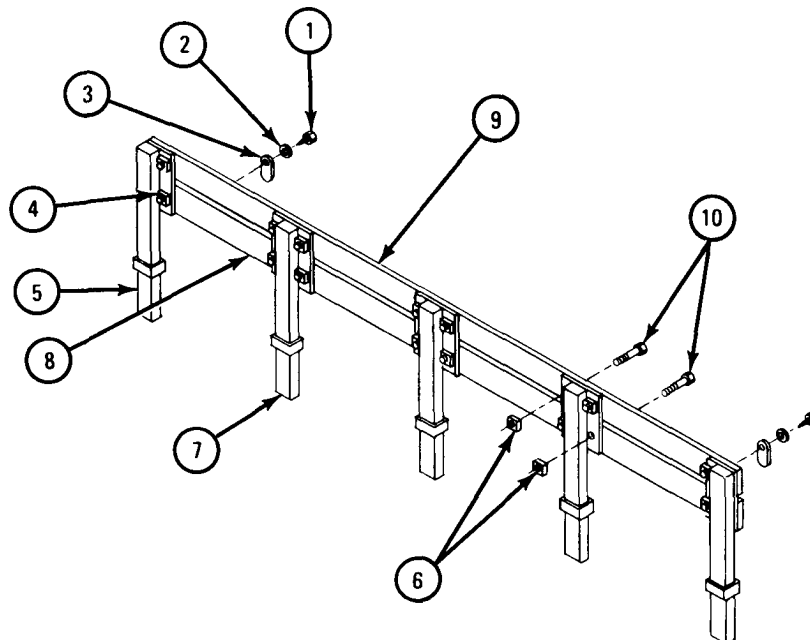

TA 046400

d. Disassembly of Seat Assembly.

FRAME 1

1. Using 9/16-inch socket wrench, hold machine screw (1) at each of five channels (2). Using 1/2-inch wrench, unscrew and take off five self locking nuts (3). Take away screws and five legs (4).

GO TO FRAME 2

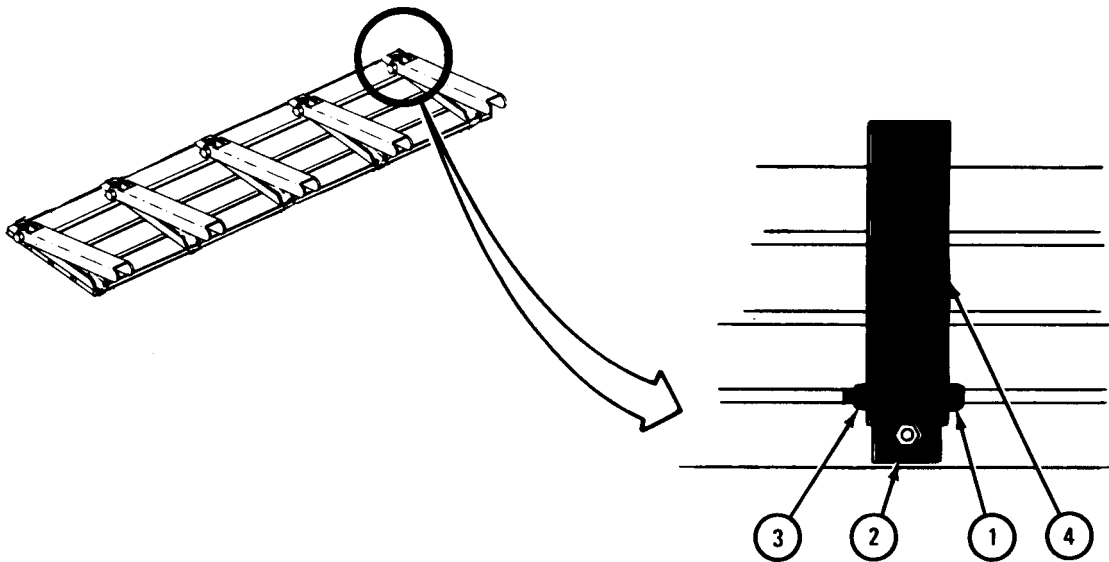

TA 101550

## FRAME 2

1. Using 1/2-inch socket wrench with extension, unscrew and take off four nuts (1) from each of five channels (2).
  2. Take off five hinges (3).
  3. Take off five channels (2).
  4. Using mallet, hammer five square neck screws (4) out of each outside board (5).
  5. Using mallet, hammer five square neck screws (6) out of each inside board (7).
- END OF TASK

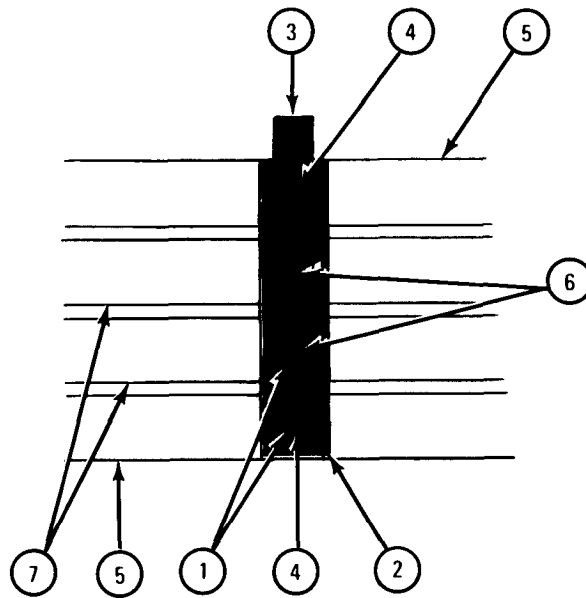
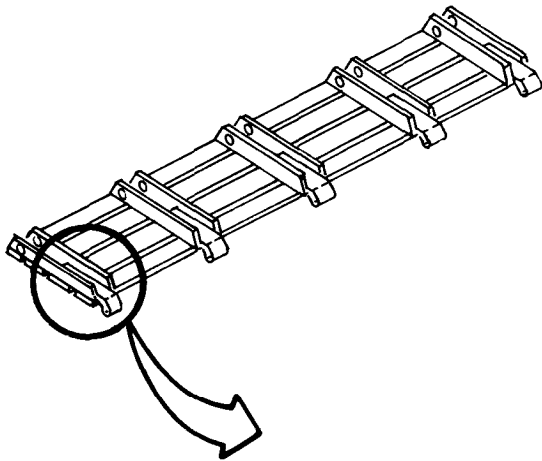

TA 046402

e. Cleaning.

WARNING

Dry cleaning solvent is flammable. Do not use near an open flame. Keep a fire extinguisher nearby when solvent is used. Use only in well-ventilated places. Failure to do this may result in injury to personnel and damage to equipment.

Eye shields must be worn when using compressed air. Eye injury can occur if eye shields are not used.

- (1) Using solvent, clean all metal parts. Dry with compressed air.
- (2) Using cold water, rinse all metal parts. Dry with compressed air.
- (3) Using strong soap and cold water, scrub all wood parts.
- (4) Using cold water, rinse all wood parts. Dry with compressed air.

f. Inspection and Repair.

(1) Look over all metal parts. Throw away any bent, broken or damaged parts. Get new parts in their place.

(2) Look over all wood parts. Throw away any cracked, splintered or warped parts. Get new parts in their place.

g. Assembly of Seat Assembly.

## FRAME 1

## NOTE

The top part of boards (1 and 6) have recesses around the screw holes to bury the screw head. The bottom part of boards do not have clearance around the screw holes.

1. Find top part of outside boards (1). Put five square neck screws (2) through holes in outside boards so screw heads are on top side. Put channels (3) onto screws with holes (4) to outside board.
2. Screw nuts (5) onto five square neck screws (2). If screws do not come through enough to start nut, use mallet and hammer screws in.
3. Find top part of outside board (6). Put five square neck screws (7) through holes in outside slat so screw heads are on top side. Put square neck screws through screw holes in channels (3).
4. Put hinges (8) onto five square neck screws (7) with bent part of hinge to top of outside slat (6).
5. Screw nuts (9) onto square neck screws (7). If screws do not come through enough to start nuts, use mallet and hammer screws in.

GO TO FRAME 2

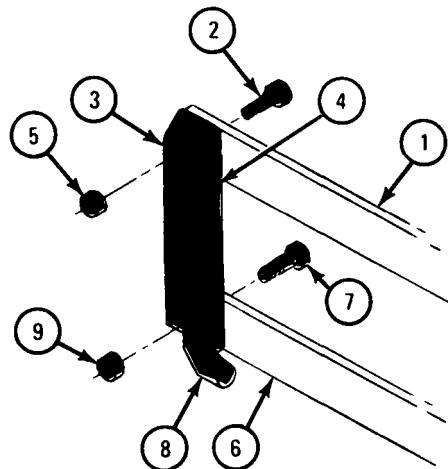

TA 046403

FRAME 2

NOTE

The top part of boards (1) have recesses around the screw holes to bury the screw head. The bottom part of boards do not have recesses around the screw holes.

1. Find top part of inside boards (1). Put five square neck screws (2) through holes in each inside board so screw heads are on top side.
2. Put square neck screws (2) through holes in channels (3). Screw nuts (4) onto square neck screws. If screws do not come through enough to start nuts, use mallet and hammer screws in.

GO TO FRAME 3

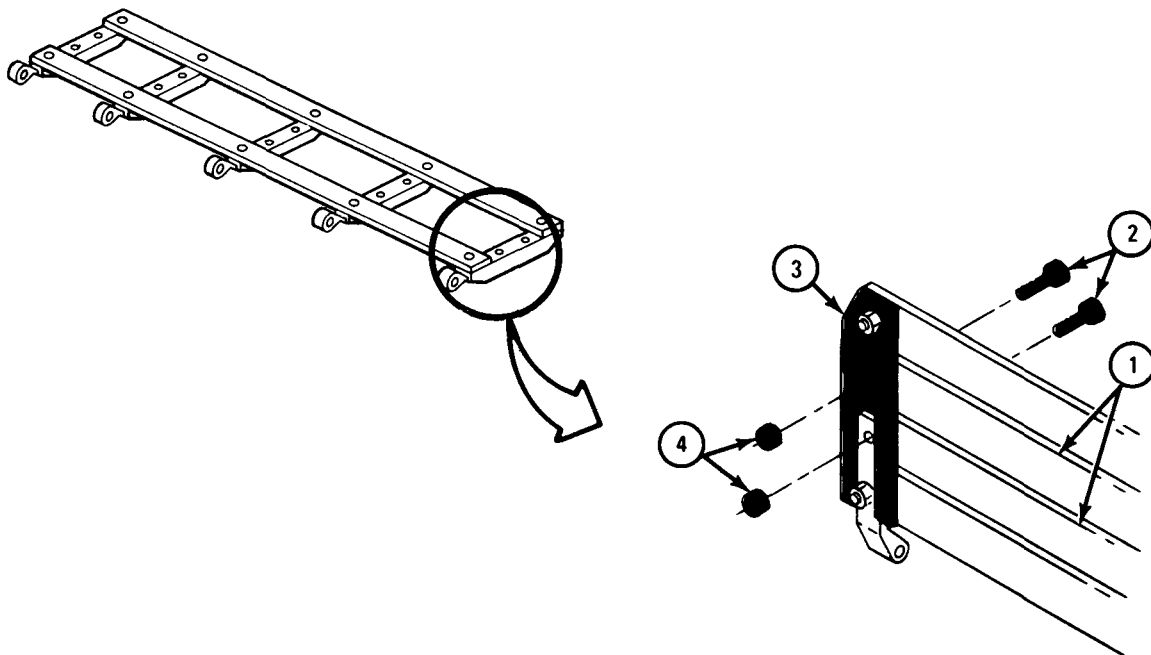

TA 046404

## FRAME 3

1. Put legs (1) onto five channels (2) lining up screw holes for machine screw (3). Put machine screw through holes in channels and legs and hold with 9/16-inch wrench.
2. Using 9/16-inch socket wrench, screw on self locking nuts (4) in five places. Screw them on until they are just snug and do not keep legs (1) from moving easily.

END OF TASK

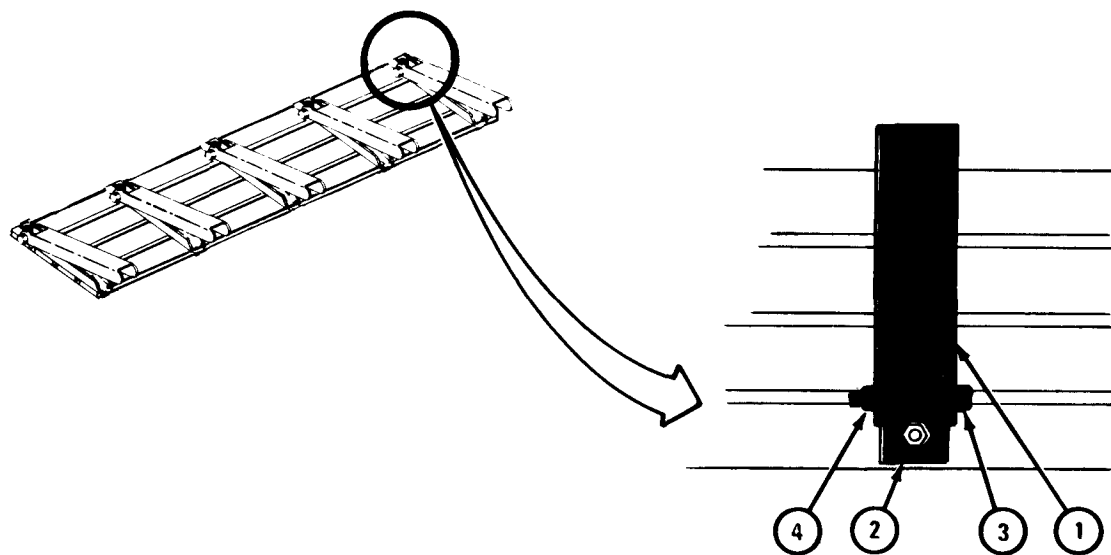

h. Assembly of Rack Assembly.

FRAME 1

NOTE

The front part of boards have recesses around the screw holes to bury the screw head. The back parts do not have recesses around the screw holes. Board (1) has eight holes.

1. Find front part of board (1). Put eight square neck screws (2) through eight holes in board so screw heads are on front side.
2. Put square neck screws (2) through end bow packet assemblies (3) and bow pocket assemblies (4). Using 1/2-inch wrench, start nuts (5) onto square neck screws. If screws do not come through enough to start nuts, use mallet and hammer screws in.
3. Find front part of board (6), which has 10 holes. Put eight square neck screws (7) through holes in board so screw heads are on front side.
4. Put square neck screws (7) through end bow pocket assemblies (3) and bow pocket assemblies (4). Using 1/2-inch wrench, start nuts (8) onto square neck screws. If screws do not come through enough to start nuts, use mallet and hammer screws in.

GO TO FRAME 2

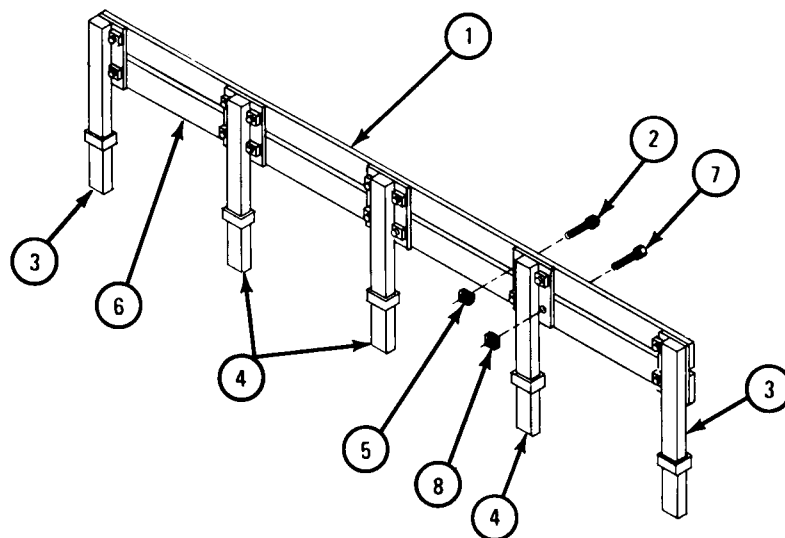

TA 046406



## FRAME 2

1. Put washer (1) onto wood screw (2). Put clamp (3) onto wood screw. Using phillips screwdriver and 1/2-inch wrench, screw wood screw into hole in board (4) until it is almost snug.
2. Go to other end of board (4) and do step 1 again for that end.

END OF TASK

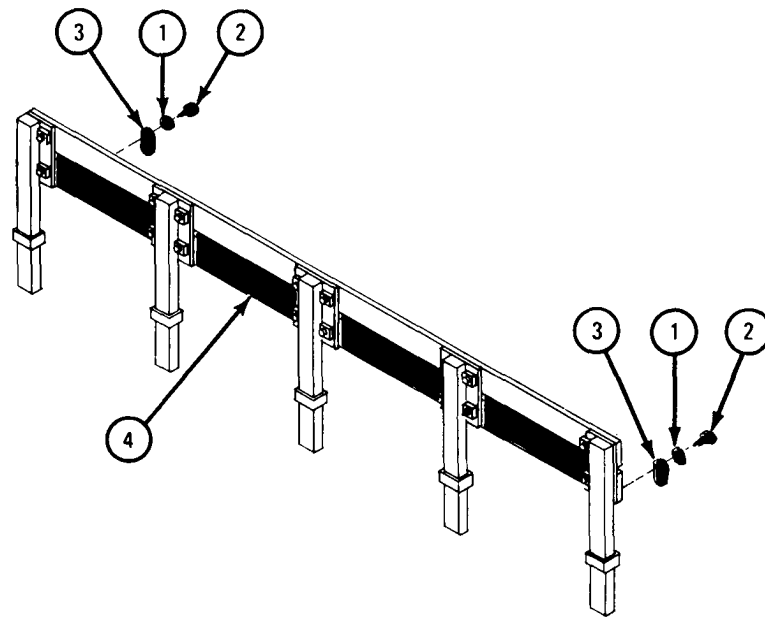

TA 046407

i. Assembly of Rack and Seat Assembly.

**FRAME 1**

1. Put seat assembly (1) into rack assembly (2) so that hinge parts (3) join together. Seat will be like it is folded up in truck.
2. Put clevis pin (4) through hinge parts (3) in five places. Put cotter pin (5) through hole in clevis pin. Using pliers, spread open ends of cotter pin.
3. Using 1/2-inch socket wrench with extension, tighten 20 nuts (6).
4. Using 1/2-inch wrench, tighten 16 nuts (7).

NOTE

Follow-on Maintenance Action Required:

Replace rack and seat assembly in truck. Refer to TM 9-2320-209-10.

END OF TASK

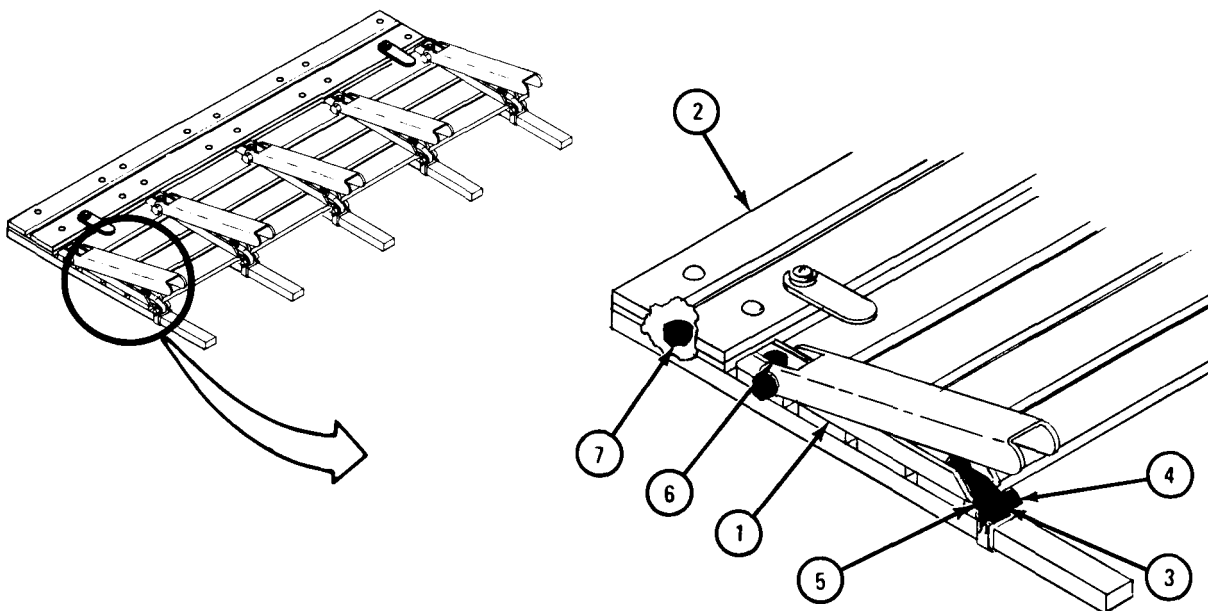

TA 046408

## Section VII. TANK BODY COMPONENTS

## 18-19. DISCHARGE VALVE ASSEMBLY REMOVAL AND REPLACEMENT (TRUCKS M49A1C AND M49A2C).

WARNING

Smoking, sparks or open flame is not allowed within 50 feet of fuel truck during this task. Fuel may burn, causing explosion, injury to personnel, and damage to equipment.

TOOLS: 3/4-inch wrench  
7/16-inch wrench  
7/8-inch wrench (2)  
Scraper  
Pliers

SUPPLIES: Discharge valve coupling gasket  
Discharge valve gasket

PERSONNEL: One

EQUIPMENT CONDITION: Truck parked, engine off, handbrake set, wheels chocked.

a. Preliminary Procedure. Drain tank of all fuel before removing discharge valve. Refer to TM 9-2320-209-10.

b. Removal.

**FRAME 1**

- Using 7/16-inch wrench, unscrew and take off two nuts (1). Take off plate (2) and U-bolt (3). Cable (4) will be free of valve lever (5).

GO TO FRAME 2

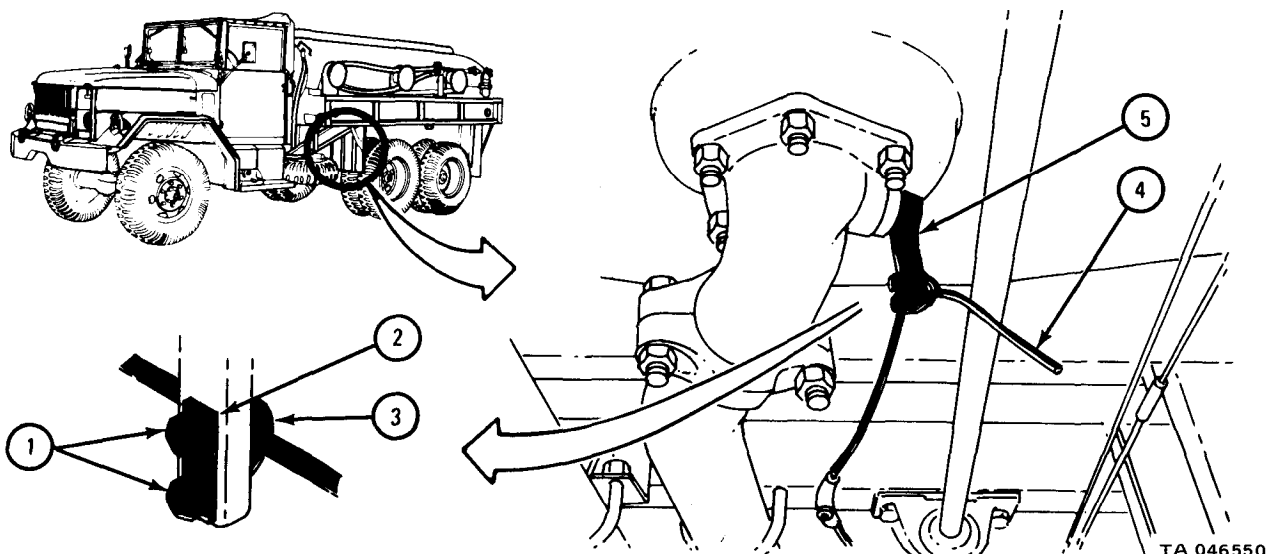

FRAME 2

1. Using 7/8-inch wrenches, unscrew and take out two screws (1) and nuts (2).
2. Take off lower coupling part (3). Take off upper coupling part (4).
3. Take off and throw away gasket (5).

GO TO FRAME 3

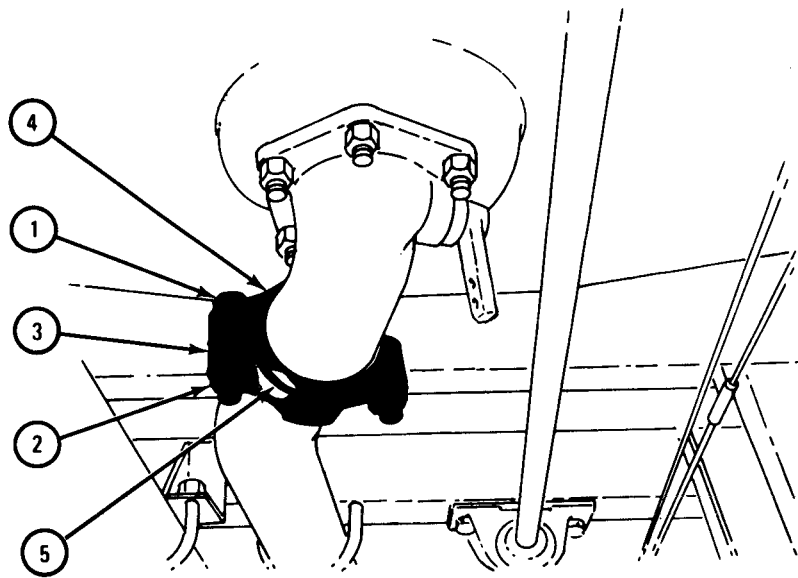

TA 046551

## FRAME 3

1. Using 3/4-inch wrench, unscrew and take off six nuts (1). Take off discharge valve (2). Take off and throw away gasket (3).
2. If needed, using scraper, take away any old gasket (3) material.
3. If needed, using scraper, take away any old gasket material around end of tube (4).

END OF TASK

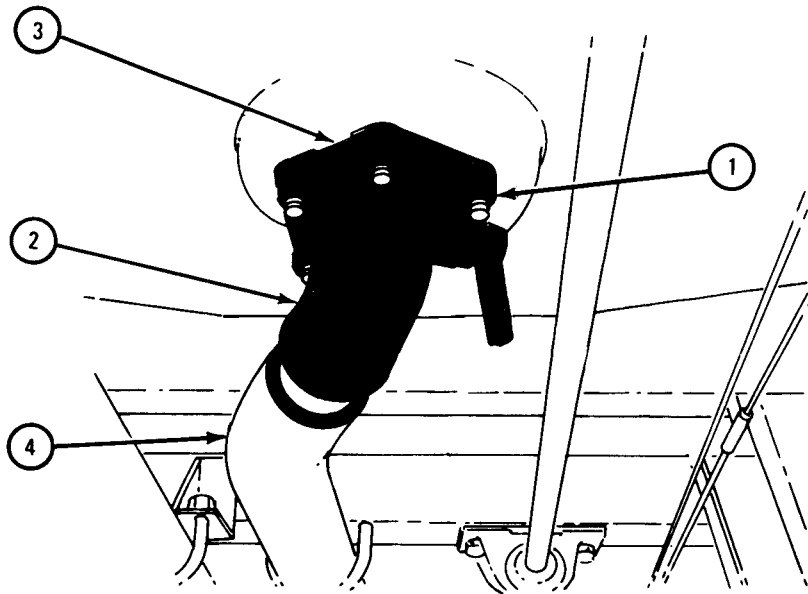

TA 046552

c. Replacement.

FRAME 1

1. Put gasket (1) in place on six screws (2).
2. Put gasket (3) on end of tube (4).
3. Put discharge valve (5) in place on six screws (2). Make sure it is pointing to tube (4). Using 3/4-inch wrench, screw on and tighten six nuts (6).

GO TO FRAME 2

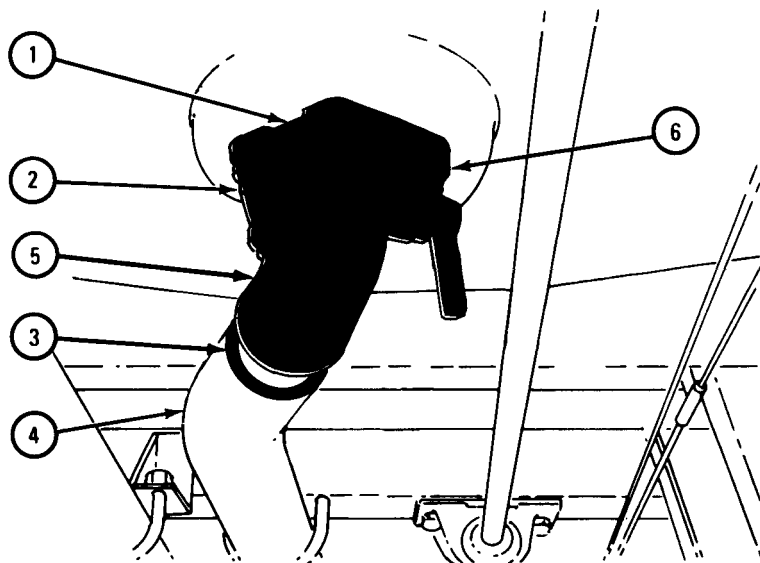
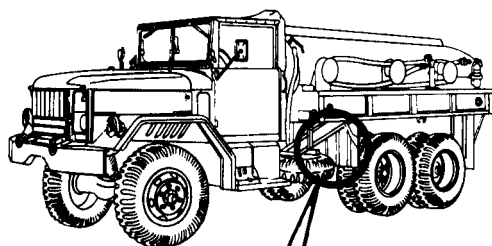

TA 046553

**FRAME 2**

1. Put upper coupling part (1) and lower coupling part (2) in place and line up screw holes. Put two screws (3) in place. Check that coupling will hold tube (4) to discharge valve (5).
2. Using 7/8-inch wrench, screw on and tighten two nuts (6).

GO TO FRAME 3

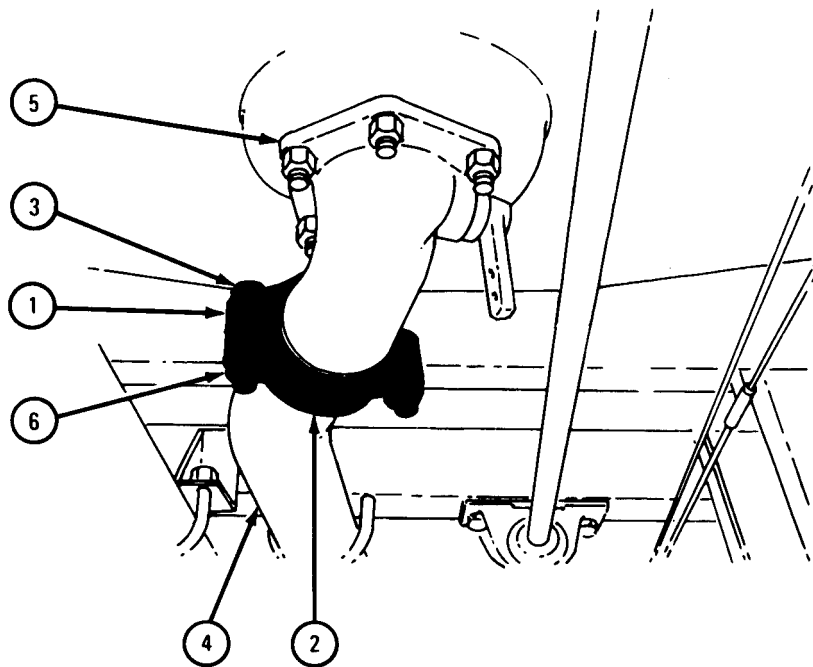

TA 046554

FRAME 3

1. Put cable (1) on valve lever (2) so it will be held by U-bolt (3). Put U-bolt through holes in valve lever.
2. Put plate (4) onto U-bolt (3). Start two nuts (5) onto U-bolt.
3. Using pliers, pull cable (1) through U-bolt (3) to take out most of the slack. While holding cable, using 7/16-inch wrench, tighten two nuts (5).

END OF TASK

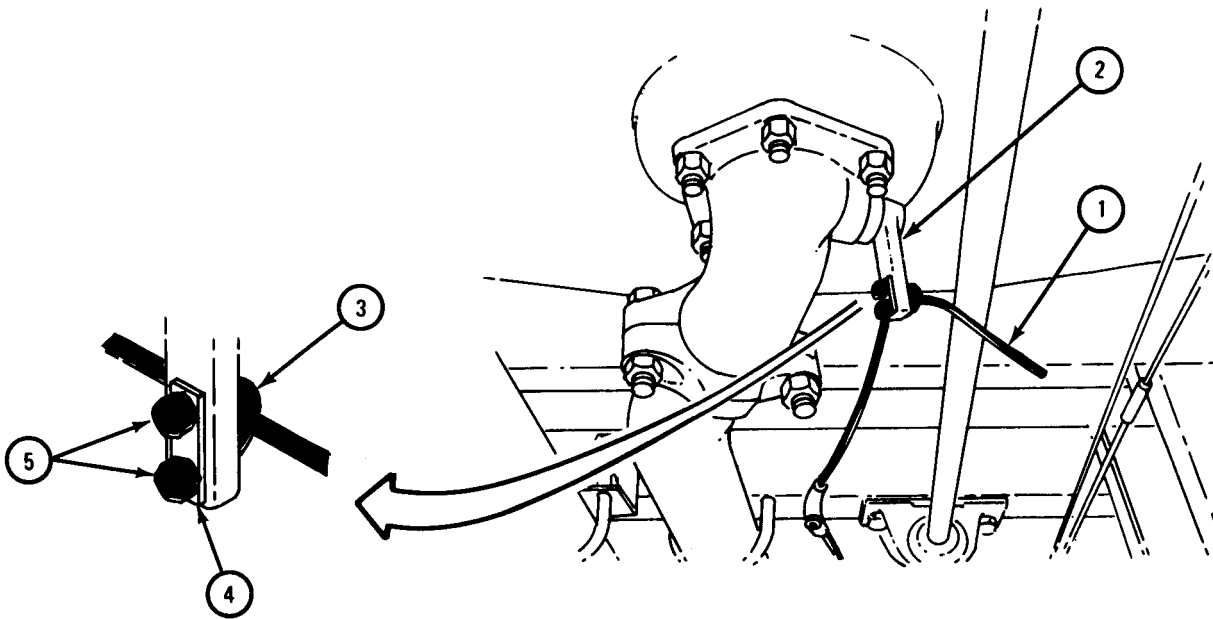

TA 046555



18-20. DISCHARGE VALVE PACKING REMOVAL AND REPLACEMENT (TRUCKS M49A1C AND M49A2C).

WARNING

Smoking, sparks or open flame is not allowed within 50 feet of fuel truck during this task. Fuel may burn, causing explosion, injury to personnel, and damage to equipment.

TOOLS: Pliers  
1 1/4-inch wrench  
Pick

SUPPLIES: Discharge valve preformed packing

PERSONNEL: One

EQUIPMENT CONDITION: Truck parked, engine off, handbrake set.

a. Removal.

**FRAME 1**

1. Using pliers, take out and throw away cotter pin (1).
2. Slide lever (2) off stem (3).

GO TO FRAME 2

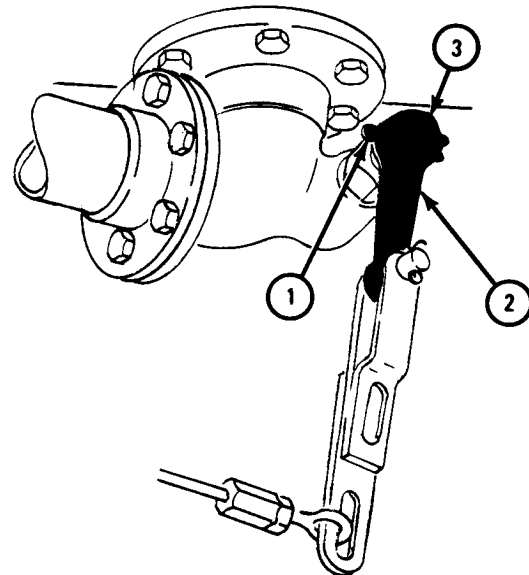
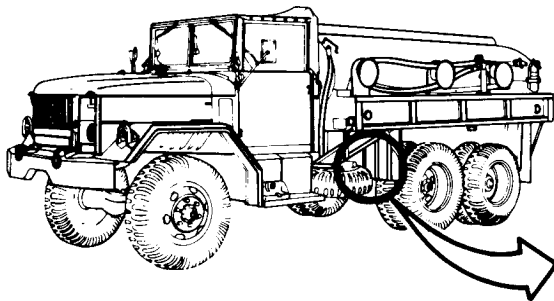

TA 046428

**FRAME 2**

1. Using wrench, unscrew and take off stem packing plug (1).
2. Using pick, take stem packing (2) out of valve body (3). Throw away stem packing.

END OF TASK

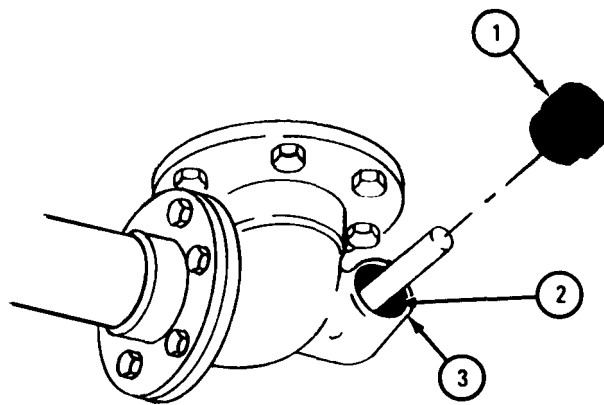

TA 101556

b. Replacement.

## FRAME 1

1. Put stem packing (1) on fuel tank discharge valve stem (2).
2. Put packing plug (3) on stem (2). Using packing plug as tool, push stem packing (1) into valve body (4).
3. Using wrench, screw in packing plug (3).

GO TO FRAME 2

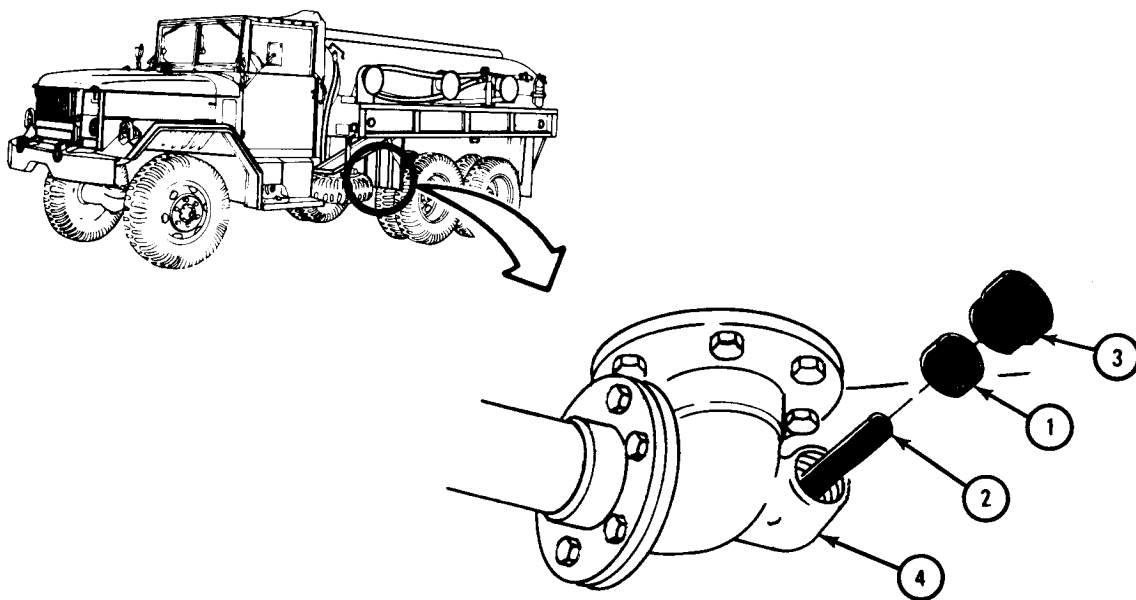

TA 046430

**FRAME 2**

1. Put lever (1) onto stem (2). Line up holes for cotter pin (3).
2. Put cotter pin (3) through holes in lever (1) and stem (2). Using pliers, bend open ends of cotter pin.

END OF TASK

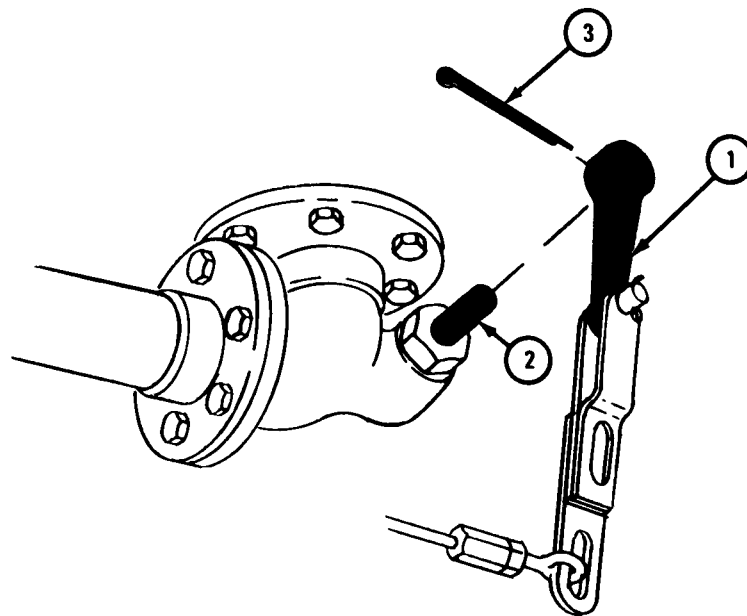

TA 101557

18-21. DISCHARGE PIPES REMOVAL AND REPLACEMENT (TRUCKS M49A1C AND M49A2C).

TOOLS: 9/16-inch open end wrench  
5/8-inch open end wrench  
9/16-inch socket  
7/8-inch open end wrench  
7/8-inch socket  
3/4-inch open end wrench  
Universal joint  
10-inch extension  
Ratchet

SUPPLIES: Discharge valve gasket (3)

PERSONNEL: Two

EQUIPMENT CONDITION: Truck parked, engine off, handbrake set.

a. Preliminary Procedure. Drain all fuel from holding compartments. Refer to TM 9-2320-209-10.

WARNING

Smoking, sparks or open flame are not allowed within 50 feet of fuel truck during this task. Fuel may burn, causing explosion, injury to personnel, and damage to equipment.

b. Removal.

(1) Truck M49A1C.

**FRAME 1**

- |                     |  |
|---------------------|--|
| Soldiers<br>A and B | 1. Open pump compartment doors.  |
| Soldier A           | 2. Using 5/8-inch open end wrench, unscrew and take off two nuts (1).  |
|                     | 3. Take out two bolts (2).   |
| Soldier B           | 4. Take off two halves of clamp (3).                                   |
|                     | 5. Slide gasket (4) toward rear of truck.                              |
| Soldiers<br>A and B | 6. Do steps 2 through 5 again for other two discharge pipe clamps (3). |

GO TO FRAME 2

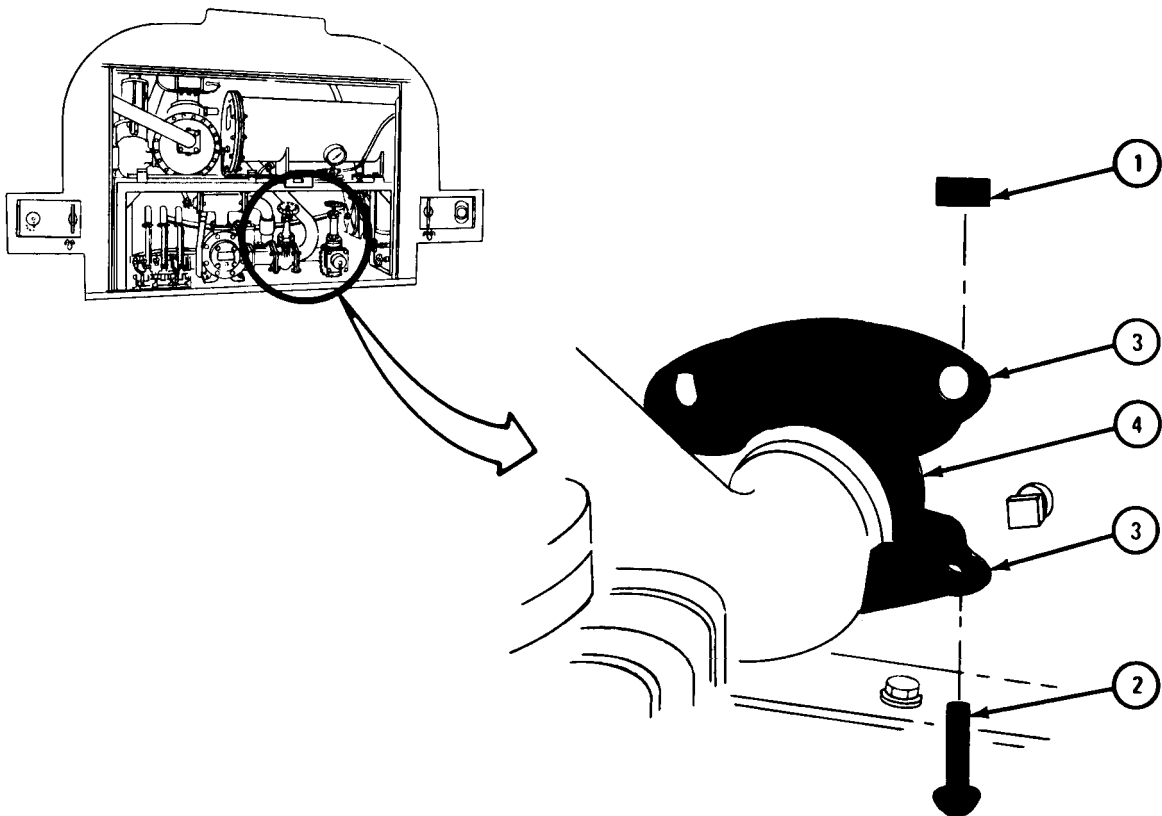

TA 104726

## FRAME 2

- Soldier A 1. Using 9/16-inch open end wrench, hold six screws (1).
- Soldier B 2. Using 9/16-inch socket wrench, universal, extension, and ratchet, unscrew and take off six nuts (2).
- Soldier A 3. Take out six screws (1).
- Soldier B 4. Take out and throw away gasket (3).
- Soldiers 5. Do steps 1 through 4 again on other two discharge valves (4).
- A and B
- GO TO FRAME 3

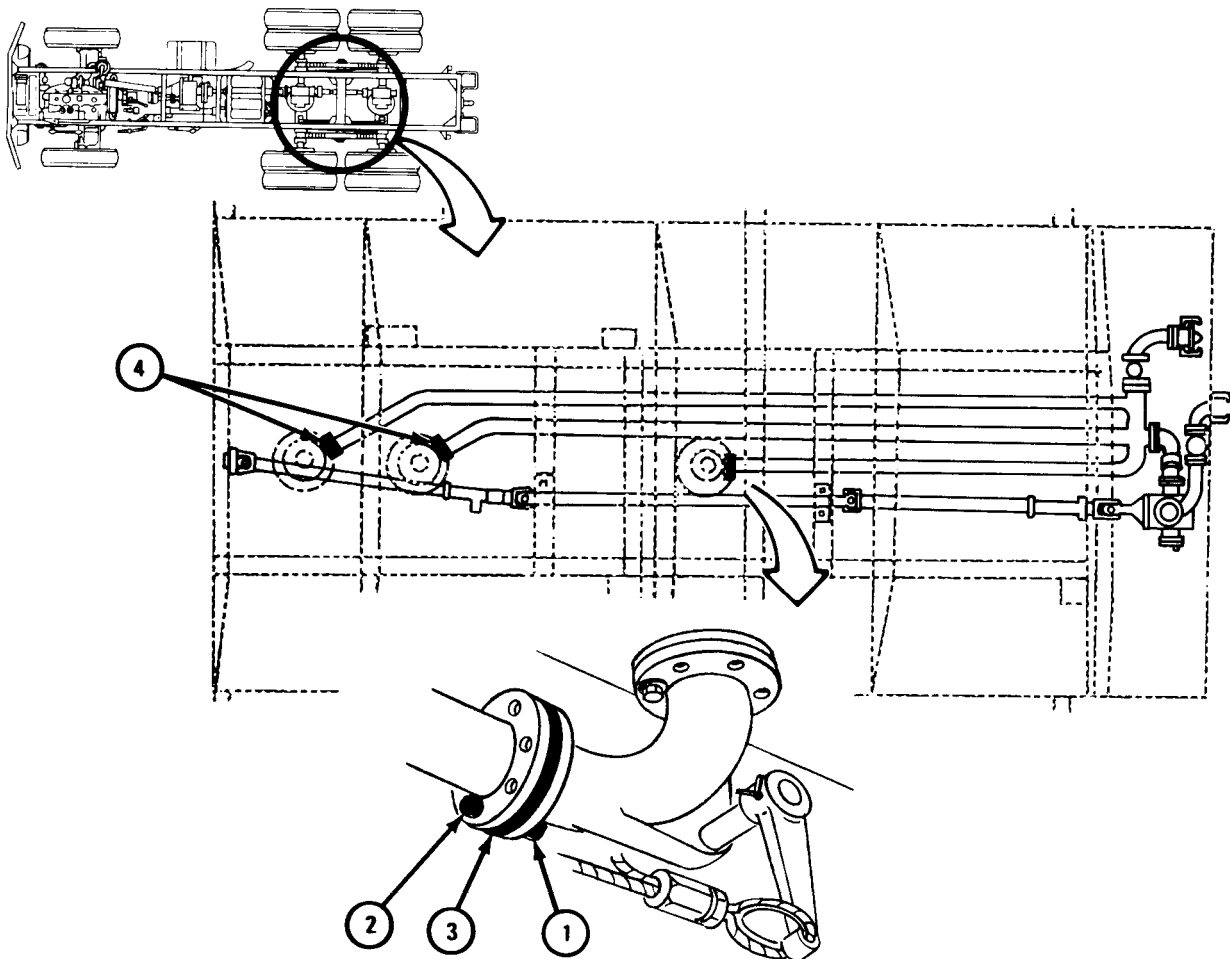

TA 104727

**FRAME 3**

Soldier A 1. Hold up discharge pipe (1).

Soldier B 2. Using 9/16-inch open end wrench, take off two nuts (2).

3. Takeout U-bolt (3).

4. Do steps 2 and 3 again for other three U-bolts (3).

Soldiers 5. Take out discharge pipe (1).

A and B

6. Do steps 1 through 5 again for other two discharge pipes (1).

END OF TASK

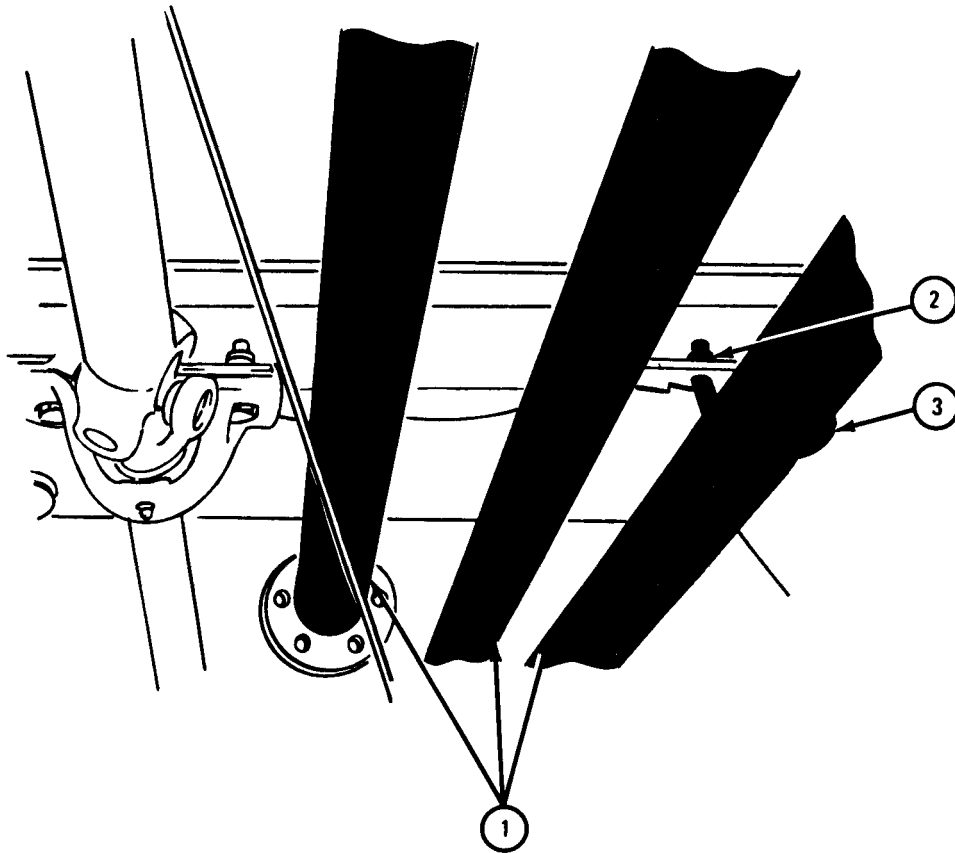

TA 104728



(2) Truck M49A2C.

FRAME 1

Soldiers 1. Open pump compartment doors.  
A and B

Soldier A 2. Using 7/8-inch open end wrench, unscrew and take off two nuts (1).

3. Take out two bolts (2).

Soldier B 4. Take off two halves of clamp (3).

5. Slide gasket (4) toward rear of truck.

Soldiers 6. Do steps 2 through 5 again for other discharge pipe clamp (3).  
A and B

GO TO FRAME 2

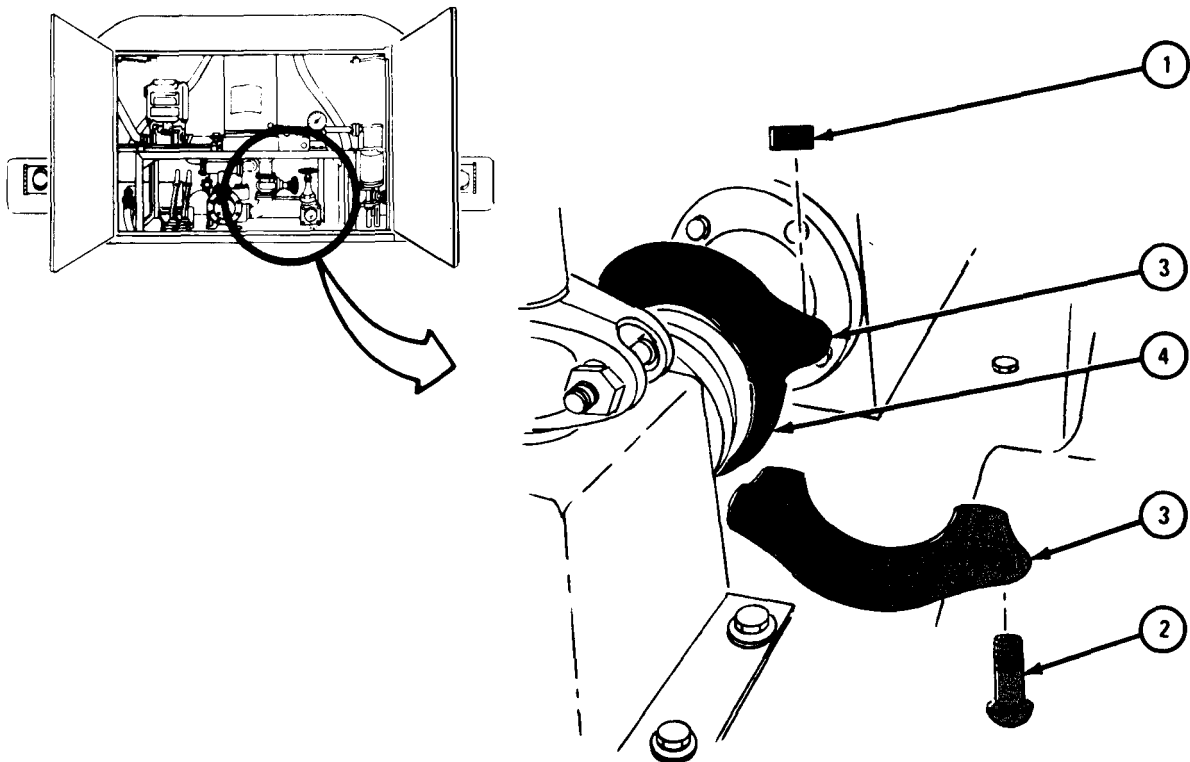

TA 104729

FRAME 2

- Soldier A 1. Using 9/16-inch socket wrench, extension, and ratchet, unscrew and take off two nuts (1).
- Soldier B 2. Take out two screws (2).
- Soldier A 3. Take off two halves of clamp (3).
- Soldier B 4. Slide gasket (4) onto discharge valve (5).
5. Do steps 1 through 4 again for other clamp (3).

GO TO FRAME 3

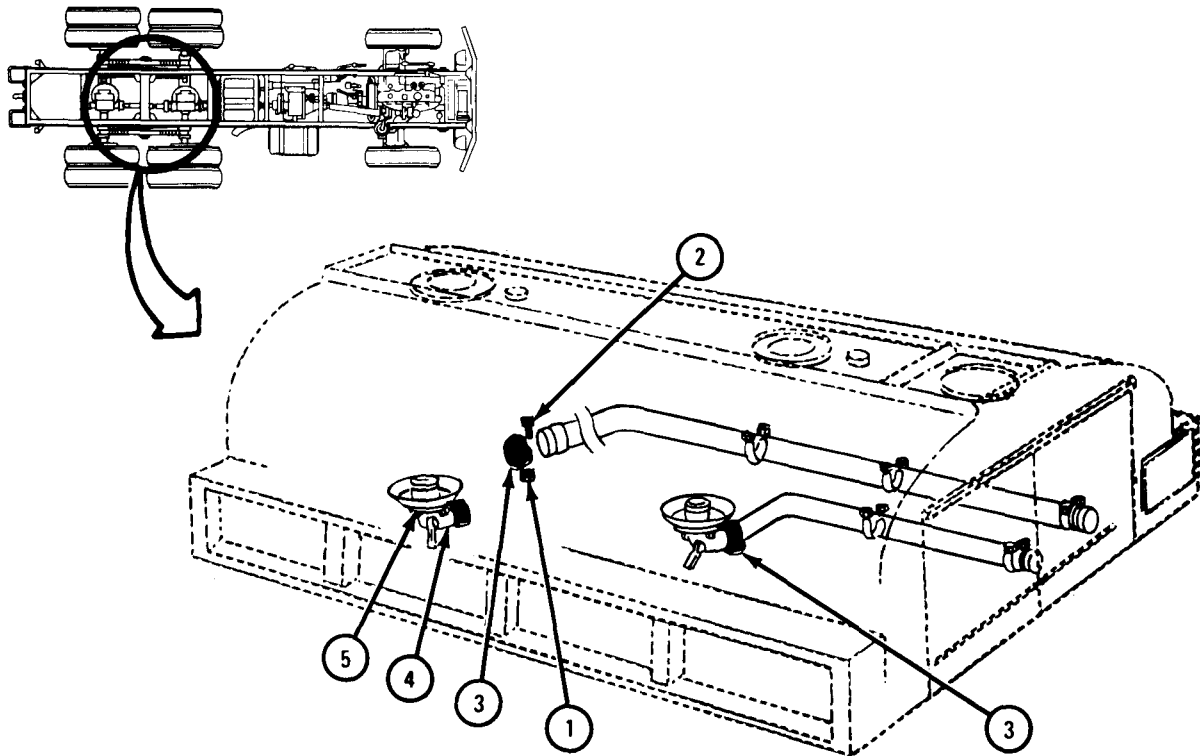

TA 104730

## FRAME 3

- Soldier A 1. Hold up discharge pipe (1).
- Soldier B 2. Using 3/4-inch open end wrench, unscrew and take off two nuts (2).
3. Take out U-bolt (3).
4. Do steps 2 and 3 again for other three U-bolts (3).
- Soldiers A and B 5. Take out discharge pipe (1).
- NOTE
- Discharge pipe (4) has two U-bolts (3).
6. Do steps 1 through 5 again for other discharge pipe (4).

END OF TASK

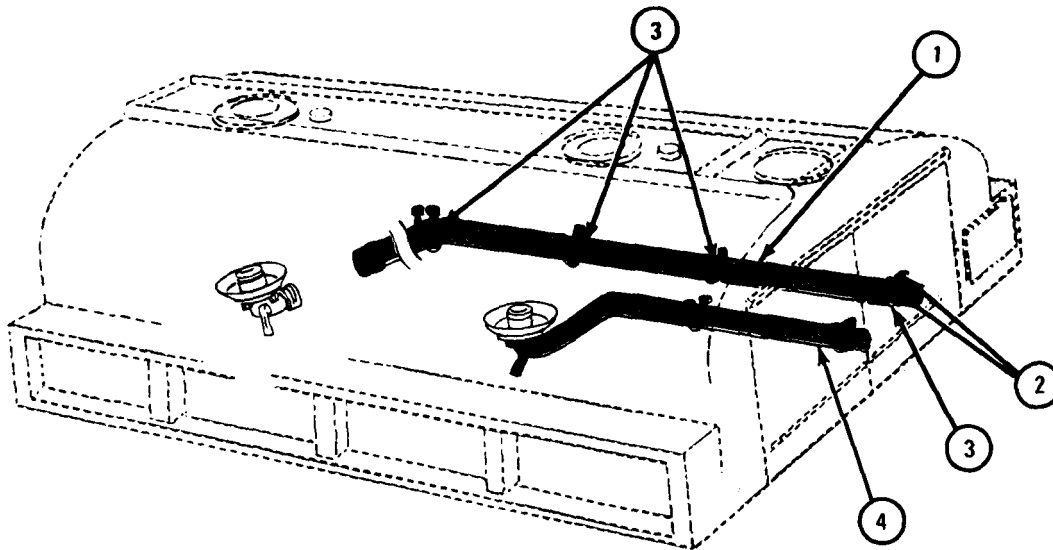

TA 104731

c. Replacement.

(1) Truck M49A1C.

**FRAME 1**

- Soldiers A and B 1. Put discharge pipe (1) in place.
- Soldier A 2. Hold up discharge pipe (1).
- Soldier B 3. Put in U-bolt (2).
4. Using 9/16-inch open end wrench, screw on and tighten two nuts (3).
5. Do steps 3 and 4 again for other three U-bolts (2).
- Soldiers A and B 6. Do steps 1 through 5 again for other two discharge pipes (1).

GO TO FRAME 2

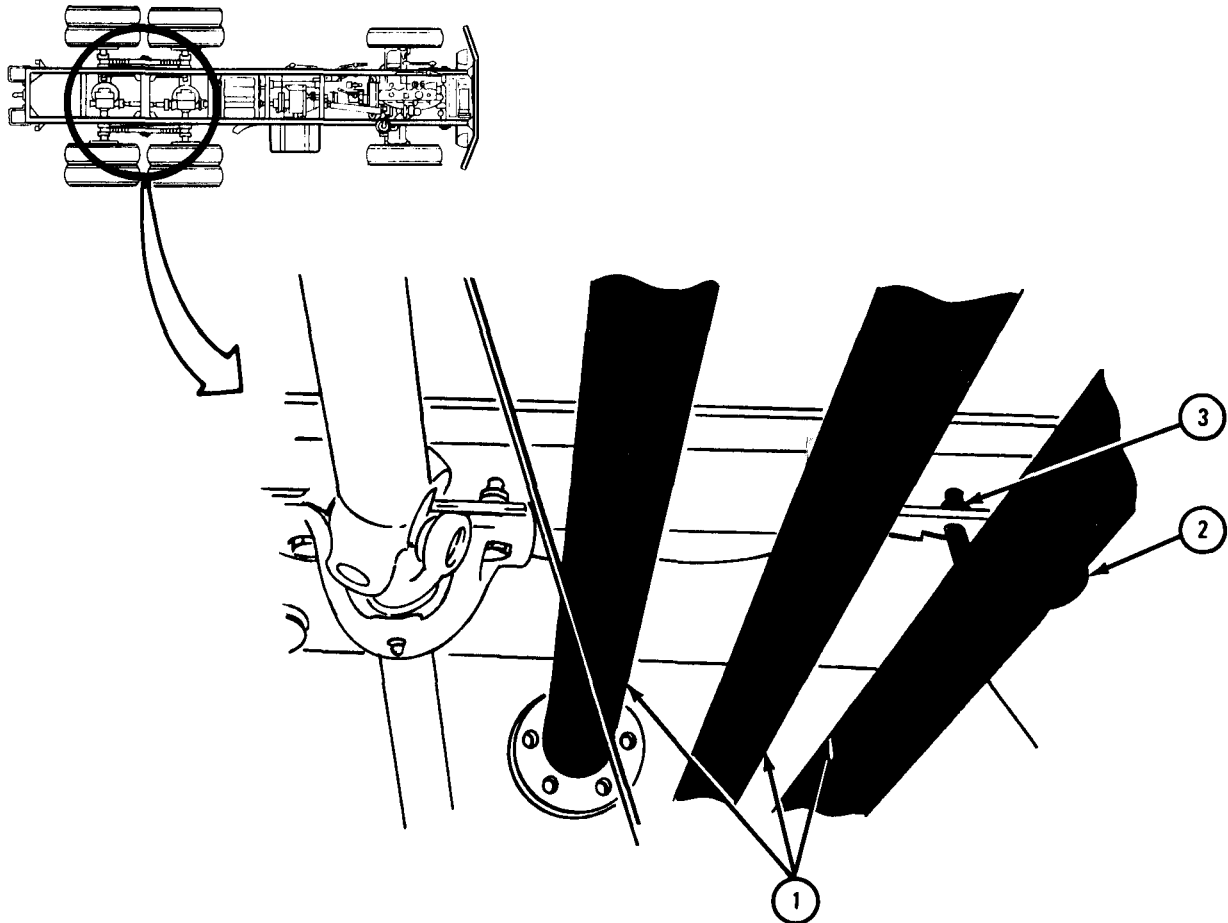

TA 104732

**FRAME 2**

- Soldier A 1. Put gasket (1) between discharge pipe (2) and discharge valve (3) and align holes.
- Soldier B 2. Put in six screws (4).
3. Using 9/16-inch open end wrench, hold six screws (4).
- Soldier A 4. Using 9/16-inch socket wrench, universal, extension, and ratchet, screw on and tighten six nuts (5).
- Soldiers A and B 5. Do steps 1 through 4 again for other two discharge valves (3).
- GO TO FRAME 3

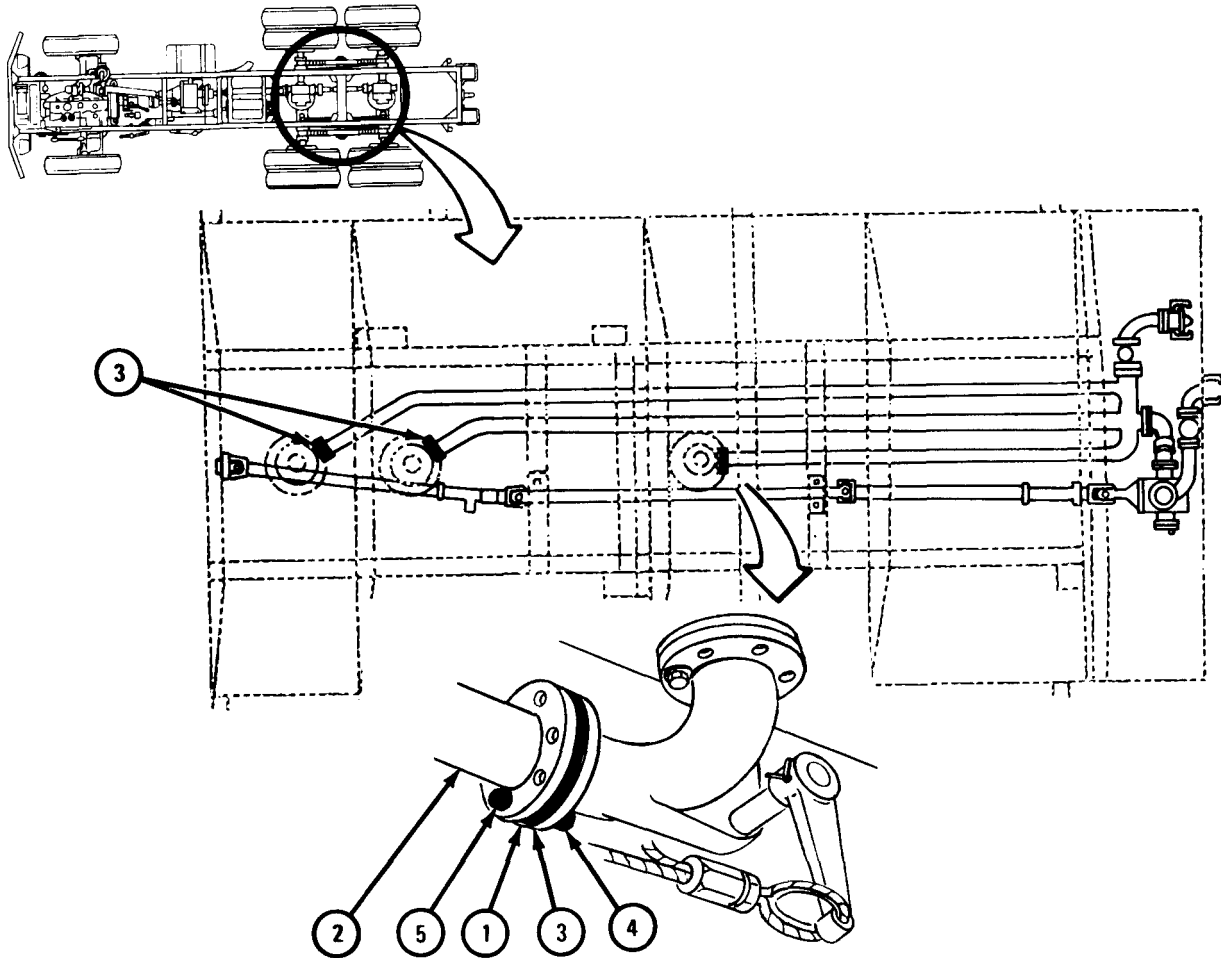

TA 104733

FRAME 3

- Soldier A
1. Slide gasket (1) toward front of truck.
  2. Put on two halves of clamp (2) and hold them in place.
- Soldier B
3. Put in two bolts (3).
  4. Using 5/8-inch open end wrench, screw on and tighten two nuts (4).
- Soldiers A and B
5. Do steps 1 through 4 again for other two discharge pipe clamps (2).

NOTE

Follow-on Maintenance Action Required:  
 Fill holding compartments with fuel. Refer to  
 TM 9-2320-209-10.

END OF TASK

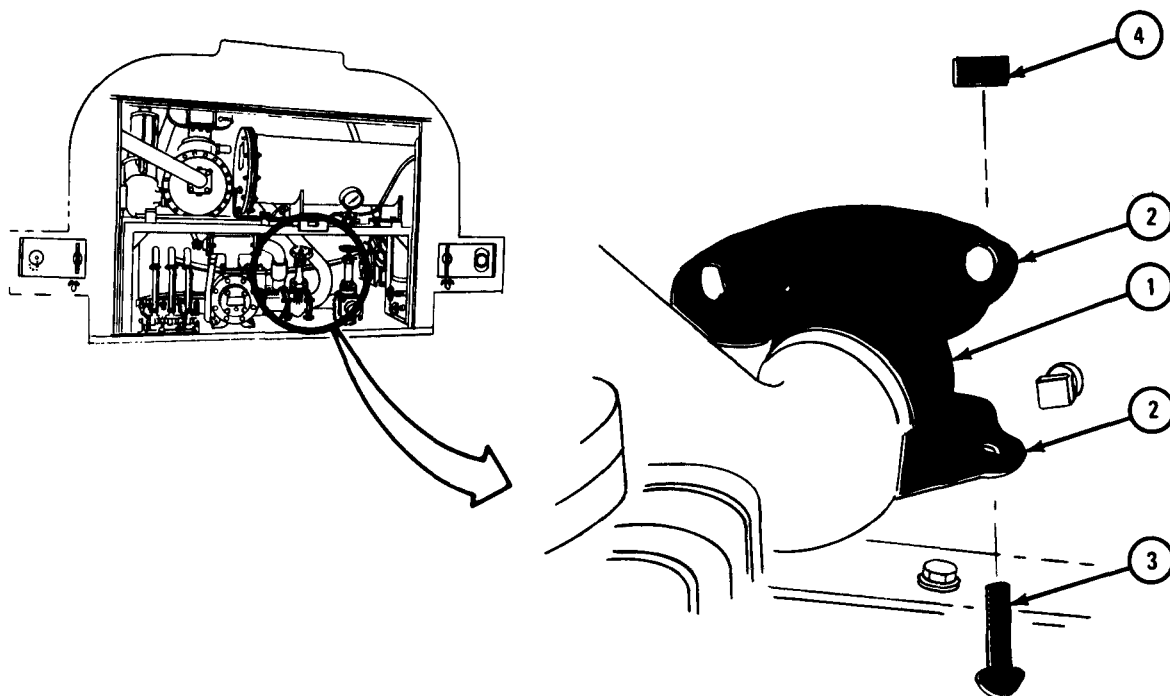

TA 104734

(2) Truck M49A2C.

### FRAME 1

- Soldiers A and B
1. Put discharge pipe (1) in place.
- Soldier A
2. Hold up discharge pipe (1).
- Soldier B
3. Put in U-bolt (2).
  4. Using 3/4-inch open end wrench, screw on and tighten two nuts (3).

#### NOTE

Discharge pipe (4) has two U-bolts (2).

5. Do steps 3 and 4 again for other three U-bolts (2).

- Soldiers A and B
6. Do steps 1 through 5 again for other discharge pipe (4).

GO TO FRAME 2

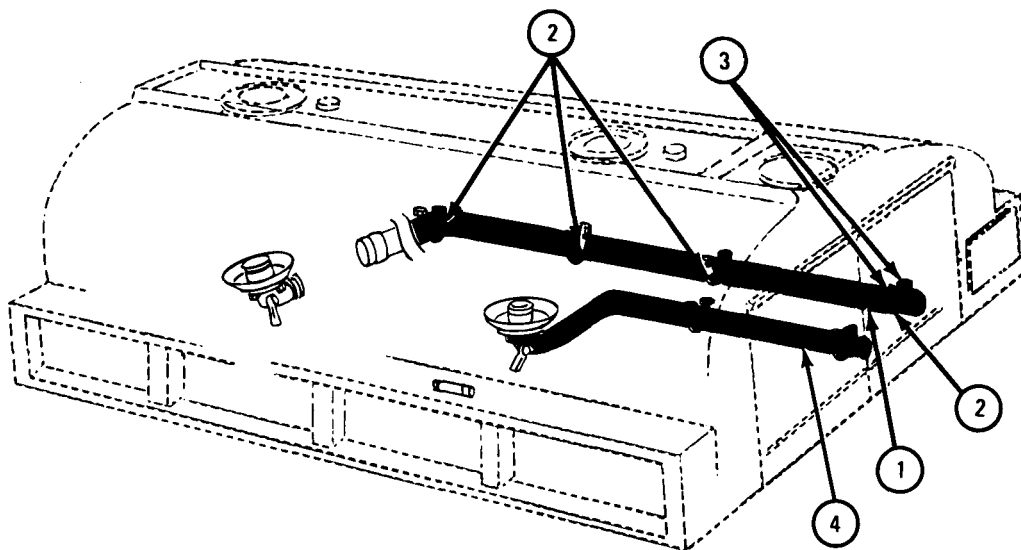

TA 104735

FRAME 2

Soldier A 1. Slide gasket (1) halfway onto discharge pipe (2).

2. Put on two halves of clamp (3) and hold them in place.

Soldier B 3. Put in two screws (4).

4. Using 7/8-inch socket wrench, extension, and ratchet, screw on and tighten two nuts (5).

Soldiers 5. Do steps 1 through 4 again for other discharge pipe (2).

A and B

GO TO FRAME 3

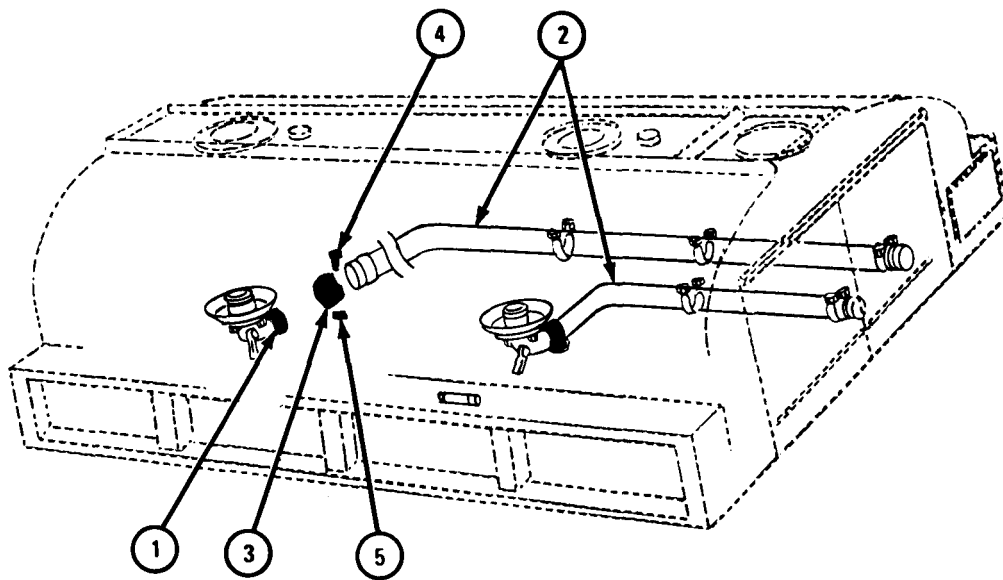

TA 104736



## FRAME 3

- Soldier A
1. Slide gasket (1) towards front of truck.
  2. Put on two halves of clamp (2) and hold them in place.
- Soldier B
3. Put in two bolts (3).
  4. Using 7/8-inch open end wrench, screw on and tighten two nuts (4).
- Soldiers A and B
5. Do steps 1 through 4 again for other discharge pipe clamp (2).

## NOTE

Follow-on Maintenance Action Required:  
 Fill holding compartments with fuel. Refer to  
 TM 9-2320-209-10.

END OF TASK

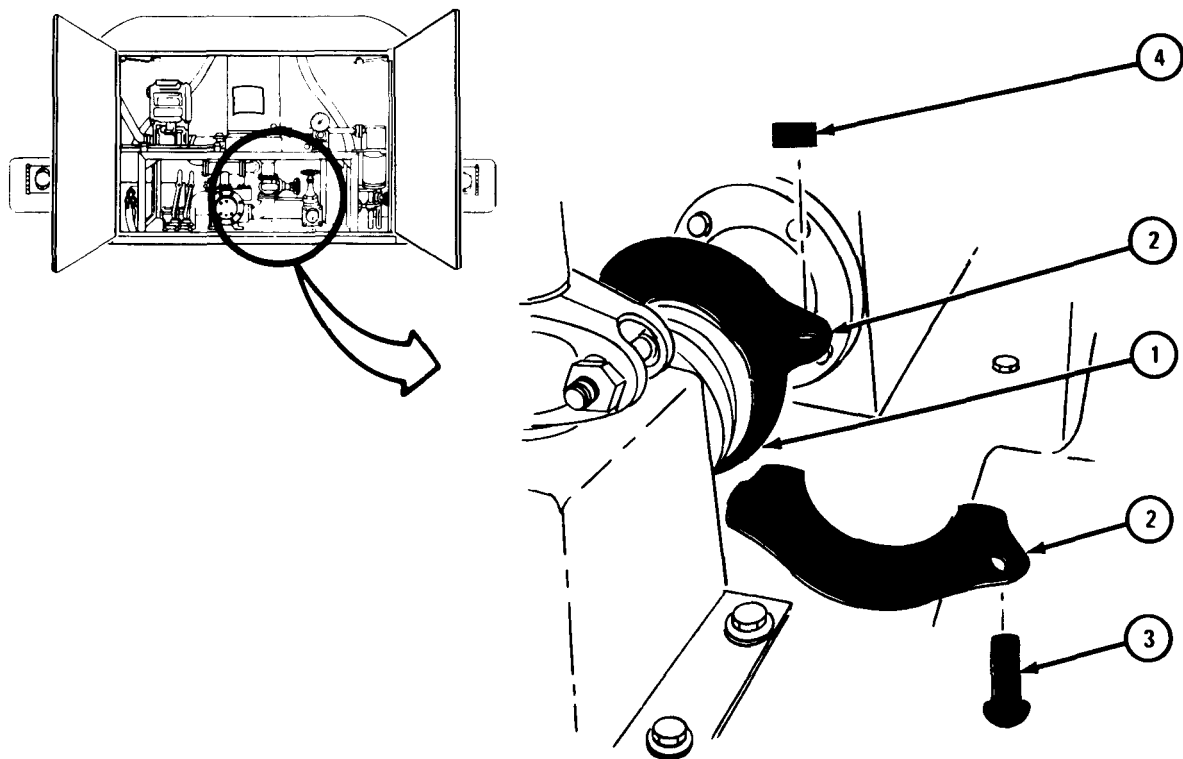

TA 104737

18-22. GATE VALVE REMOVAL AND REPLACEMENT (TRUCKS M49A1C AND M49A2C).

WARNING

Smoking, sparks or open flame are not allowed within 50 feet of fuel truck during this task. Fuel may burn, causing explosion, injury to personnel, and damage to equipment.

TOOLS: 3/4-inch wrench (2)

SUPPLIES: Gate valve gaskets (2)

PERSONNEL: One

EQUIPMENT CONDITION: Truck parked, engine off, handbrake set.

a. Removal.

FRAME 1

1. Using wrenches, unscrew and take out four screws (1) and nuts (2) from flange (3) on left side of gate valve (4).
2. Do step 1 again for the four screws and nuts on flange (3) on right side of gate valve (4).
3. Take away gate valve (4) and two gaskets (5).

END OF TASK

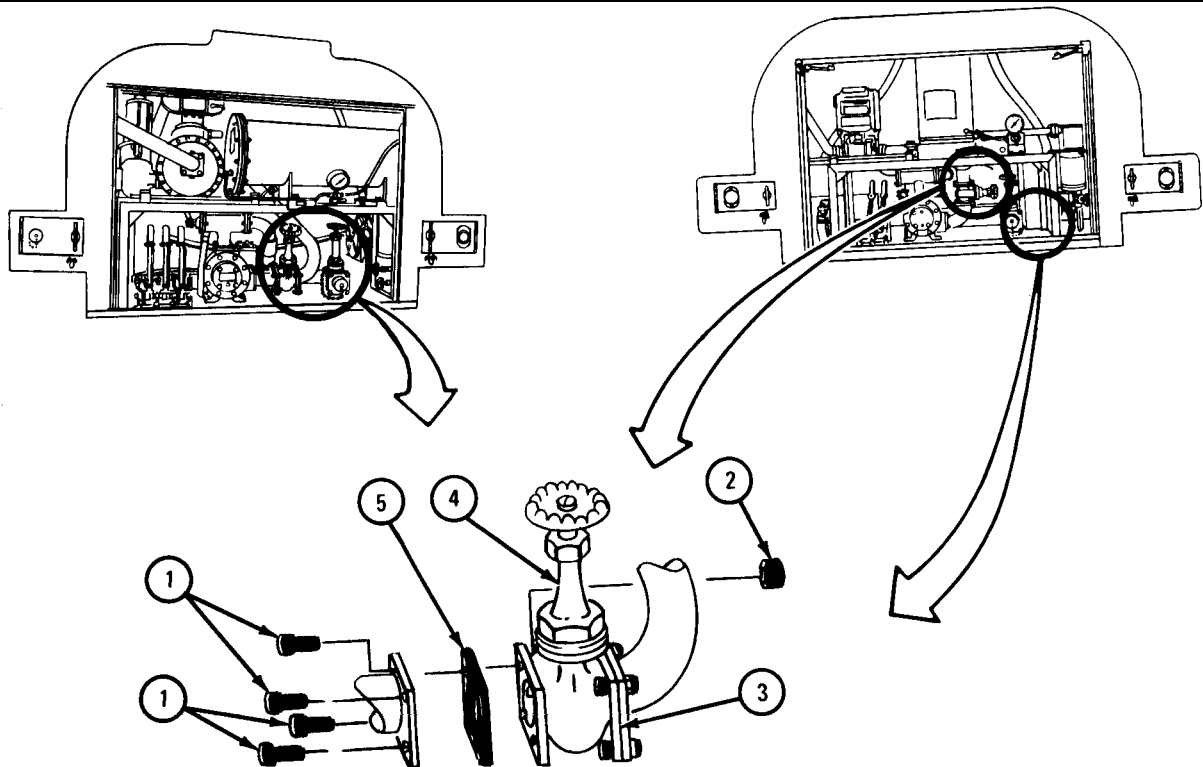

TA 046432

b. Replacement.

## FRAME 1

1. Put gaskets (1) on flanges (2 and 3). Put gate valve (4) between gaskets and line up screw holes.
2. Put eight screws (5) through flanges (2 and 3) and valve (4). Using wrenches, screw on and tighten eight nuts (6).

END OF TASK

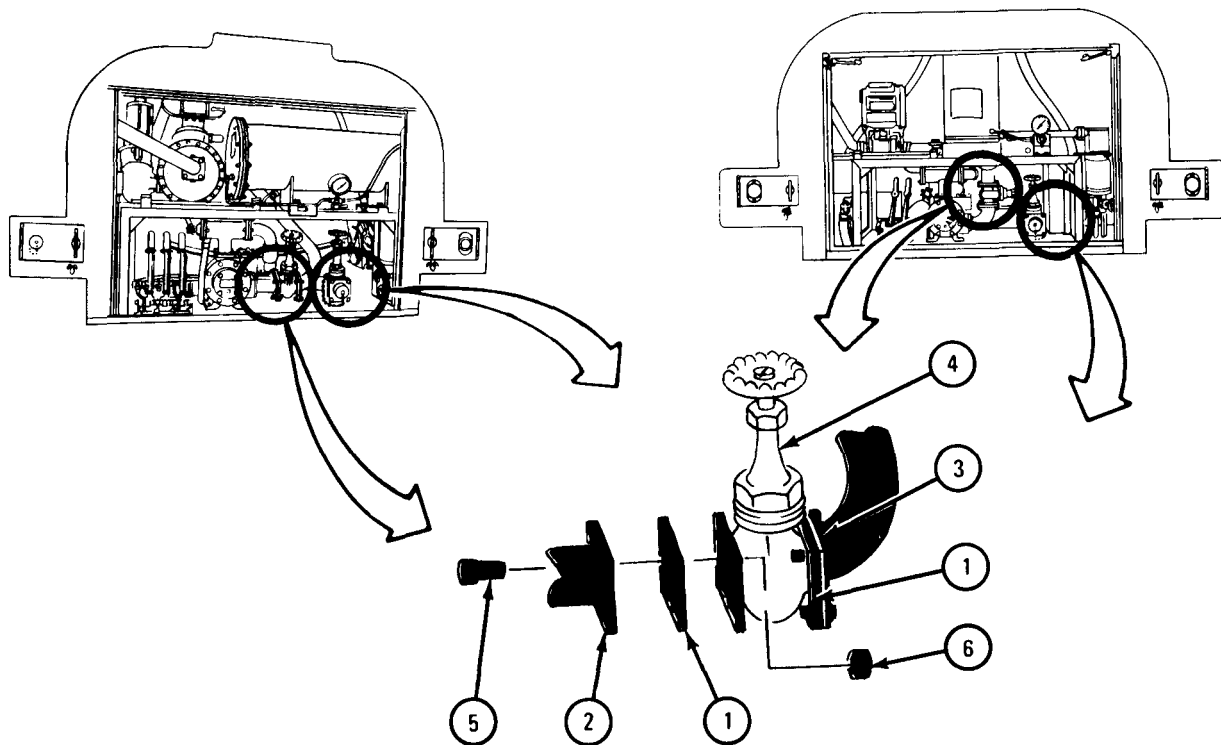

TA 046433

18-23. GATE VALVE PACKING REMOVAL AND REPLACEMENT (TRUCKS M49A1C AND M49A2C).

WARNING

Smoking, sparks or open flame are not allowed within 50 feet of fuel truck during this task. Fuel may burn, causing explosion, injury to personnel, and damage to equipment.

TOOLS: 1 9/16-inch wrench  
Pick

SUPPLIES: Gate valve preformed packing

PERSONNEL: One

EQUIPMENT CONDITION: Truck parked, engine off, handbrake set.

a. Removal.

FRAME 1

1. Using 9/16-inch wrench, unscrew and take off nut (1).
2. Lift handwheel (2) off stem (3).
3. Using 1 9/16-inch wrench, unscrew and take off nut (4).
4. Using pick, take gland (5), upper packing (6) and lower packing (7) out of bonnet (8). Throw away packings.

END OF TASK

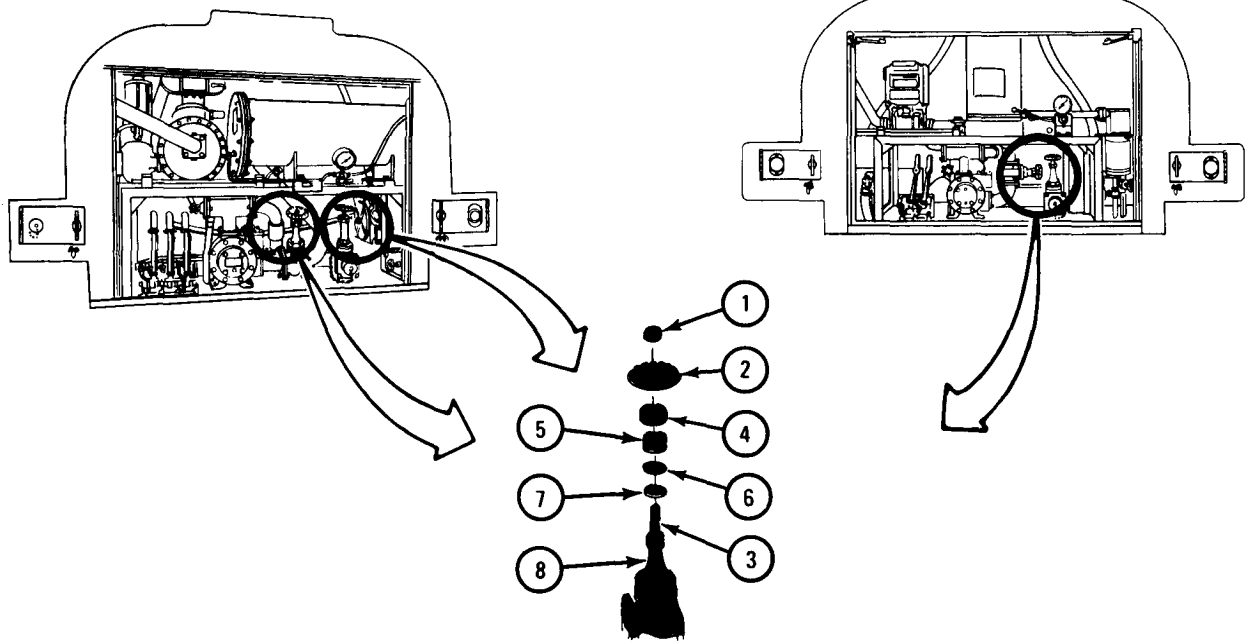

TA 046434

b. Replacement.

**FRAME 1**

1. Put lower packing (1) onto stem (2).
2. Put upper packing (3) onto stem (2).
3. Put gland (4) onto stem (2). Using gland as tool, push packings (1 and 3) into bonnet (5). Push gland into bonnet.
4. Using 1 9/16-inch wrench, screw on and tighten nut (6).
5. Put handwheel (7) onto stem (2).
6. Using 9/16-inch wrench, screw on and tighten nut (8).

END OF TASK

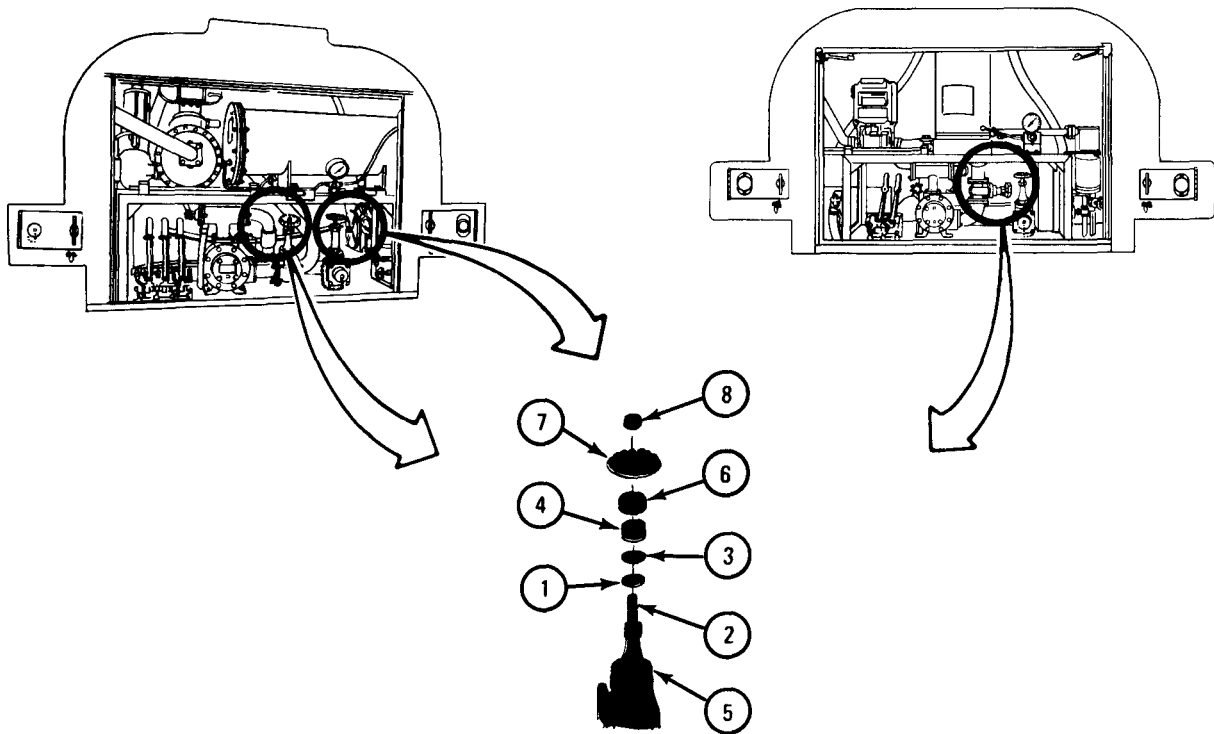

TA 046435

18-24. EMERGENCY RELEASE CABLE REMOVAL AND REPLACEMENT.

NOTE

Truck M49A1C has three discharge valve controls.  
Truck M49A2C has two discharge valve controls.  
This task is the same for both trucks.

TOOLS: 5/8-inch wrench  
1/2-inch wrench  
Pliers  
8-inch adjustable wrench  
Leather gloves

SUPPLIES: None

PERSONNEL: One

EQUIPMENT CONDITION: Truck parked, engine off, handbrake set,  
wheels chocked.

WARNING

Smoking, sparks, or open flame are not allowed within 50 feet of fuel truck during this task. Fuel may burn, causing explosion, injury to personnel, and damage to equipment.

Always wear protective gloves when handling cable. Do not let cable slip through hands. Rusty or broken wires can cause injury.

a. Removal.

## FRAME 1

1. Using adjustable wrench, hold split screw (1). Using 5/8-inch wrench, unscrew and take off nut (2) from split screw. Take off both parts of split screw.
2. Take cable (3) off from thimble (4). Slide nut (2) off cable.

GO TO FRAME 2

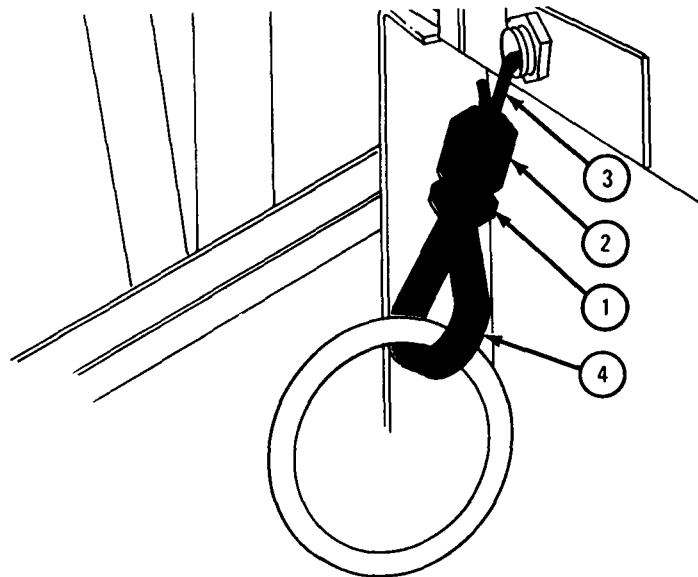
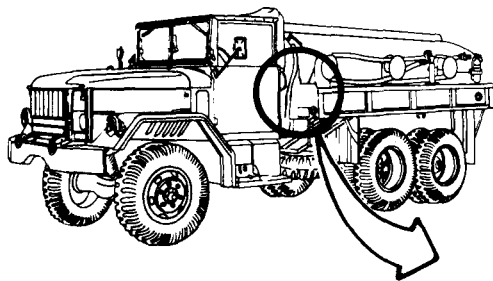

TA 046556

FRAME 2

1. Open truck rear compartment doors.
2. Using 1/2-inch wrench, loosen nut (1). Take cable (2) out of hole in special bolt (3).
3. Using pliers, pull cable (2) out of truck.

END OF TASK

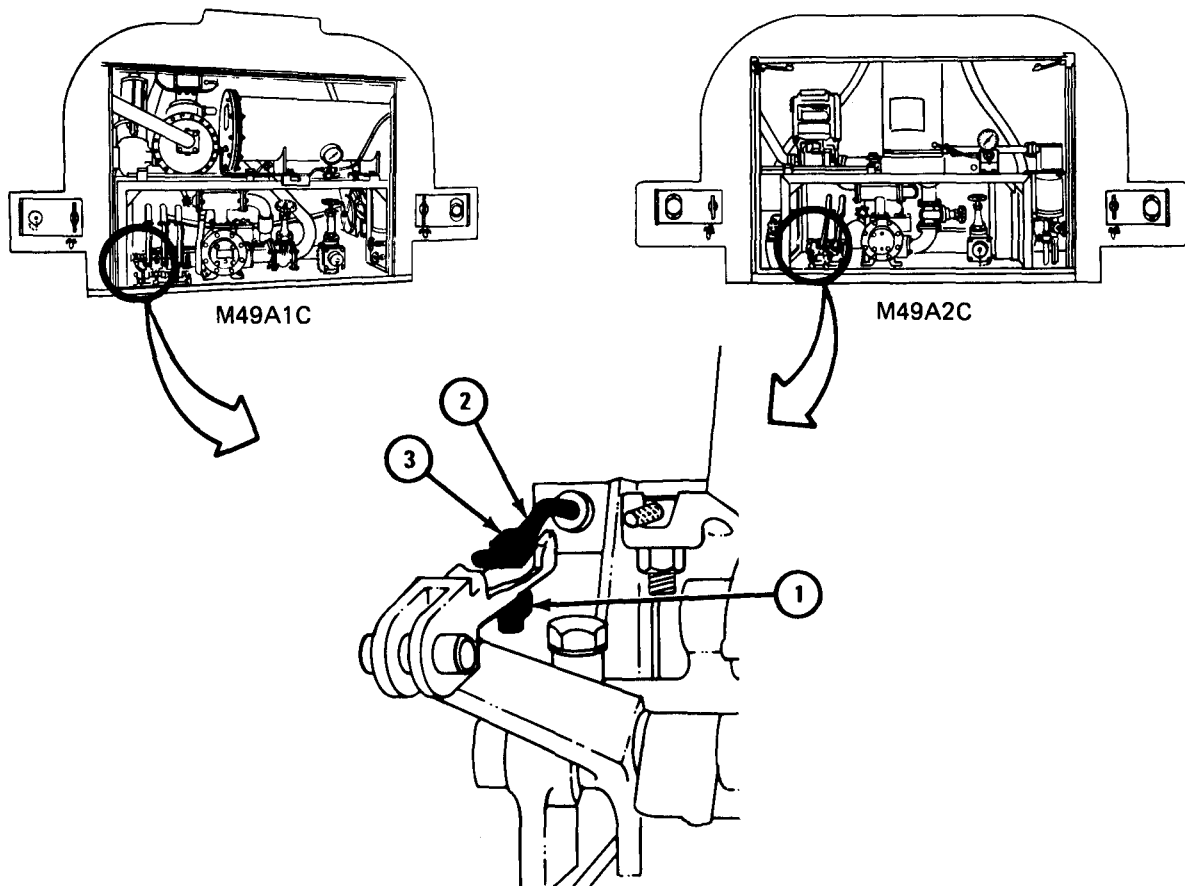

TA 046557



b. Replacement.

## FRAME 1

1. Put cable (1) through nut (2). Put cable around thimble (3) and back through nut again. Let about 1/2 inch of cable end come out of nut.
2. Put two halves of split screw (4) together around both parts of cable (1) and start nut (2).
3. Push nut (2) with split screw (4) against thimble (3).
4. Using adjustable wrench, hold split screw (4). Using 5/8-inch wrench, screw on and tighten nut (2).

GO TO FRAME 2

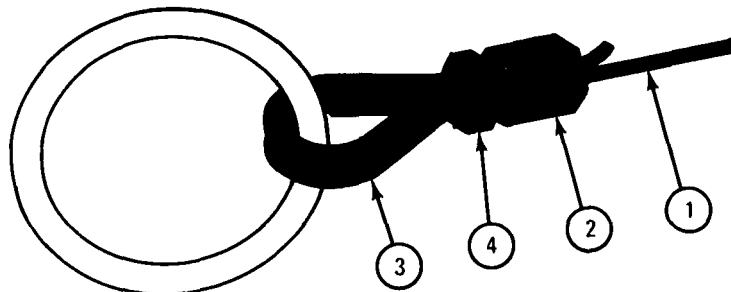

TA 046558

FRAME 2

1. Put end of cable (1) that does not have handle (2) through tube (3).
  2. Go under truck and find end of cable (1). Put cable through tube (4).
- GO TO FRAME 3

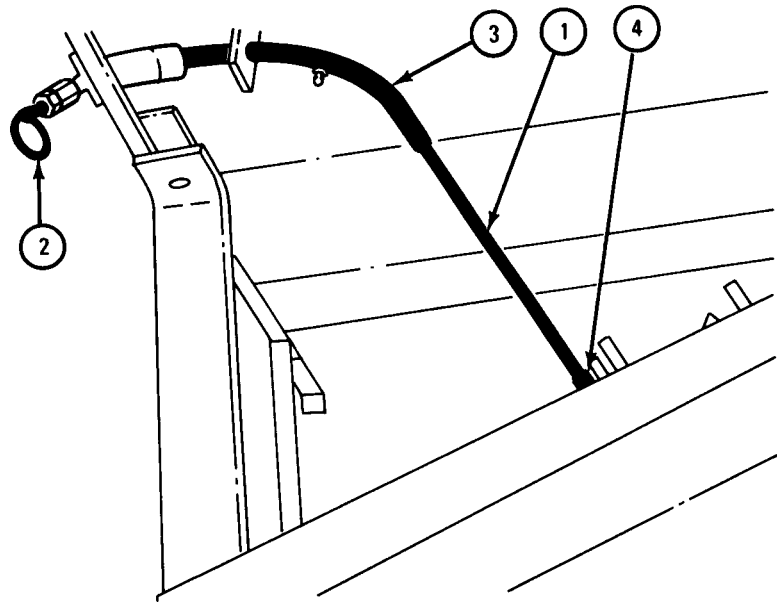
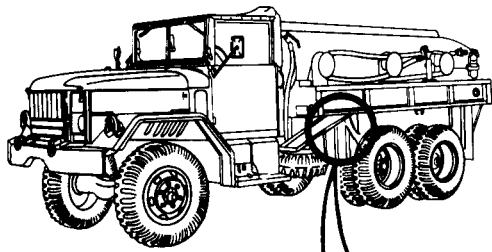

TA 046559

FRAME 3

1. Working from front to rear, under truck, put cable (1) through tube (2).
2. Push cable (1) through tube (3) and out rear of truck.

GO TO FRAME 4

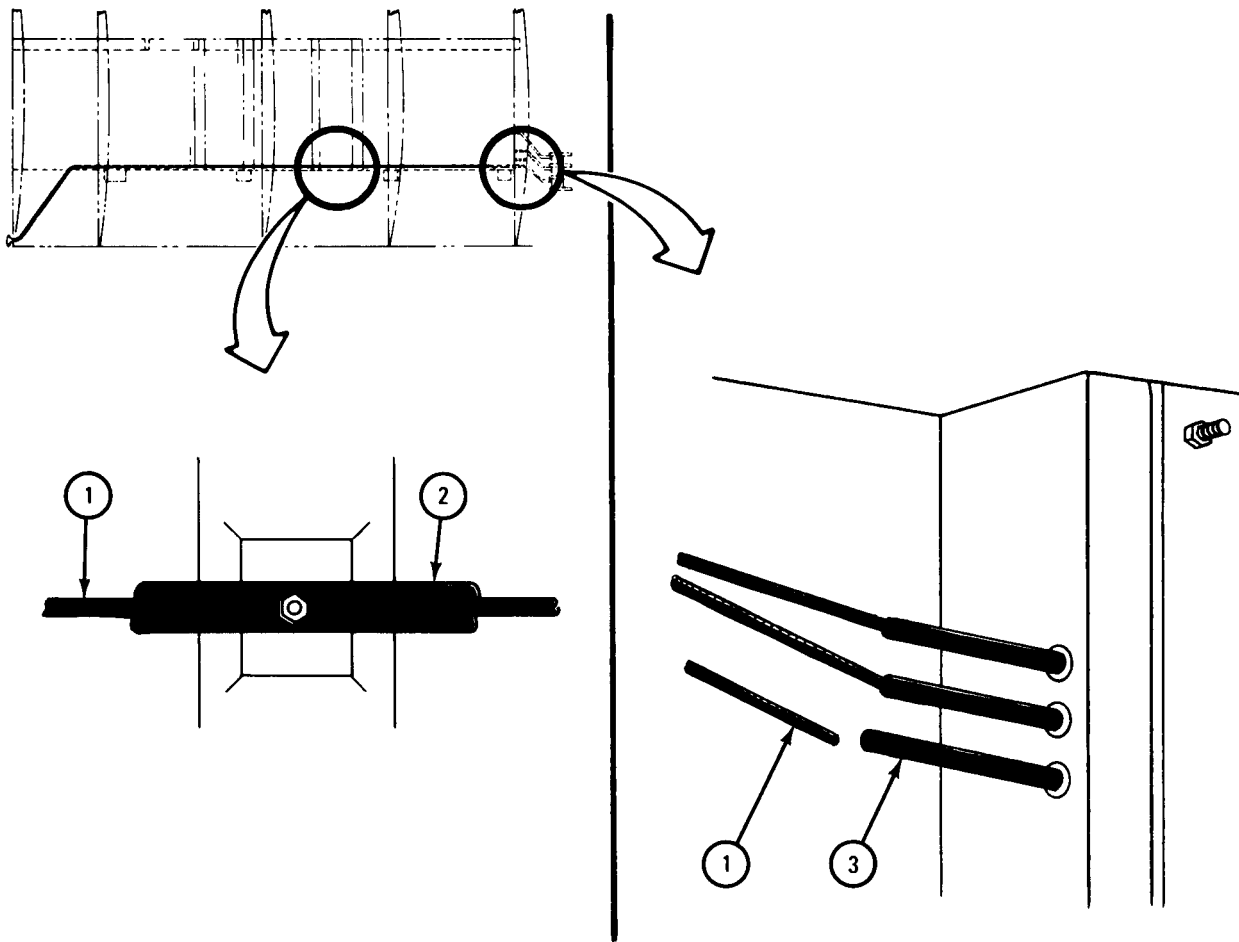

TA 046560

FRAME 4

1. Working from rear of truck in tank compartment (1) and using pliers, put end of cable (2) through special bolt (3).
2. Using pliers, pull most of slack out of cable (2).
3. Using 1/2-inch wrench, screw on and tighten nut (4) into place in lever (5).

NOTE

Follow-on Maintenance Action Required:

Lubricate tubes. Refer to LO 9-2320-209-12/1.

END OF TASK

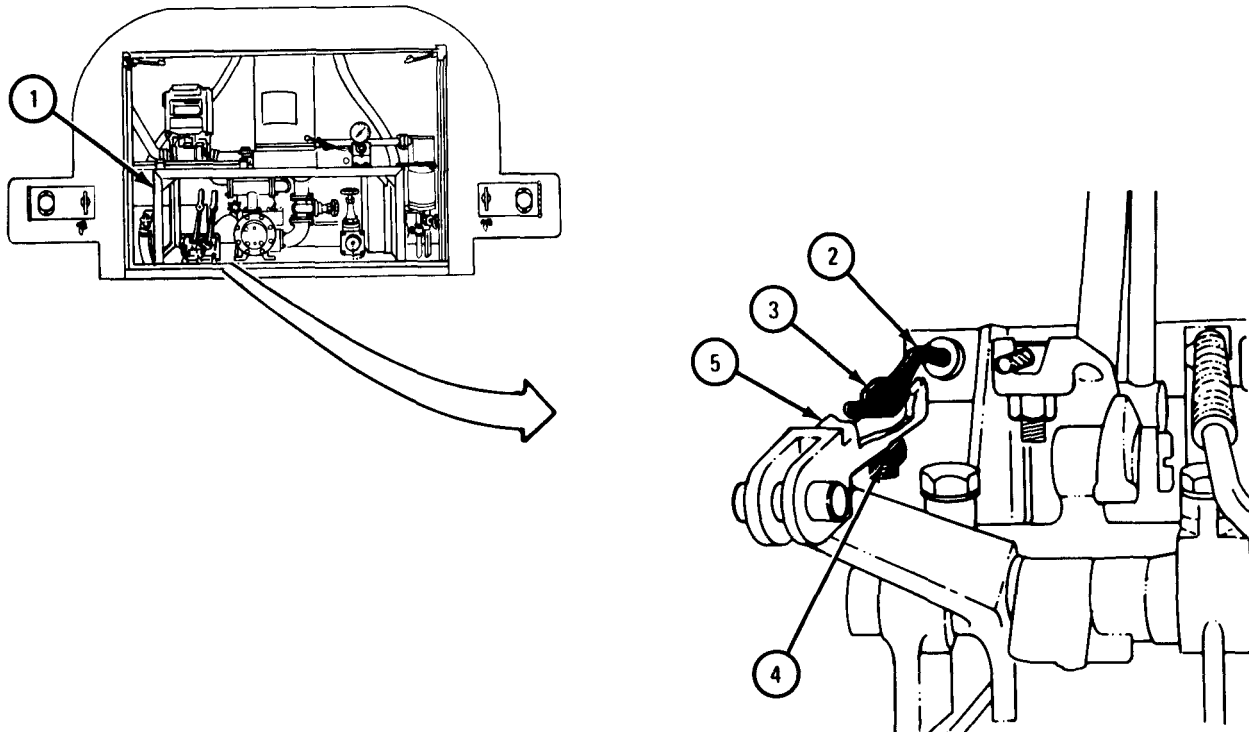

TA 046561

18-25. FRONT DISCHARGE VALVE CABLE REMOVAL AND REPLACEMENT (TRUCK M49A1C).

TOOLS: 5/8-inch wrench (2)  
 1/2-inch wrench  
 Pliers  
 Leather gloves

SUPPLIES: None

PERSONNEL: Two

EQUIPMENT CONDITION: Truck parked, engine off, handbrake set, wheels chocked.

**WARNING**

Smoking, sparks or open flame are not allowed within 50 feet of fuel truck during this task. Fuel may burn, causing explosion, injury to personnel, and damage to equipment.

Always wear protective gloves when handling cable. Do not let cable slip through hands. Rusty or broken wires can cause injury.

a. Removal.

**FRAME 1**

1. Open truck rear compartment doors.
2. Using 1/2-inch wrench, unscrew and take off nut (1). Take cable (2) out of special bolt (3).

GO TO FRAME 2

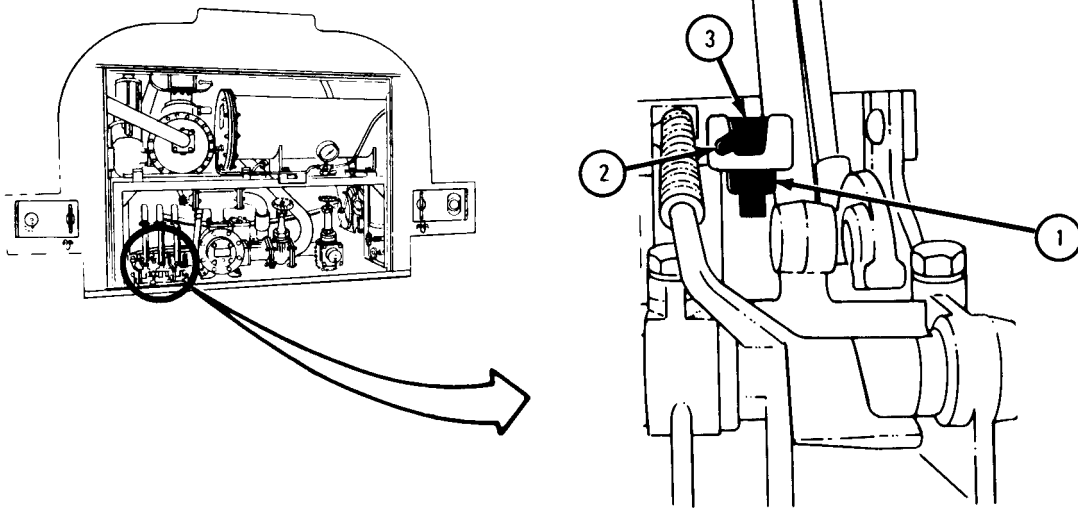

TA 046562

FRAME 2

1. Using 5/8-inch wrench, hold split screw (1). Using 5/8-inch wrench, unscrew and take off nut (2). Take off both parts of split screw.
2. Take cable end (3) out of nut (2) and valve lever (4). Take off nut from cable (5).
3. Cable (5) is now free on both ends. Take cable out of truck.

END OF TASK

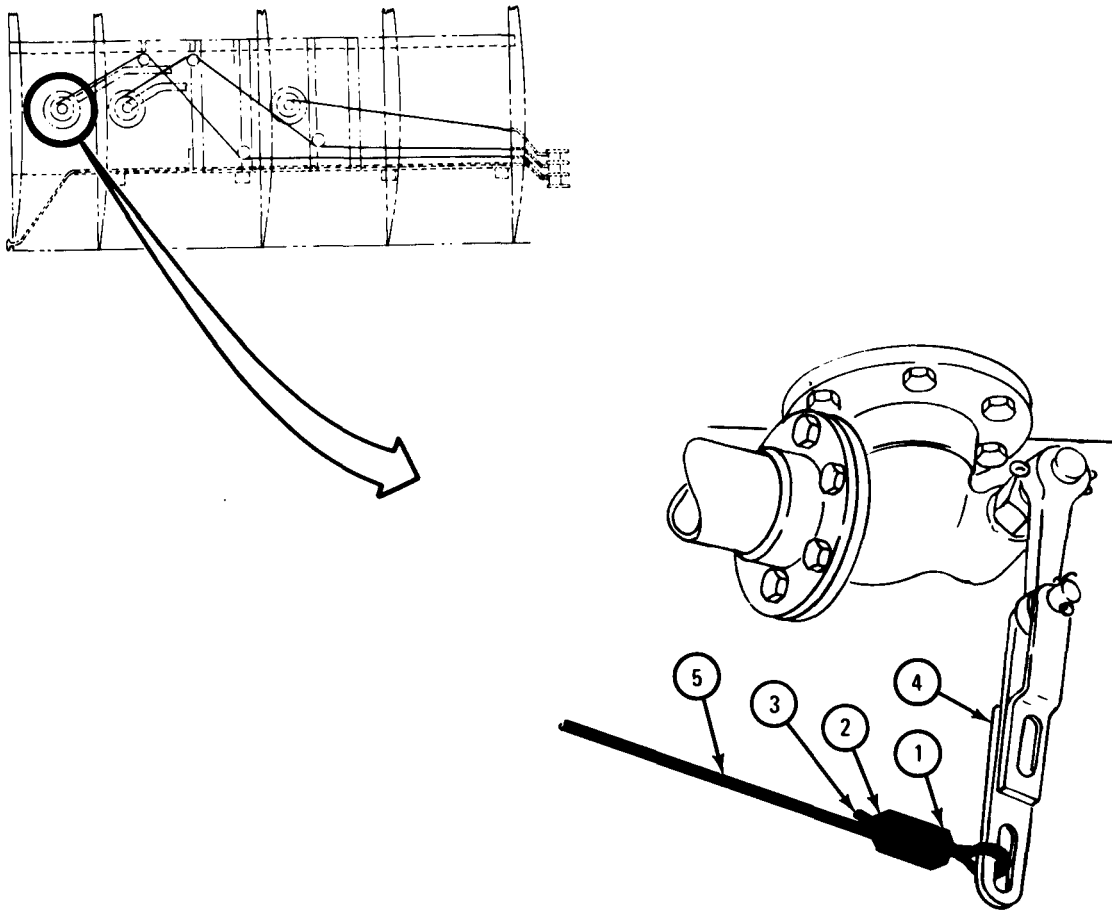

TA 046563

b. Replacement.

## FRAME 1

1. Put cable (1) through nut (2). Put cable through hole in valve lever (3) and back through nut, leaving a loose loop at valve lever. Let about 1/2 inch of cable end come out of nut.
2. Put two halves of split screw (4) together around both parts of cable (1) and screw on nut (2).
3. Using 5/8-inch wrench, hold split screw (4). Using 5/8-inch wrench, tighten nut (2) to split screw.

GO TO FRAME 2

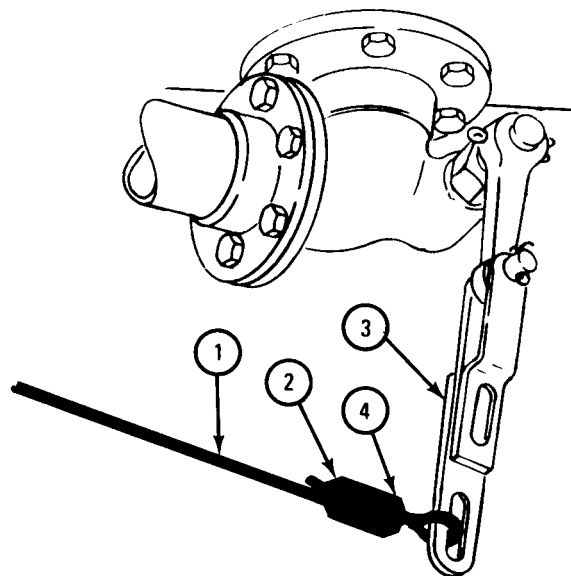
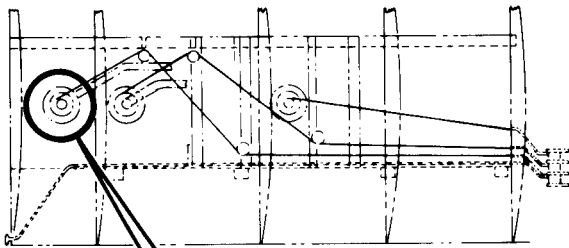

TA 046564

FRAME 2

Soldier A 1. Working from front to back of truck, put cable (1) through two sheaves (2). Make sure cable is routed as shown and that it will not rub on any truck parts.

Soldier B 2. Put discharge lever (3) for front discharge valve in closed position. Refer to TM 9-2320-209-10.

GO TO FRAME 3

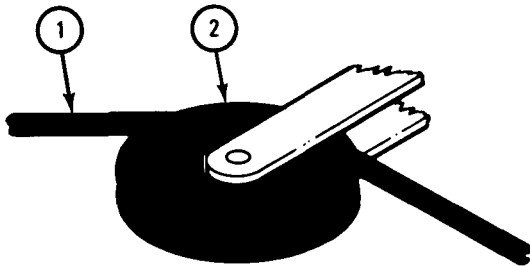
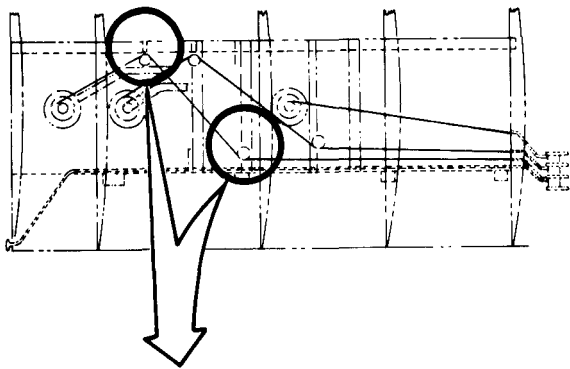

SOLDIER A

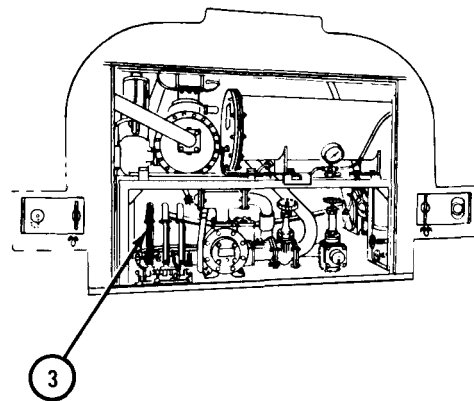

SOLDIER B

TA 046565



FRAME 3

- Soldier A 1. Put cable (1) through tube (2) and tell soldier B to take end of cable.
- Soldier B 2. Using pliers, put cable end (3) through hole in special bolt (4).  
 3. Put special bolt (4) in arm (5). Pull cable end (3) to take out most of the slack. Using 1/2-inch wrench, screw and tighten nut (6).  
 4. Close truck rear compartment doors.

NOTE

Follow-on Maintenance Action Required:  
 Lubricate cable. Refer to LO 9-2320-209-12/1.

END OF TASK

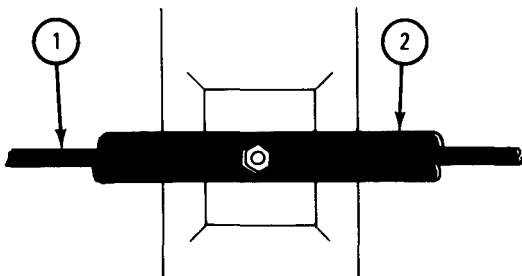
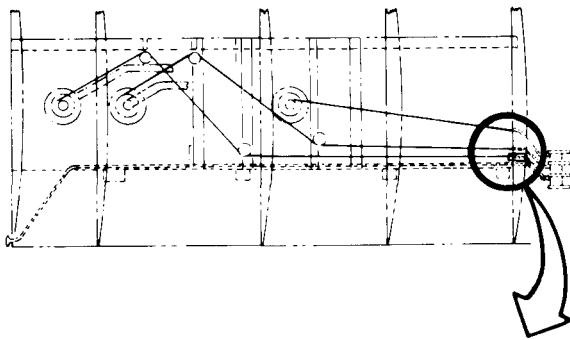

SOLDIER A

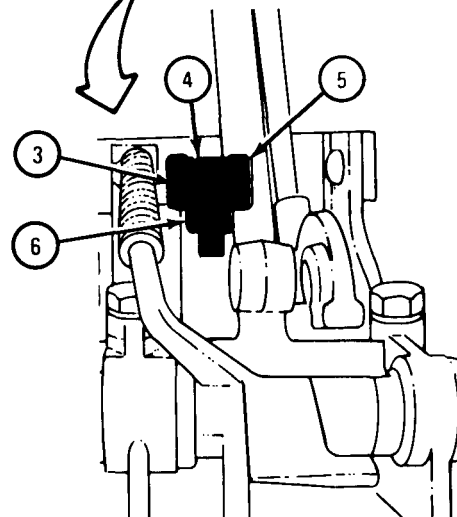
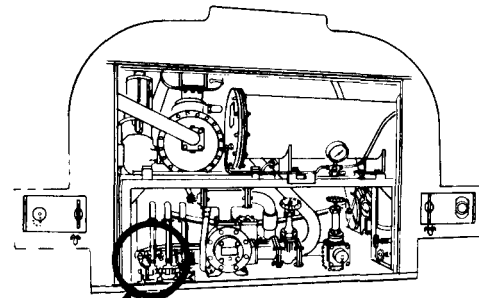

SOLDIER B

TA 046566

### 18-26. FRONT DISCHARGE VALVE CABLE REMOVAL AND REPLACEMENT (TRUCK M49A2C).

TOOLS: 1/2-inch wrench                                  Leather gloves  
          7/16-inch wrench                                Pliers

SUPPLIES: None

PERSONNEL: Two

EQUIPMENT CONDITION: Truck parked, engine off, handbrake set, wheels chocked.

WARNING

Smoking, sparks or open flame are not allowed within 50 feet of fuel truck during this task. Fuel may burn, causing explosion, injury to personnel, and damage to equipment.

Always wear protective gloves when handling cable. Do not let cable slip through hands. Rusty or broken wires can cause injury.

a. Removal.

FRAME 1

1. Open truck rear compartment doors.
  2. Using 1/2-inch wrench, loosen nut (1). Take cable (2) out of special bolt (3).
- GO TO FRAME 2

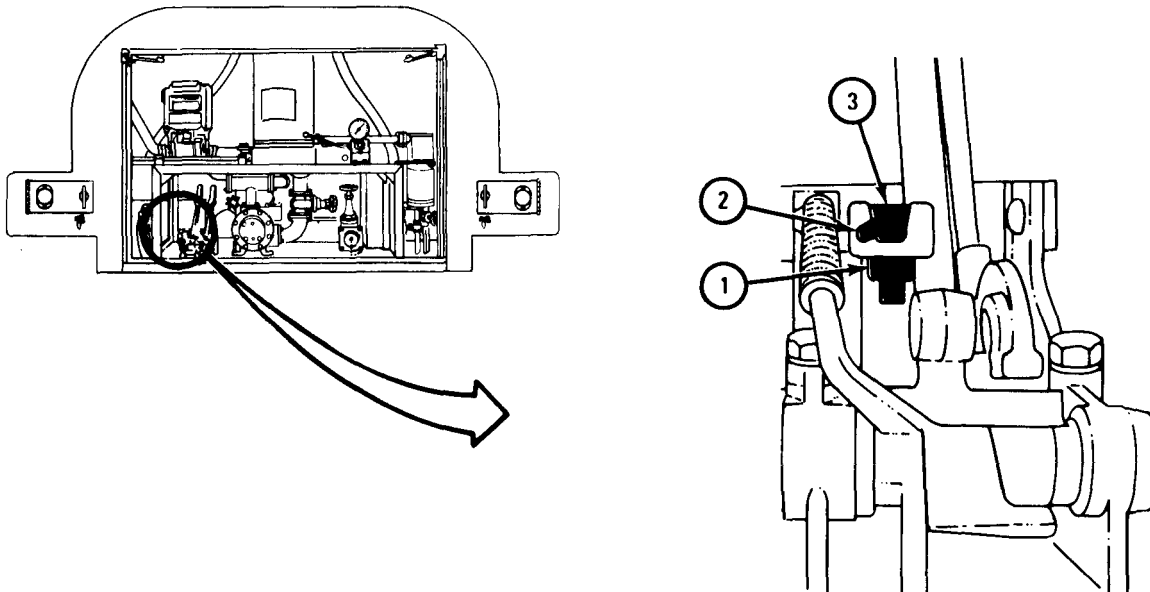

TA 046576

## FRAME 2

1. Working under front of truck using 7/16-inch wrench, unscrew and take off two nuts (1). Take off plate (2) and U-bolt (3). Cable (4) will be free of valve lever (5).
2. Cable (4) is now free on both ends. Take cable out of truck.

END OF TASK

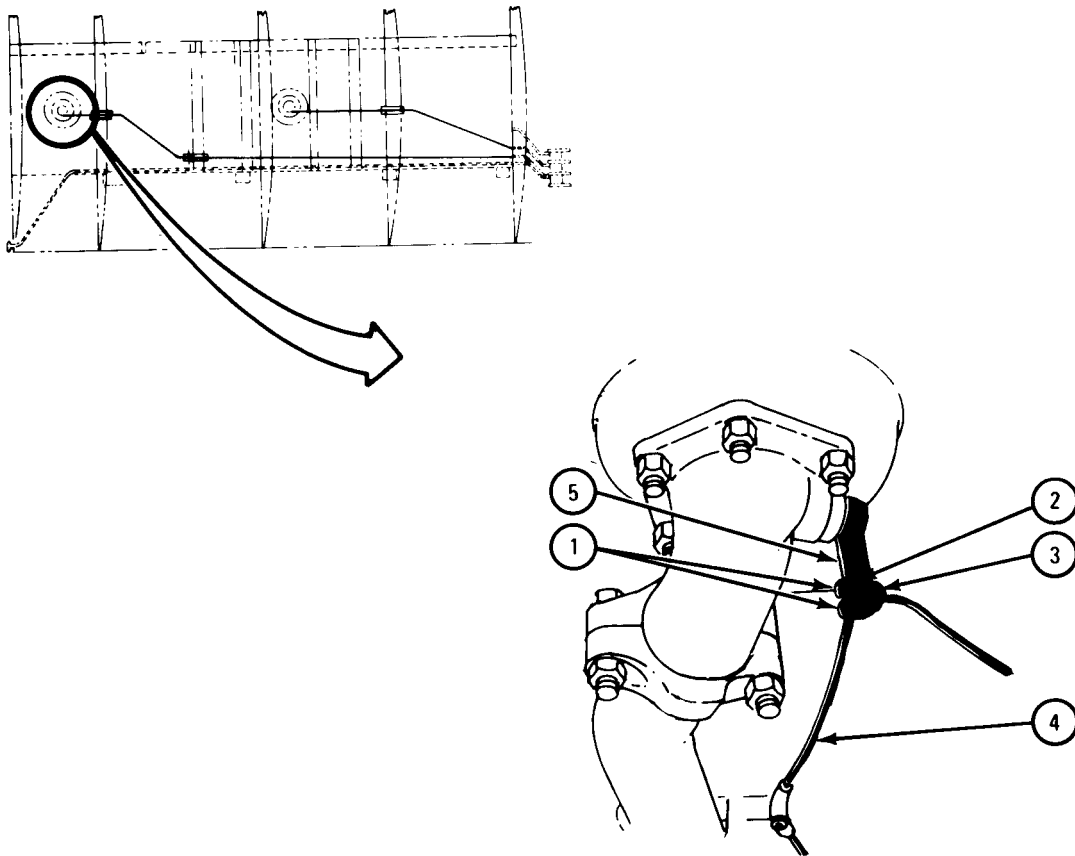

TA 046577

b. Replacement.

FRAME 1

1. Put cable (1) to valve lever (2) so it will be held by U-bolt (3). Put U-bolt through holes in valve lever.
2. Put plate (4) on U-bolt (3). Screw on two nuts (5) to U-bolt.
3. Using 7/16-inch wrench, tighten two nuts (5).

GO TO FRAME 2

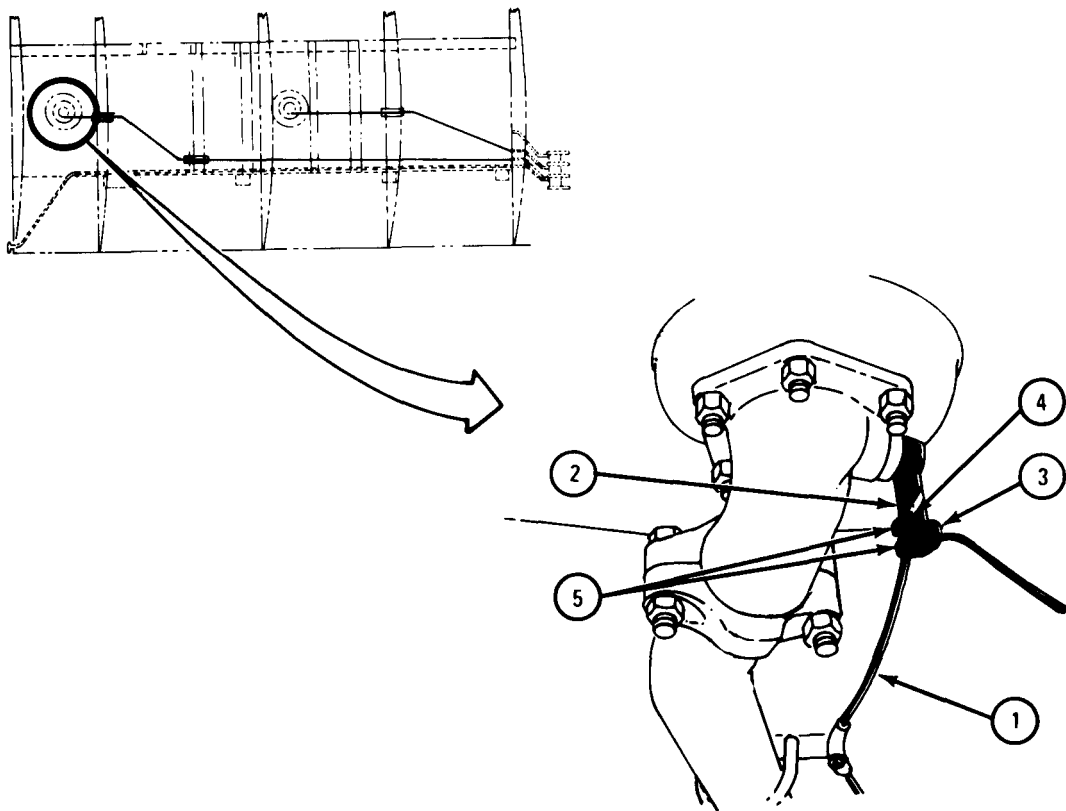

TA 046578

FRAME 2

Soldier A 1. Put discharge lever (1) for front discharge valve in the closed position. Refer to TM 9-2320-209-10.

Soldier B 2. Working from front to back of truck, put cable (2) through three tubes (3). When you have cable through all three tubes, tell soldier A to take end of cable.

Soldier A 3. Using pliers, put cable end (4) through hole in special bolt (5). Using pliers, hold cable so it does not come out of special bolt.

GO TO FRAME 3

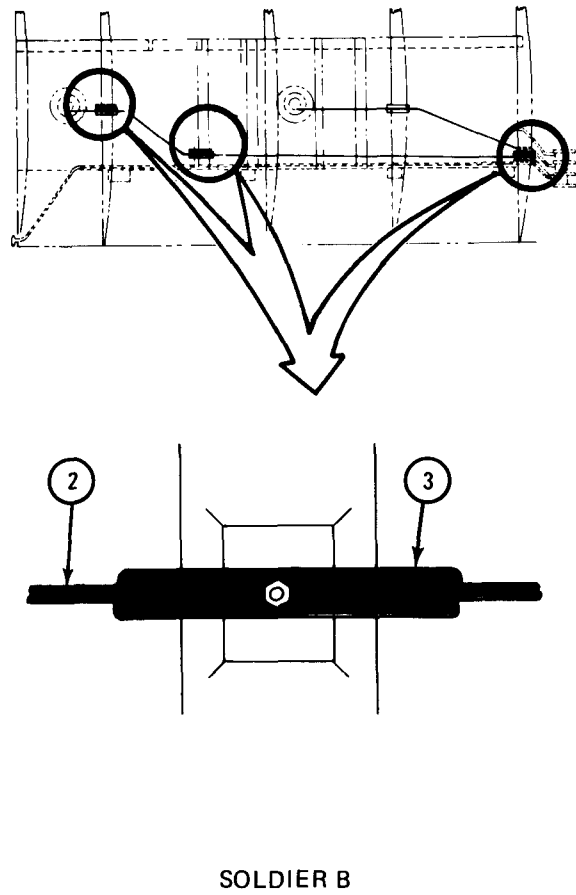
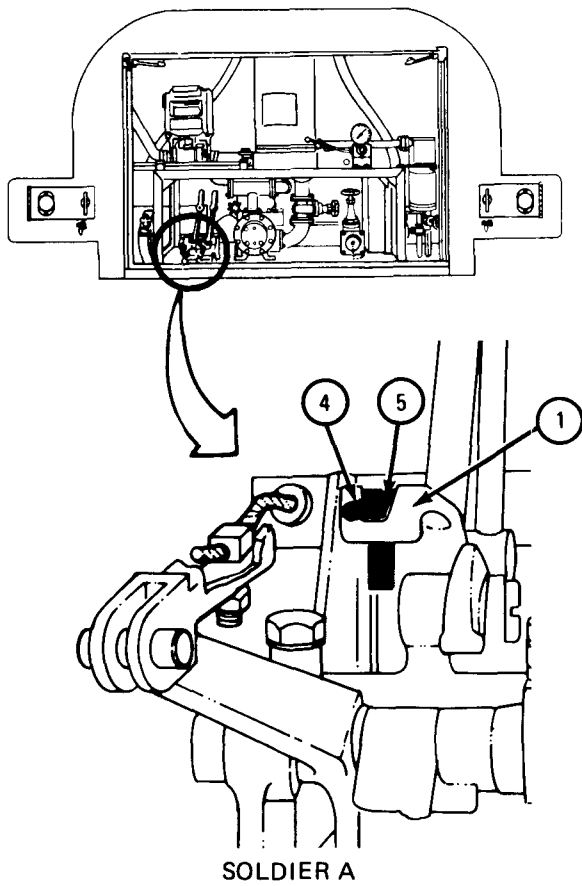

TA 046579

FRAME 3

1. Using pliers, pull most of the slack out of cable (1).
2. Using 1/2-inch wrench, screw on and tighten nut (2).
3. Close truck rear compartment doors.

NOTE

Follow-on Maintenance Action Required:  
Lubricate tubes. Refer to LO 9-2320-209-12/1.

END OF TASK

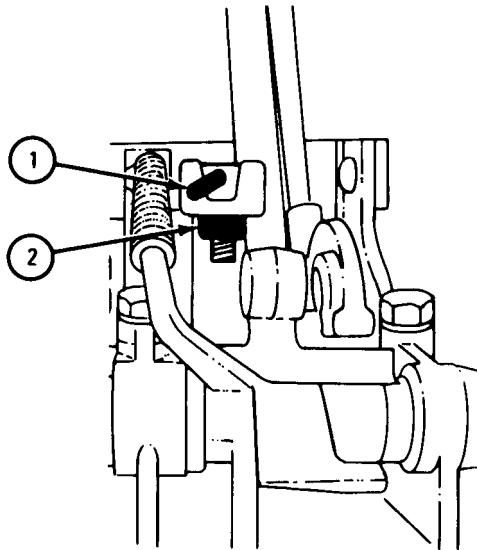

TA 046580

18-27. INTERMEDIATE DISCHARGE VALVE CABLE REMOVAL AND REPLACEMENT  
(TRUCK M49A1C).

TOOLS: 1/2-inch wrench  
5/8-inch wrench (2)  
Leather gloves

SUPPLIES: None

PERSONNEL: Two

EQUIPMENT CONDITION: Truck parked, engine off, handbrake set, wheels chocked.

WARNING

Smoking, sparks or open flame are not allowed within 50 feet of fuel truck during this task. Fuel may burn, causing explosion, injury to personnel, and damage to equipment.

Always wear protective gloves when handling cable. Do not let cable slip through hands. Rusty or broken wires can cause injury.

a. Removal.

FRAME 1

1. Open truck rear compartment doors.
2. Using 1/2-inch wrench, unscrew and take off nut (1). Take cable (2) out of special bolt (3).

GO TO FRAME 2

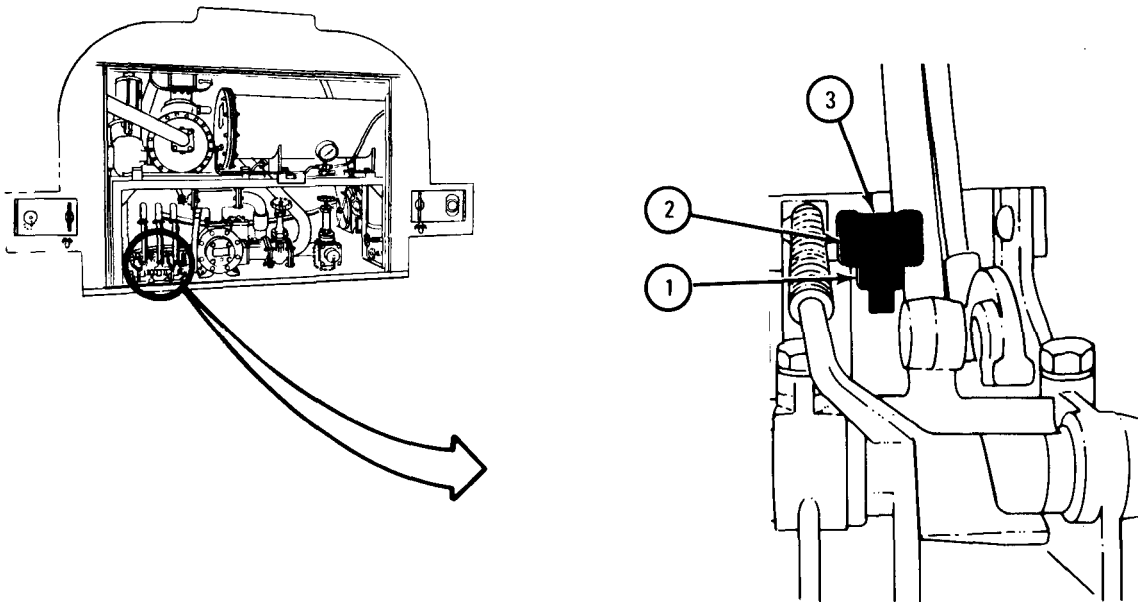

TA 046571

FRAME 2

1. Using 5/8-inch wrench, hold split screw (1). Using 5/8-inch wrench, unscrew and take off nut (2) from split screw. Take off both parts of split screw.
2. Take cable end (3) out of nut (2) and valve lever (4). Take off nut from cable (5).
3. Cable (5) is now free on both ends. Take cable out of truck.

END OF TASK

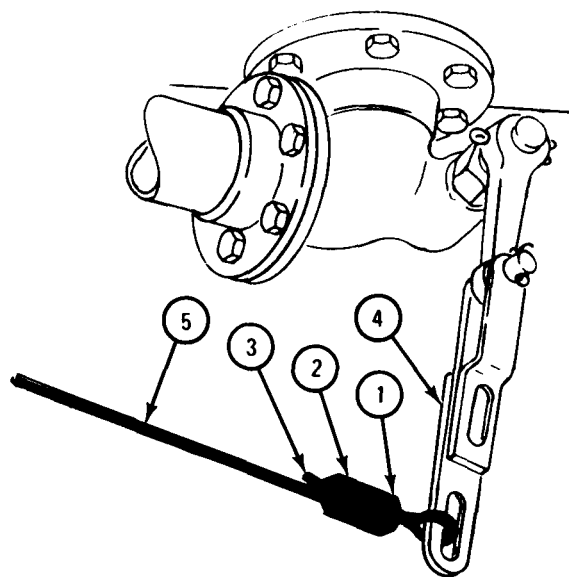
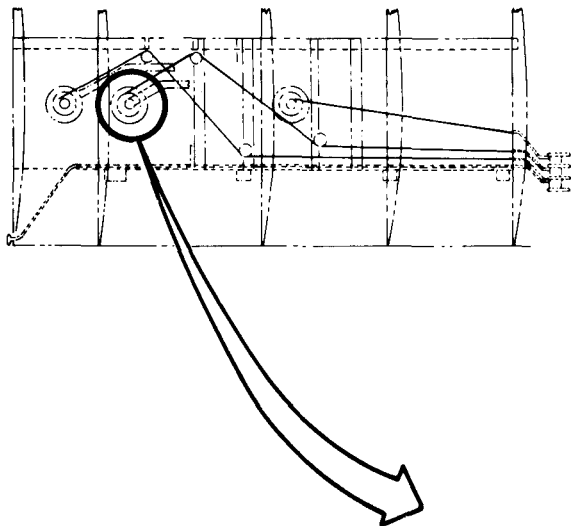

TA 046572



b. Replacement.

## FRAME 1

1. Put cable (1) through nut (2). Put cable through hole in valve lever (3) and back through nut, leaving a loose loop at valve lever. Let about 1/2 inch of cable end come out of nut.
2. Put two halves of split screw (4) together around both parts of cable (1) and screw on nut (2).
3. Using 5/8-inch wrench, hold split screw (4). Using 5/8-inch wrench, tighten nut (2).

GO TO FRAME 2

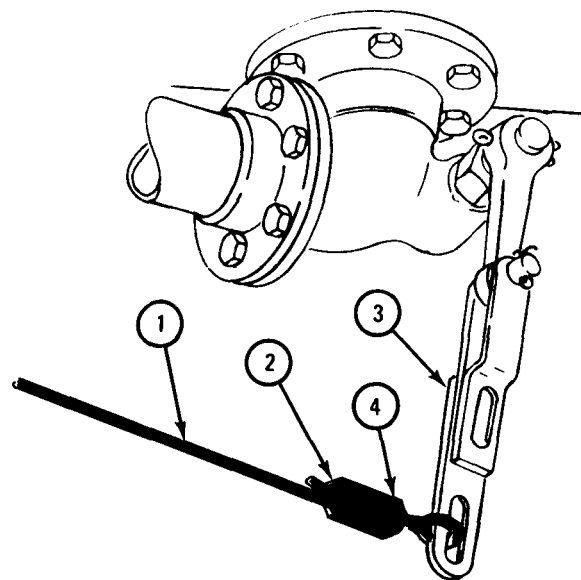
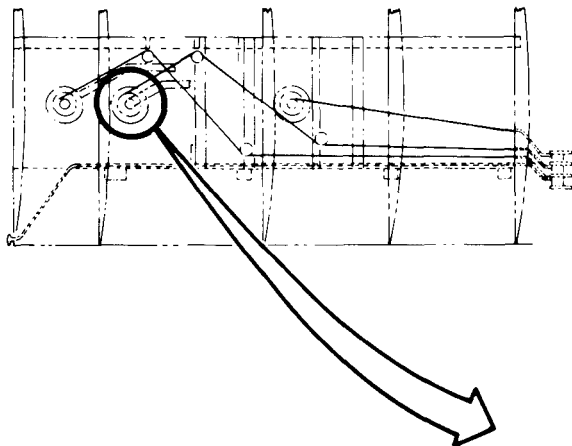

TA 046573

FRAME 2

Soldier A 1. Working from front to back of truck, put cable (1) through two sheaves (2). Make sure cable is routed as shown and that it will not rub on any truck parts.

Soldier B 2. Put discharge lever (3) for intermediate discharge valve in the closed position. Refer to TM 9-2320-209-10.

GO TO FRAME 3

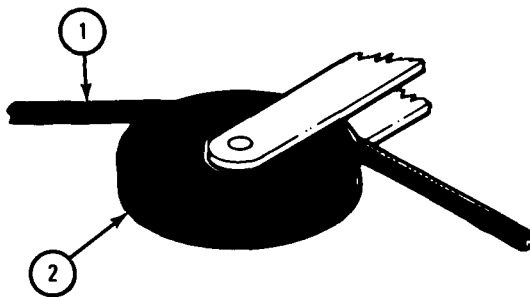
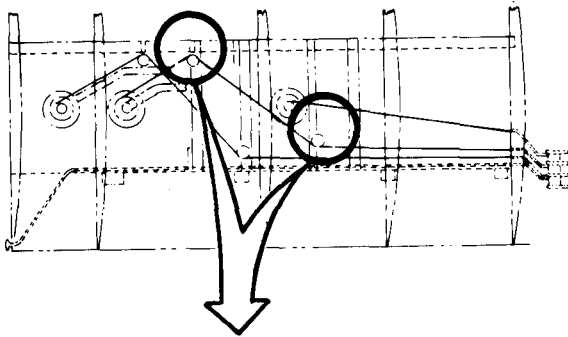

SOLDIER A

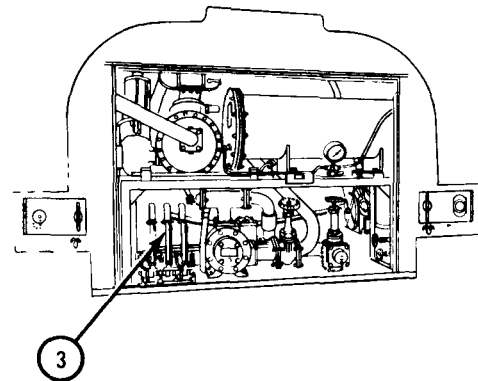

SOLDIER B

TA 046574

FRAME 3

- Soldier A 1. Put cable (1) through tube (2) and tell soldier B to take end of cable.
- Soldier B 2. Using pliers, put cable end (3) through hole in special bolt (4).
3. Put special bolt (4) in arm (5). Pull cable end (3) to take out most of the slack. Using 1/2-inch wrench, screw on and tighten nut (6).
4. Close truck rear compartment doors.

NOTE

Follow-on Maintenance Action Required:  
Lubricate cable. Refer to LO 9-2320-209-12/1.

END OF TASK

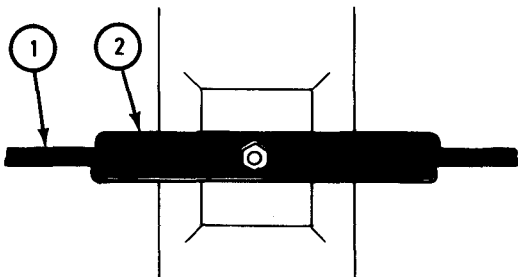
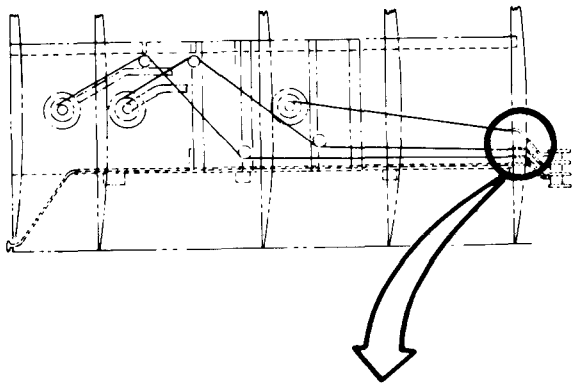

SOLDIER A

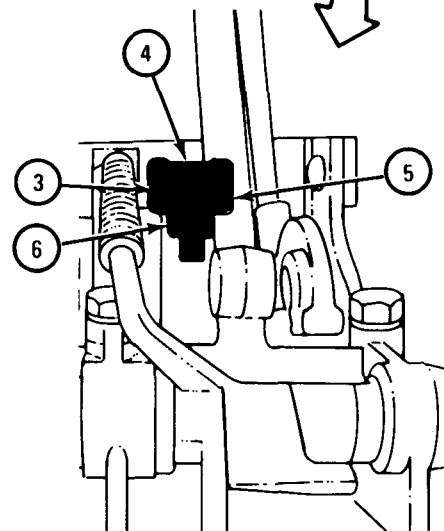
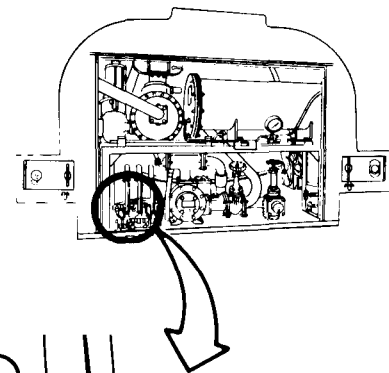

SOLDIER B

TA 046575

18-28. REAR DISCHARGE VALVE CABLE REMOVAL AND REPLACEMENT (TRUCK M49A1C).

TOOLS: 1/2-inch wrench  
5/8-inch wrench (2)  
Leather gloves  
Pliers

SUPPLIES: None

PERSONNEL: Two

EQUIPMENT CONDITION: Truck parked, engine off, handbrake set, wheels chocked.

WARNING

Smoking, sparks or open flame are not allowed within 50 feet of fuel truck during this task. Fuel may burn, causing explosion, injury to personnel, and damage to equipment.

Always wear protective gloves when handling cable. Do not let cable slip through hands. Rusty or broken wires can cause injury.

a. Removal.

FRAME 1

1. Open truck rear compartment doors.
2. Using 1/2-inch wrench, unscrew and take off nut (1). Take cable (2) out of special bolt (3).

GO TO FRAME 2

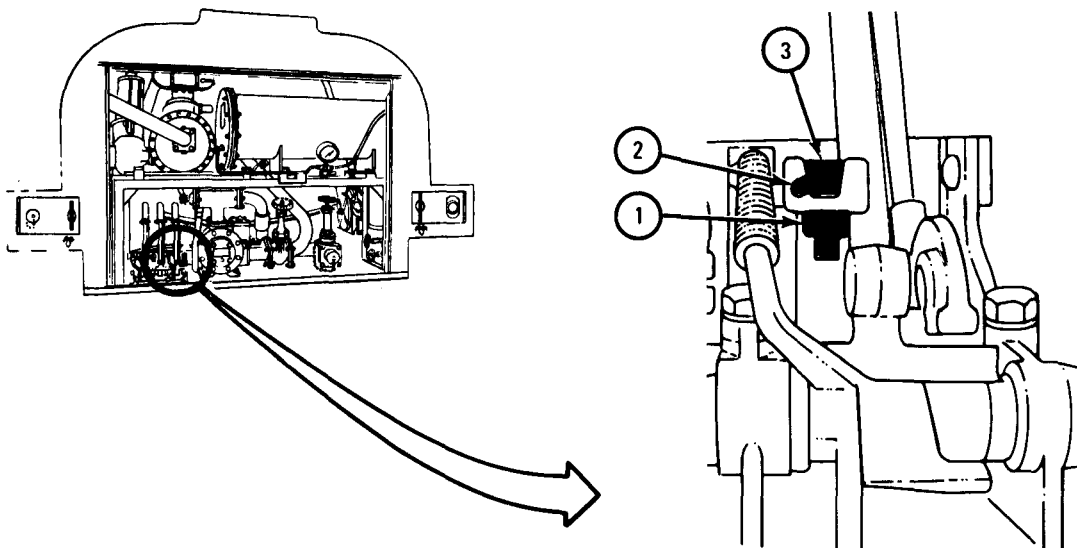

TA 046567

## FRAME 2

1. Using 5/8-inch wrench, hold split screw (1). Using 5/8-inch wrench, unscrew and take off nut (2) from split screw. Take off both parts of split screw.
2. Take cable end (3) out of nut (2) and valve lever (4). Take off nut from cable (5).
3. Cable (5) is now free on both ends. Take cable out of truck.

END OF TASK

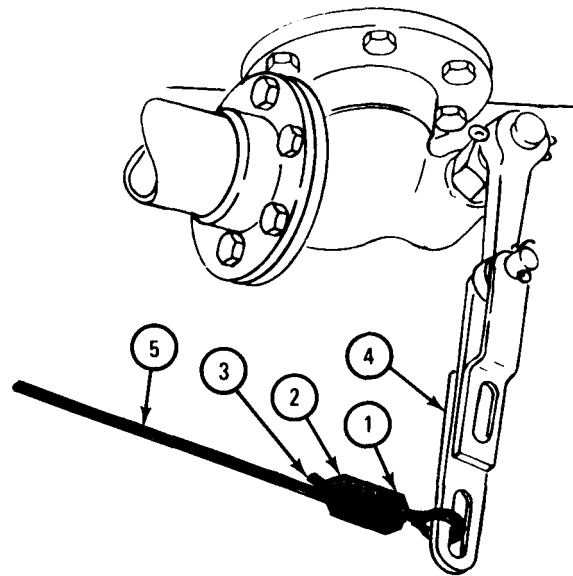
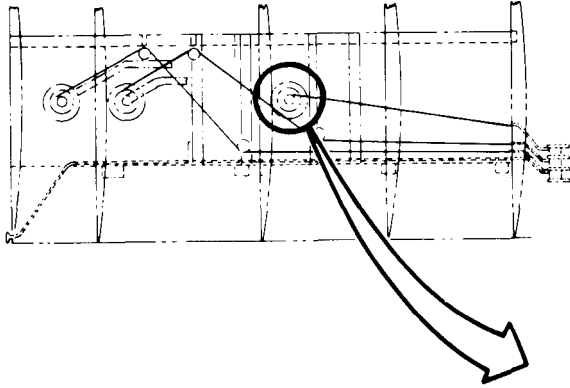

TA 046568

b. Replacement.

FRAME 1

1. Put cable (1) through nut (2). Put cable through hole in valve lever (3) and back through nut, leaving a loose loop at valve lever. Let about 1/2 inch of cable end come out of nut.
2. Put two halves of split screw (4) together around both parts of cable (1) and screw on nut (2).
3. Using 5/8-inch wrench, hold split screw (4). Using 5/8-inch wrench, tighten nut (2).

GO TO FRAME 2

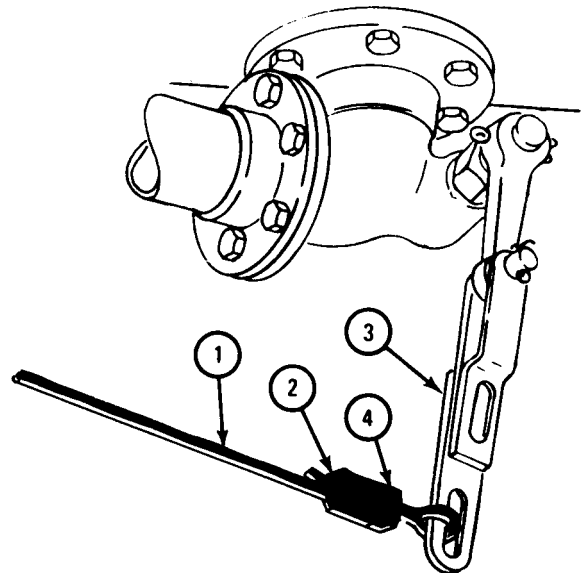
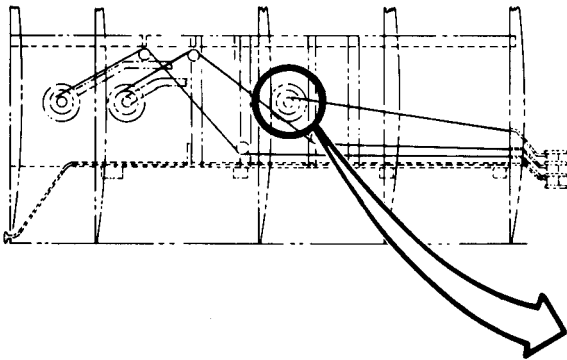

TA 046569

FRAME 2

- Soldier A 1. Put discharge lever (1) for rear discharge valve in the closed position. Refer to TM 9-2320-209-10.
- Soldier B 2. Put cable (2) through tube (3) and tell soldier A to take end of cable.
- Soldier A 3. Using pliers, put cable end (4) through hole in special bolt (5).
4. Put special bolt (5) in arm (6). Pull cable end (4) to take out most of the slack. Using 1/2-inch wrench, screw on and tighten nut (7).
5. Close truck rear compartment doors.

NOTE

Follow-on Maintenance Action Required:  
Lubricate cable. Refer to LO-2320-209-12/1.

END OF TASK

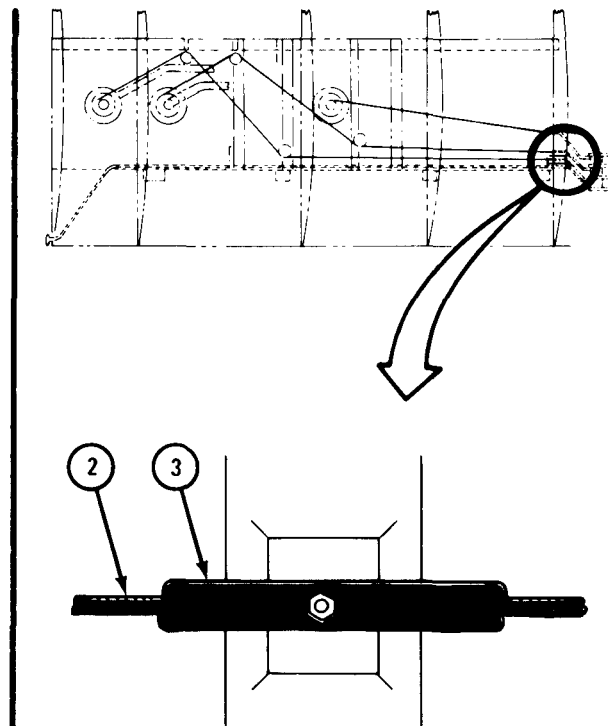
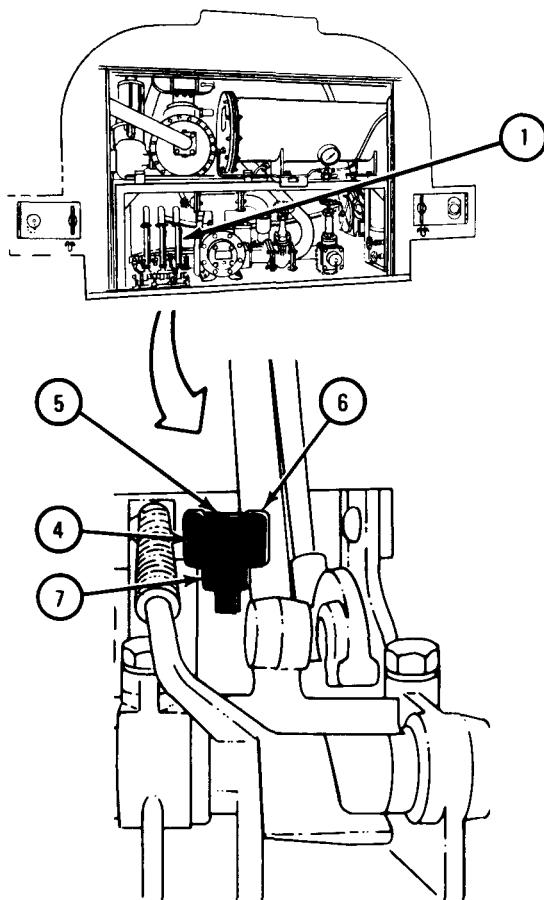

TA 046570

18-29. REAR DISCHARGE VALVE CABLE REMOVAL AND REPLACEMENT (TRUCK M49A2C).

TOOLS: 1/2-inch wrench  
7/16-inch wrench  
Leather gloves  
Pliers

SUPPLIES: None

PERSONNEL: Two

EQUIPMENT CONDITION: Truck parked, engine off, handbrake set, wheels chocked.

WARNING

Smoking, sparks or open flame are not allowed within 50 feet of fuel truck during this task. Fuel may burn, causing explosion, injury to personnel, and damage to equipment.

Always wear protective gloves when handling cable. Do not let cable slip through hands. Rusty or broken wires can cause injury.

a. Removal.

FRAME 1

1. Open truck rear compartment doors.
2. Using 1/2-inch wrench, loosen nut (1). Take cable (2) out of special bolt (3).

GO TO FRAME 2

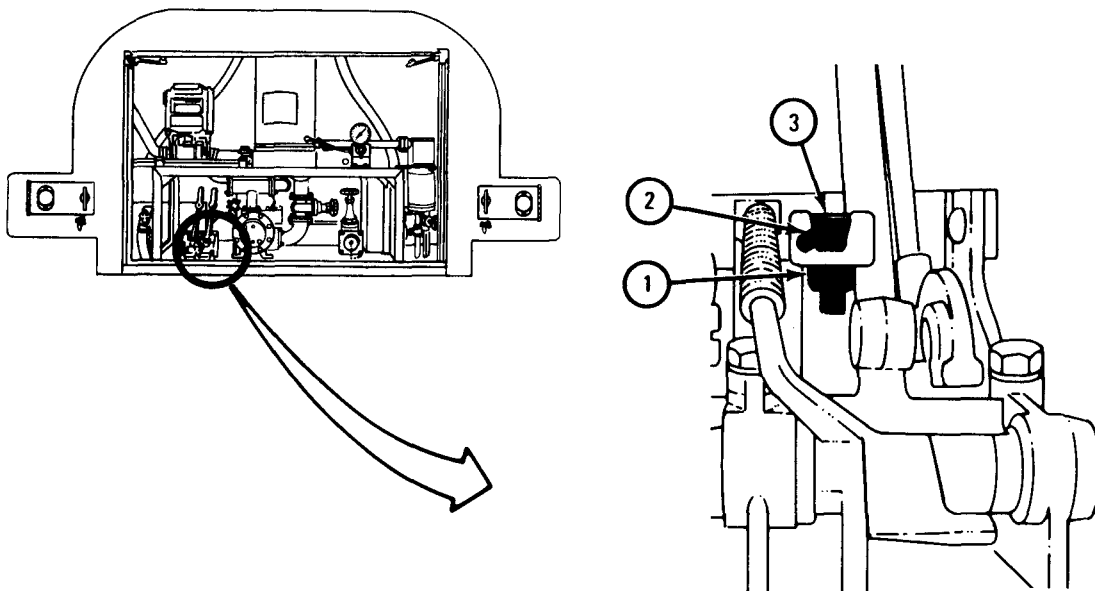

TA 046581



## FRAME 2

1. Working under center of tank and using 1/16-inch wrench, unscrew and take off two nuts (1). Take off plate (2) and U-bolt (3). Cable (4) will be free of valve lever (5).
2. Cable (4) is now free on both ends. Take cable out of truck.

END OF TASK

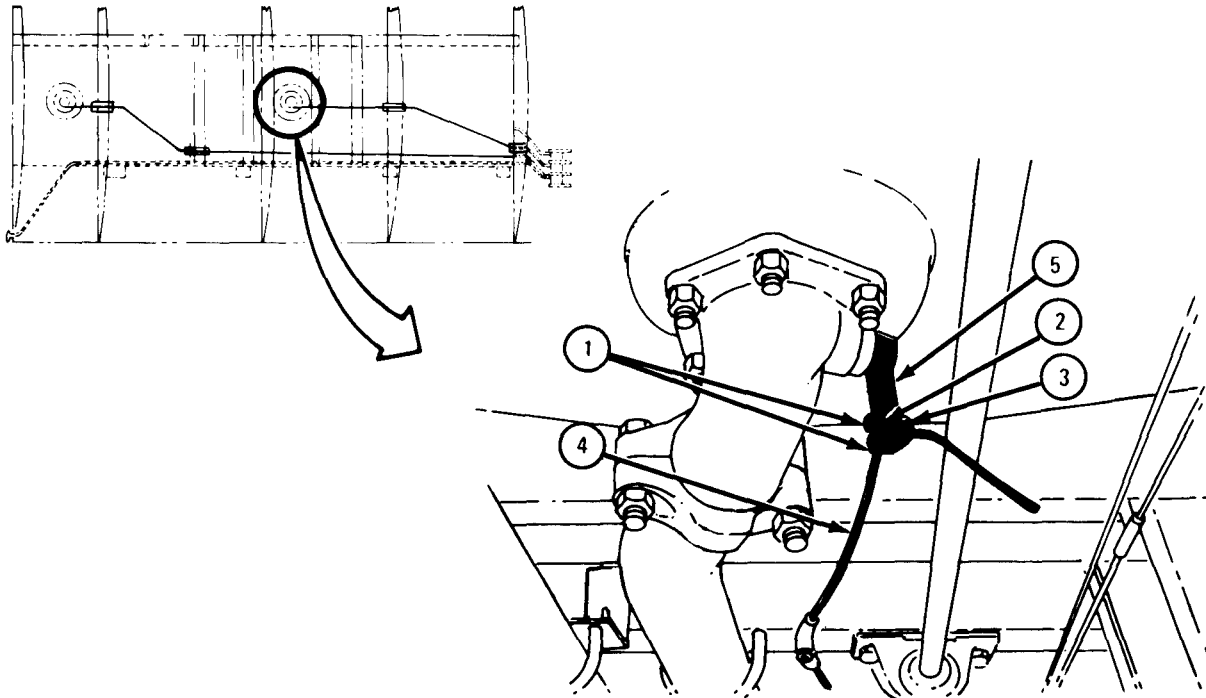

TA 046582

b. Replacement.

FRAME 1

1. Put cable (1) to valve lever (2) so it will be held by U-bolt (3). Put U-bolt through holes in valve lever.
2. Put plate (4) on U-bolt (3). Screw on two nuts (5) to U-bolt.
3. Using 7/16-inch wrench, tighten two nuts (5).

GO TO FRAME 2

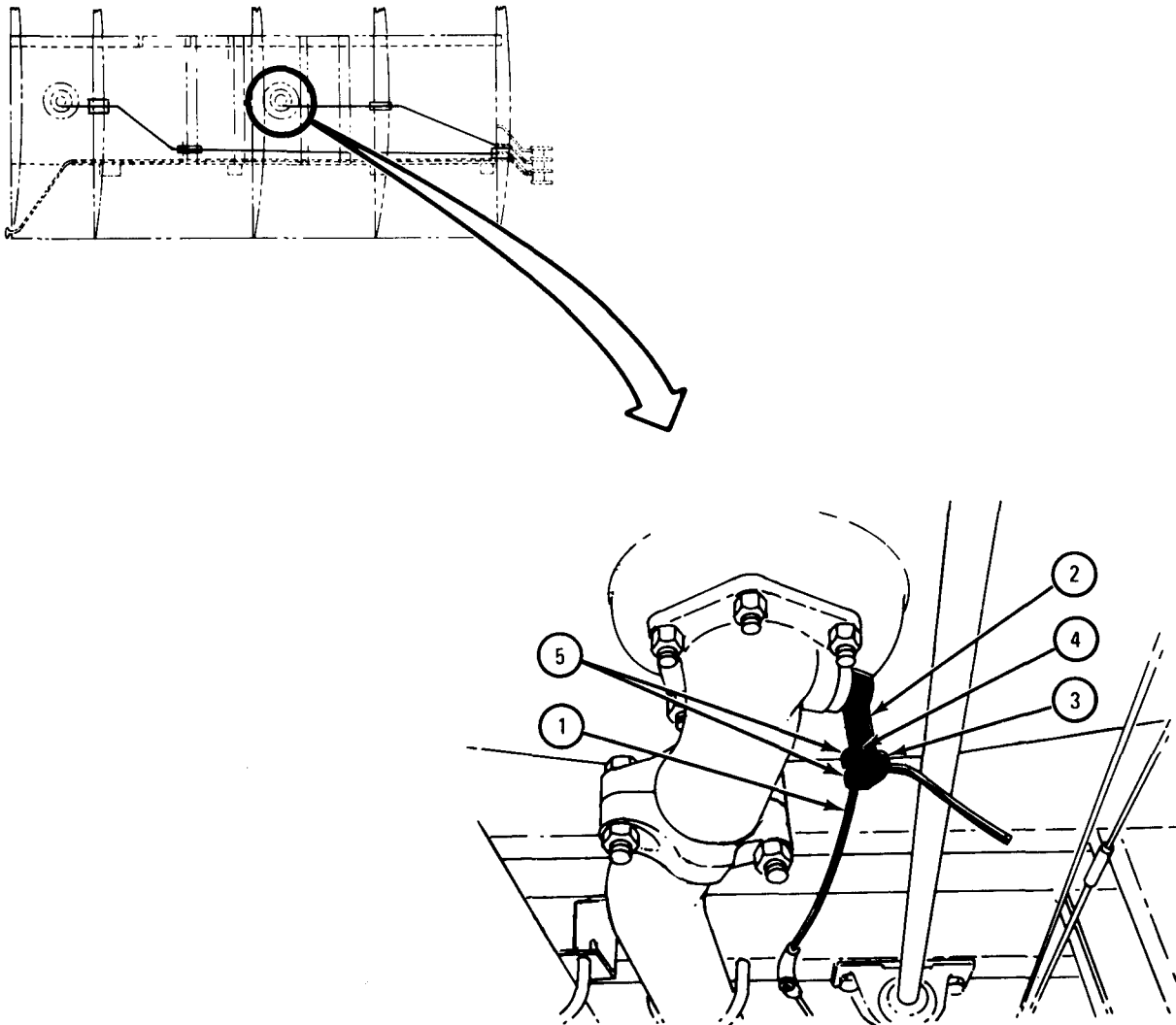

TA 046583

FRAME 2

- Soldier A 1. Put discharge lever (1) for rear discharge valve in the closed position. Refer to TM 9-2320-209-10.
- Soldier B 2. Working from front to back of truck, put cable (2) through two tubes (3). When you have cable through both tubes, tell soldier A to take end of cable.
- Soldier A 3. Using pliers, put cable end (4) through hole in special bolt (5). Using pliers, hold cable so it does not come out of special bolt.
- GO TO FRAME 3

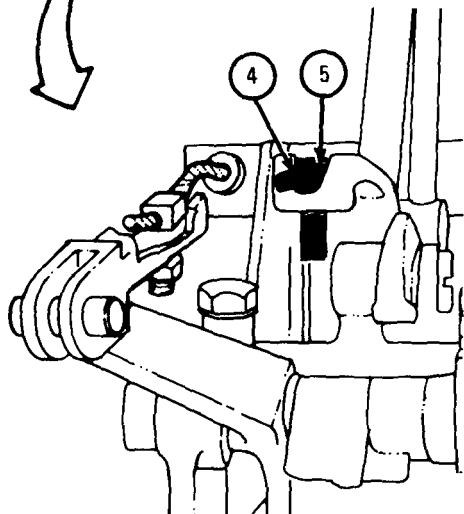
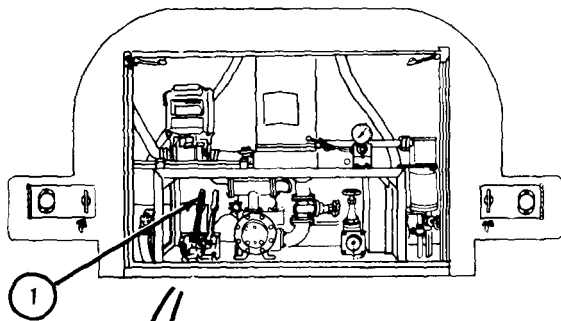

SOLDIER A

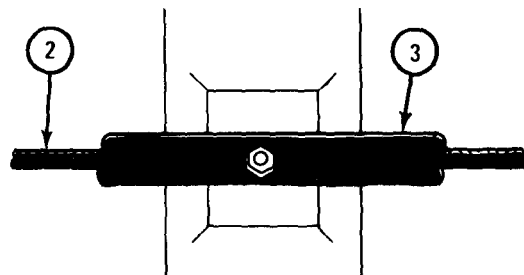
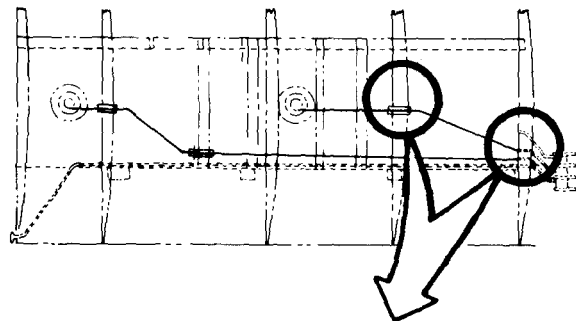

SOLDIER B

TA 046584

FRAME 3

1. Using pliers, pull most of the slack out of cable (1).
2. Using 1/2-inch wrench, screw on and tighten nut (2).
3. Close truck rear compartment doors.

NOTE

Follow-on Maintenance Action Required:  
Lubricate tubes. Refer to LO 9-2320-209-12/1.

END OF TASK

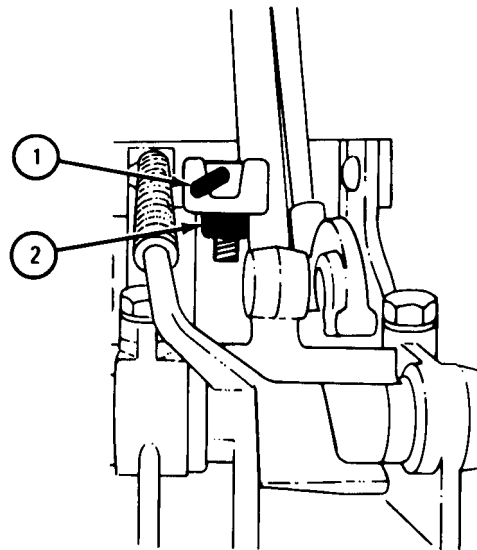

TA 046580

## 18-30. FUSIBLE LINK REMOVAL AND REPLACEMENT.

WARNING

Smoking, sparks or open flame are not allowed within 50 feet of fuel truck during this task. Fuel may burn, causing explosion, injury to personnel, and damage to equipment.

TOOLS: Long nose pliers

SUPPLIES: None

PERSONNEL: One

EQUIPMENT CONDITION: Truck parked, engine off, handbrake set.

a. Removal.

## FRAME 1

1. Using pliers, unhook end of emergency release control spring (1) from hole in lever (2).
2. Using pliers, unhook end of fusible link release spring (3) from hole in lever (4).
3. Using pliers, take cotter pin (5) out of shaft (6). Throw cotter pin away.
4. Take fusible link (7) off shaft (6).

GO TO FRAME 2

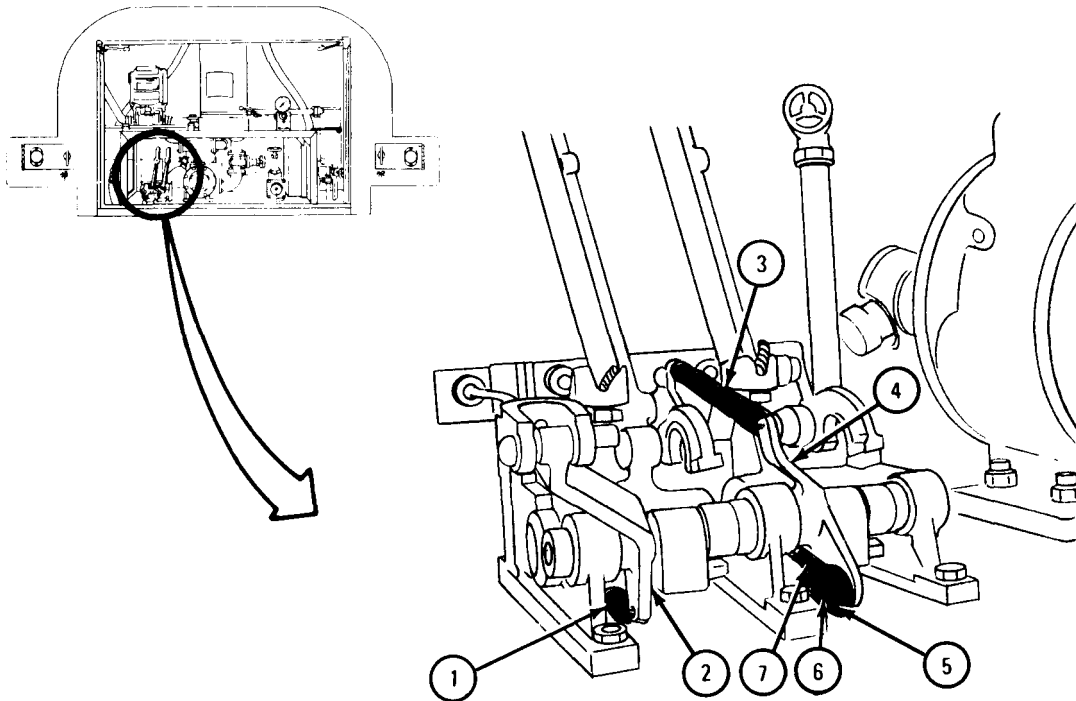

TA 046585

FRAME 2

1. Lift up lever (1) so it is out of the way.
2. Using pliers, take cotter pin (2) out of shaft (3). Throw away cotter pin.
3. Take fusible link (4) off shaft (3).

END OF TASK

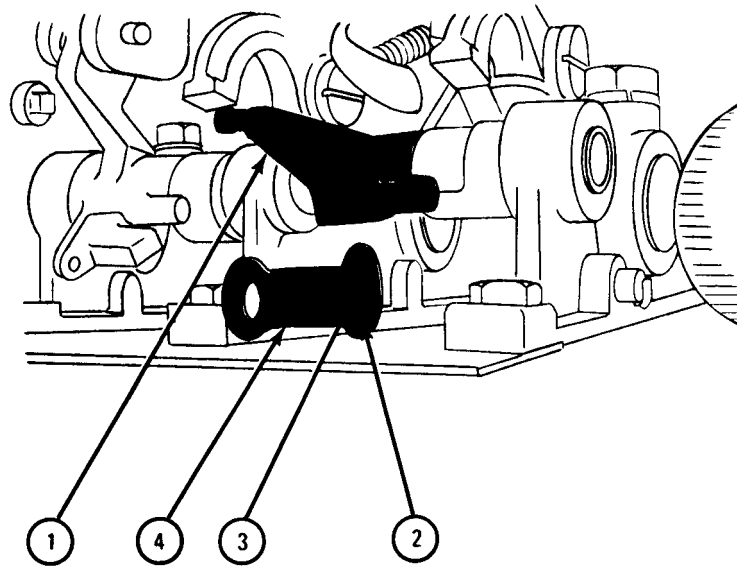

TA 046586

b. Replacement.

## FRAME 1

1. Put fusible link (1) onto shaft (2).
2. Put cotter pin (3) in hole in shaft (2). Using pliers, bend open ends of cotter pin.

GO TO FRAME 2

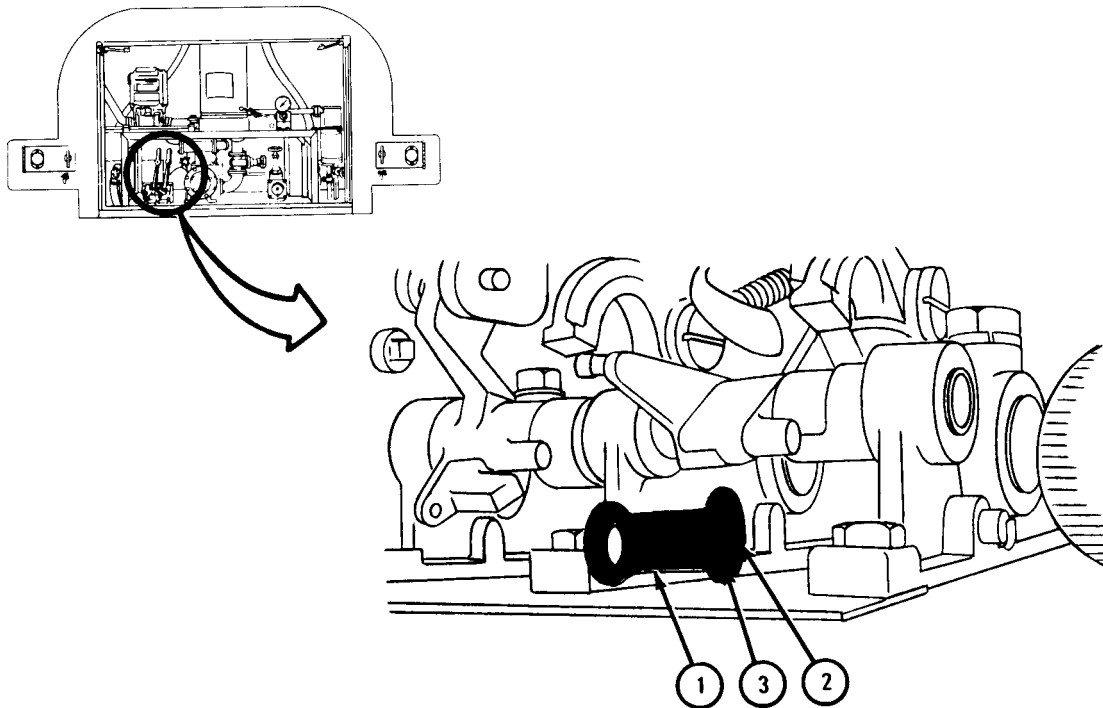

TA 046587

FRAME 2

1. Push lever (1) down so shaft (2) and fusible link (3) line up. Put fusible link on shaft.
2. Put cotter pin (4) through hole in shaft (2). Using pliers, bend open ends of cotter pin.
3. Using pliers, hook fusible link release spring (5) in hole in lever (1).
4. Using pliers, hook emergency release control spring (6) in hole in lever (7).

END OF TASK

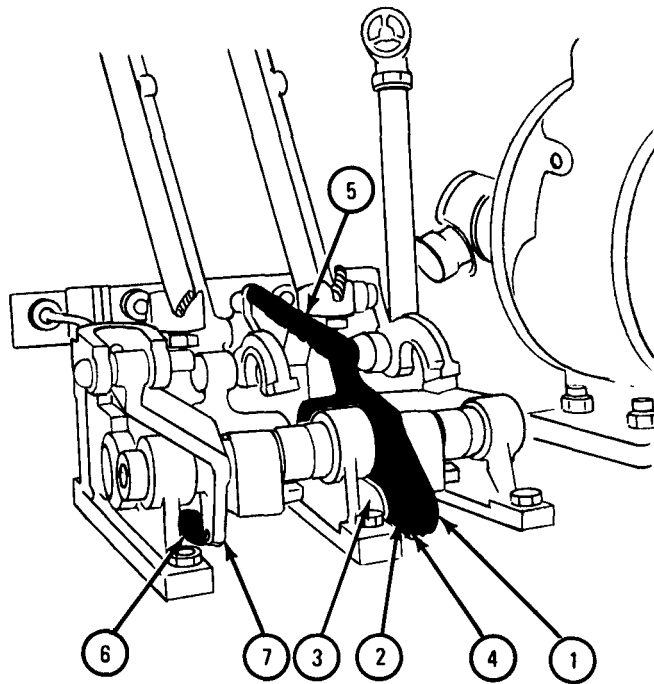

TA 046588



## 18-31. GLOVE VALVE REMOVAL AND REPLACEMENT.

TOOLS: Pipe wrench (2)  
7/8-inch wrench

SUPPLIES: 5-gallon container

PERSONNEL: One

EQUIPMENT CONDITION: Truck parked, engine off, handbrake set.

WARNING

Smoking, sparks or open flame are not allowed within 50 feet of working area during this task. Fuel may burn, causing explosion, injury to personnel, and damage to equipment.

a. Removal.

FRAME 1

1. Open fuel truck rear compartment doors.
2. Put container under fuel drain line (1) so it catches draining fuel. Turn globe valve handle (2) to the left.

IF WORKING ON TRUCK M49A1C, GO TO FRAME 2.

IF WORKING ON TRUCK M49A2C, GO TO FRAME 3

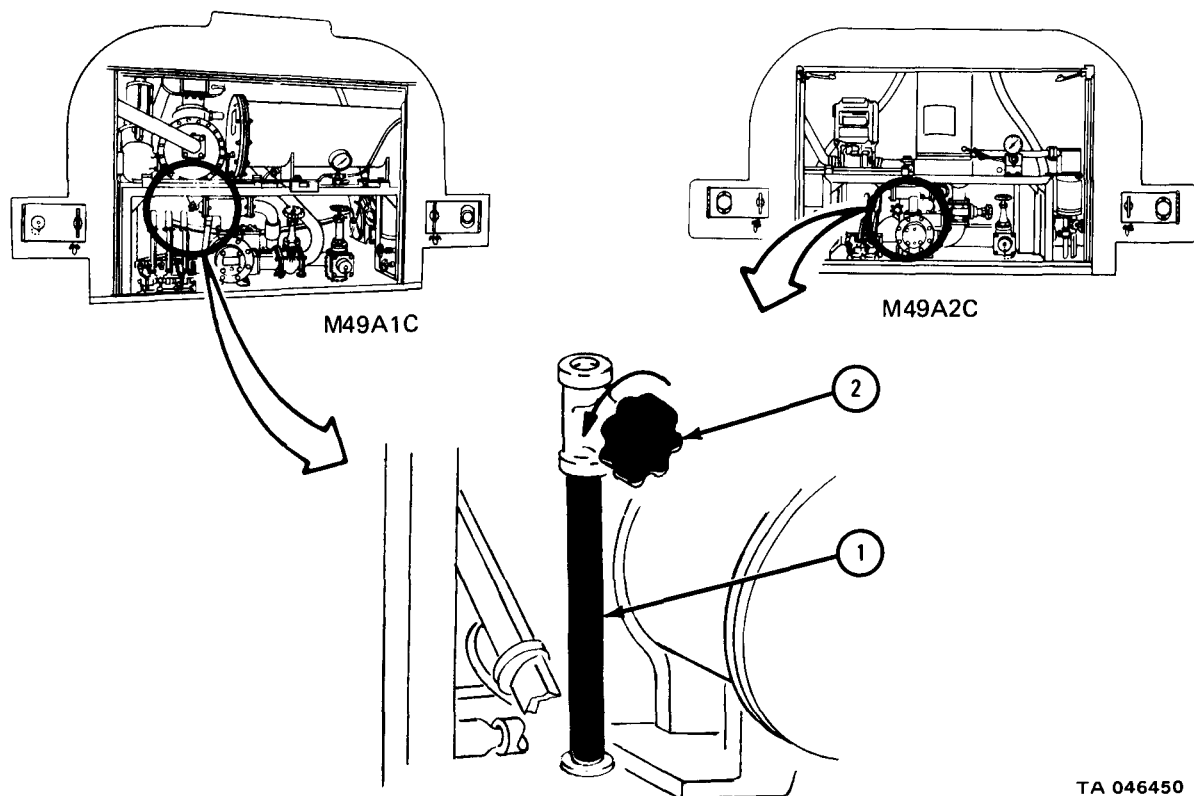

TA 046450

FRAME 2

1. Turn valve (1) all the way to right to close.
2. Pull lever (2) all the way back.
3. Using pipe wrenches, hold globe valve (3) and unscrew and take off pipe (4).
4. Using pipe wrenches, hold pipe (5) and unscrew and take off globe valve (3).

END OF TASK

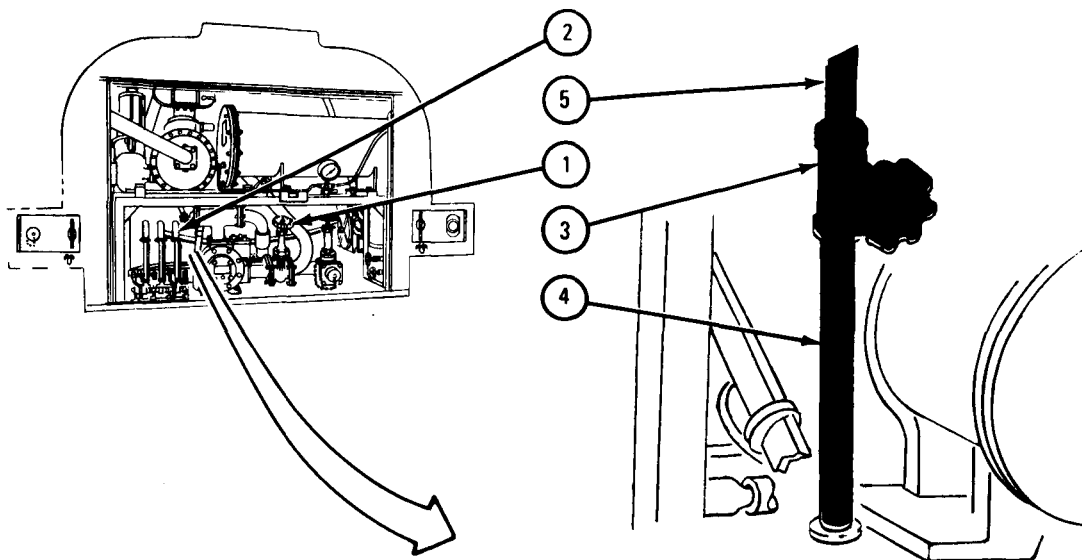

TA 046451

## FRAME 3

1. Using pipe wrenches, hold globe valve (1) and unscrew and take off pipe (2).
2. Using 7/8-inch wrench and pipe wrench, hold fitting (3) and unscrew and take off globe valve (1).

END OF TASK

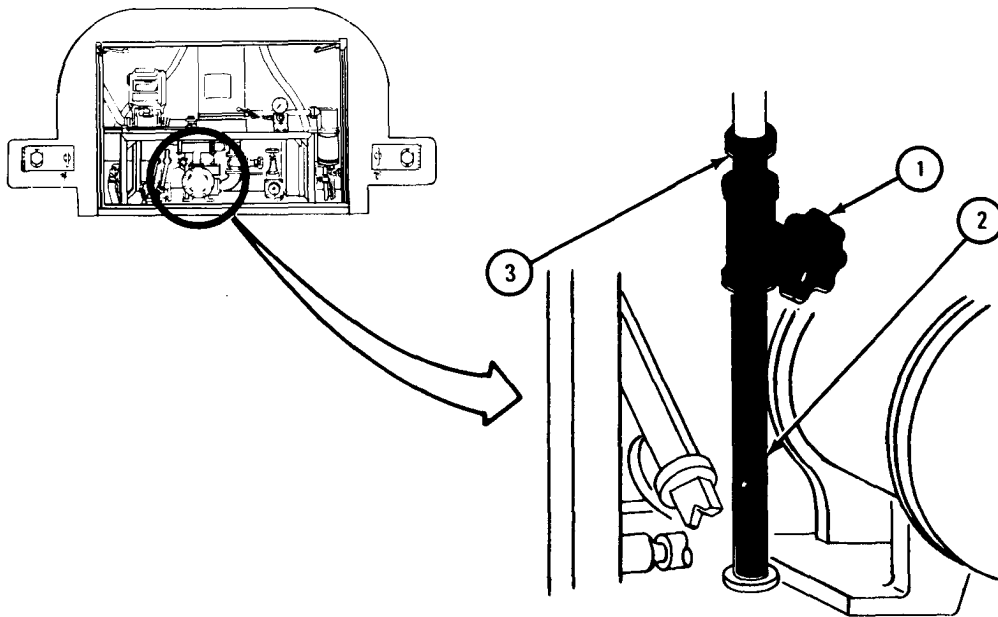

TA 101562

b. Replacement.

NOTE

If working on truck M49A1C, do frame 1.  
If working on truck M49A2C, do frame 2.

FRAME 1

1. Using pipe wrenches, hold pipe (1) and screw on and tighten globe valve (2) so handle (3) faces back of truck.
2. Using pipe wrenches, hold globe valve (2) and screw on and tighten pipe (4).
3. Push discharge valve control lever (5) forward to close.
4. Close fuel truck rear compartment doors.

END OF TASK

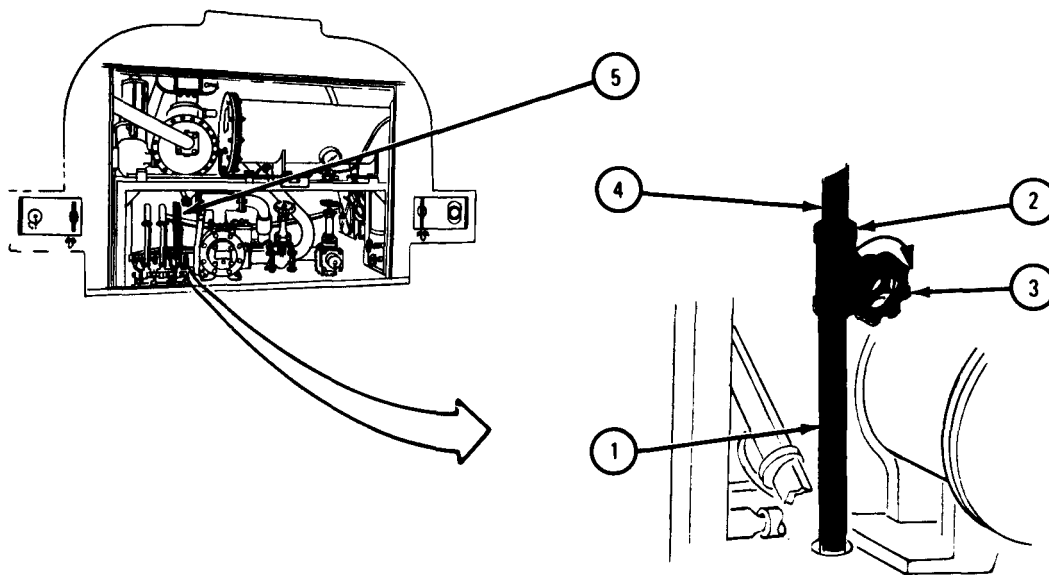

TA 046452

## FRAME 2

1. Using 7/8-inch wrench and pipe wrench, hold fitting (1) and screw on and tighten globe valve (2) so handle (3) faces back of truck.
2. Using pipe wrenches, hold globe valve (2) and screw on and tighten pipe (4).
3. Close fuel truck rear compartment doors.

END OF TASK

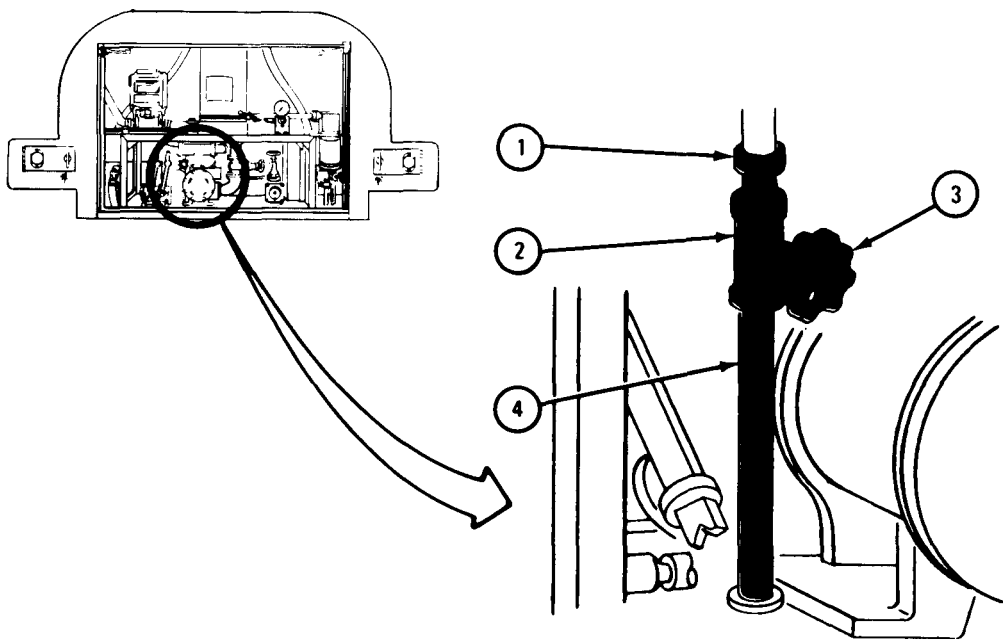

TA 101563

18-32. DISCHARGE VALVE OPERATING LEVER REMOVAL AND REPLACEMENT.

NOTE

Truck M49A1C has three discharge valve operating levers. Truck M49A2C has two discharge valve operating levers. This task is the same for both trucks, but details are shown for truck M49A1C.

TOOLS: 3/4-inch open end wrench  
 1/2-inch open end wrench  
 7/16-inch open end wrench (2)  
 Pliers  
 Leather gloves

SUPPLIES: None

PERSONNEL: One

EQUIPMENT CONDITION: Truck parked, engine off, handbrake set.

WARNING

Smoking, sparks, or open flame are not allowed within 50 feet of fuel truck during this task. Fuel may burn, causing explosion, injury to personnel, and damage to equipment.

Always wear protective gloves when handling cable. Do not let cable slip through hands. Rusty or broken wires can cause injury.

a. Removal.

FRAME 1

1. Open truck rear compartment doors.
2. Using 1/2-inch wrench, unscrew and take off four nuts (1). Take four cables (2) out of four special bolts (3).

GO TO FRAME 2

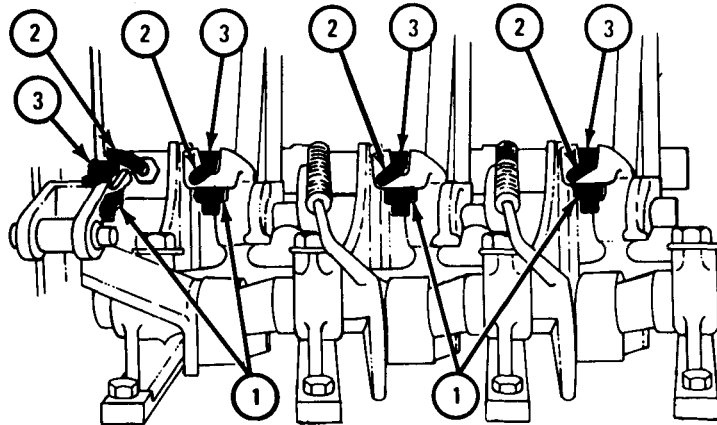
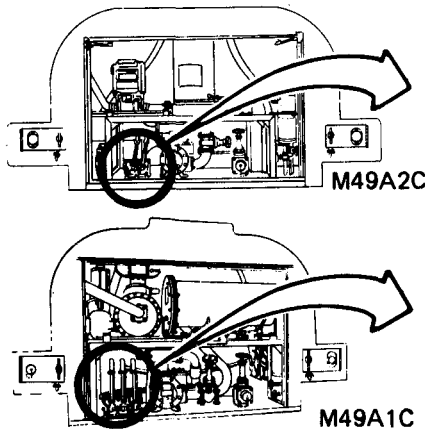

TA 046591

## FRAME 2

1. Using 3/4-inch wrench, unscrew four coupling nuts (1). Slide coupling nuts back onto tubes (2).
2. Using 7/16-inch wrenches, unscrew and take out eight nuts (3) and eight bolts (4).
3. Take out discharge valve operating lever (5).

END OF TASK

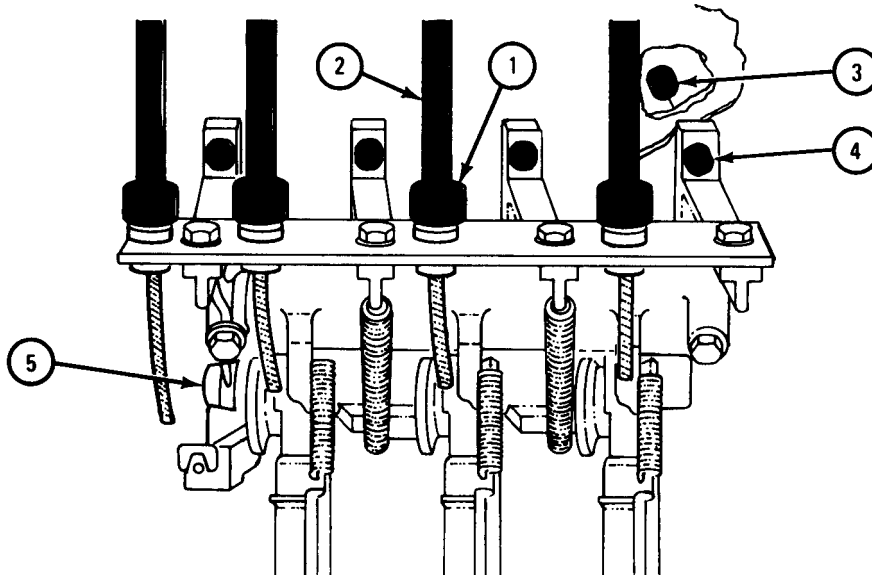

TA 046592

b. Replacement.

FRAME 1

1. Put discharge valve operating lever (1) in place, feeding four cables (2) through guides (3).
2. Using 7/16-inch wrenches, screw in and tighten eight bolts (4) and eight nuts (5).
3. Using 3/4-inch wrench, screw on and tighten four coupling nuts (6).

GO TO FRAME 2

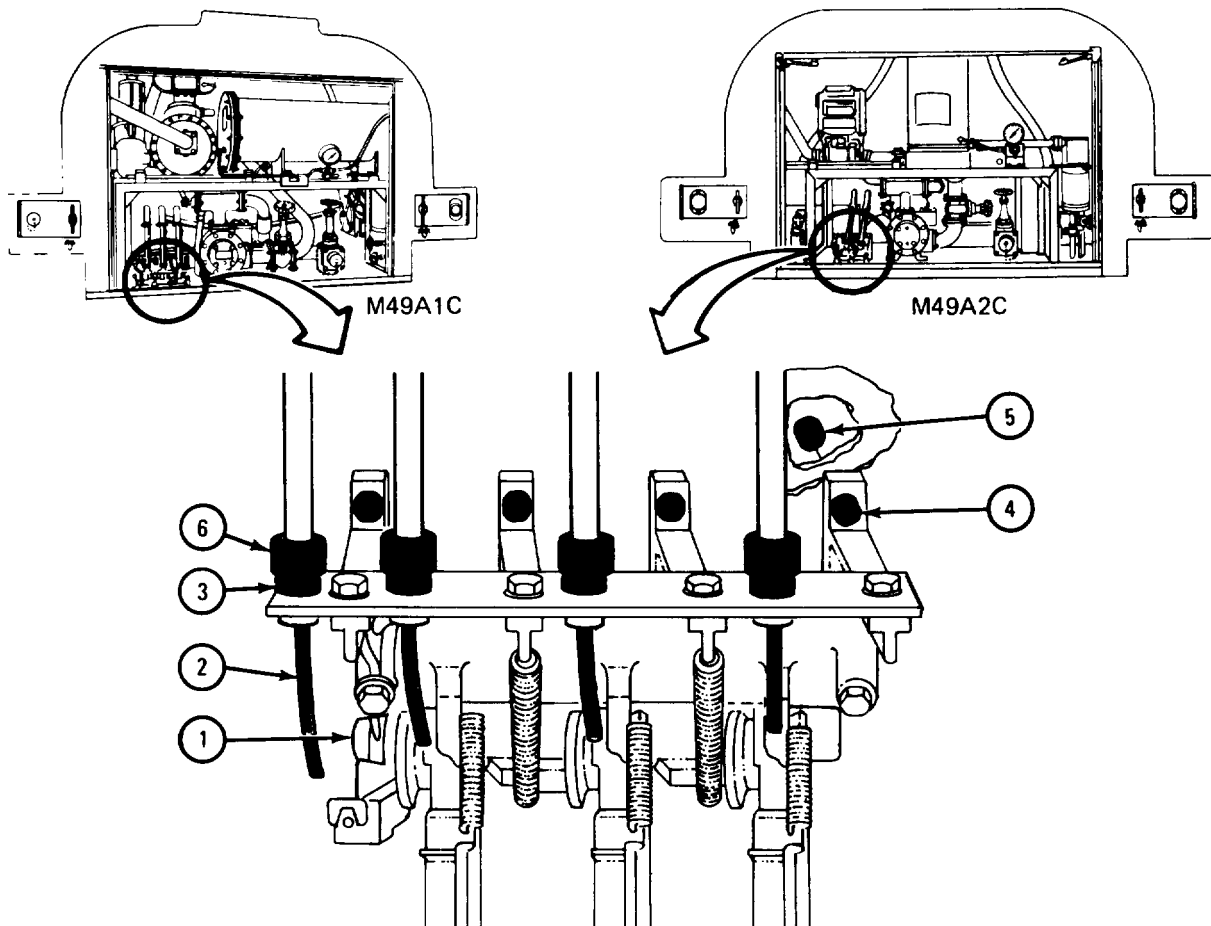

TA 046593



## FRAME 2

1. Using pliers, put four cable ends (1) through holes in special bolts (2). Using pliers, pull cable ends to take out most of the slack. Using 1/2-inch wrench, screw on and tighten four nuts (3).
2. Close truck rear compartment doors.

END OF TASK

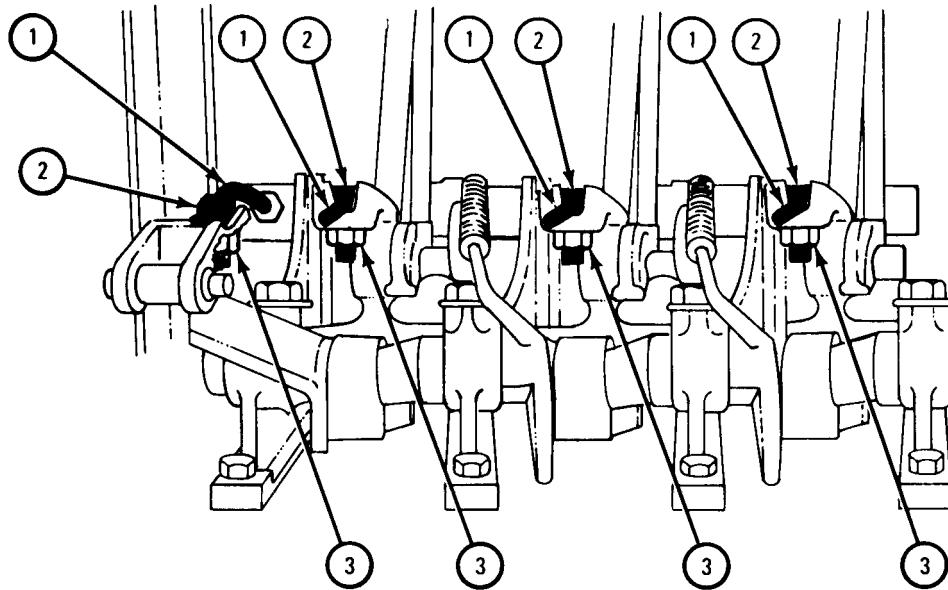

TA 046594

18-33. CENTRIFUGAL PUMP REMOVAL AND REPLACEMENT (TRUCKS M49A1C AND M49A2C).

TOOLS: 9/16-inch wrench (2)  
3/4-inch wrench  
3/16-inch sockethead screw key (Allen wrencher equivalent)  
Mallet  
Flat-tip screwdriver

SUPPLIES: Elbow inlet tube gasket  
Outlet tube gasket

PERSONNEL: One

EQUIPMENT CONDITION: Truck parked, engine off, handbrake set.

WARNING

Smoking, sparks or open flame are not allowed within 50 feet of fuel truck during this task. Fuel may burn, causing explosion, injury to personnel, and damage to equipment.

a. Removal.

FRAME 1

1. Open fuel truck rear compartment doors.
2. Using allen wrench, loosen setscrew (1) in yoke (2).

GO TO FRAME 2

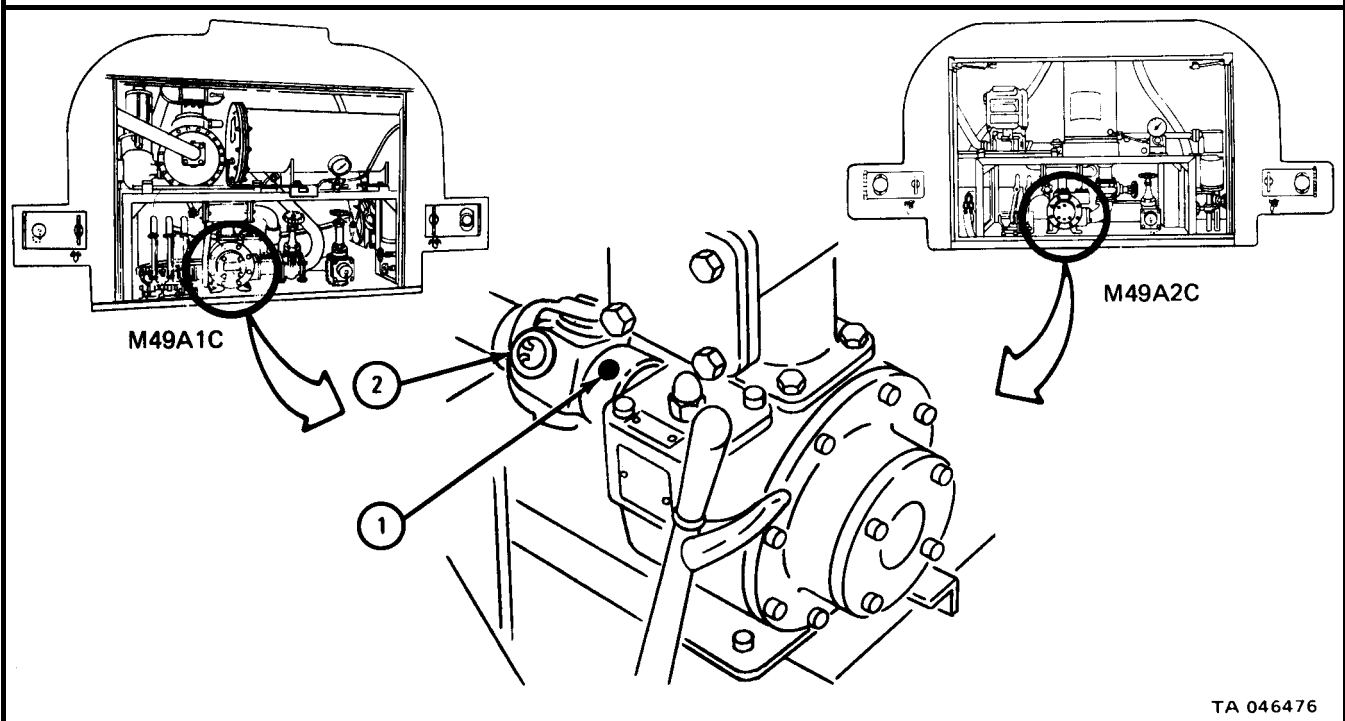

TA 046476

## FRAME 2

1. Using 9/16-inch wrench, unscrew and takeout four screws (1) with lockwashers (2).
2. Take off outlet tube gasket (3) and throw it away.

GO TO FRAME 3

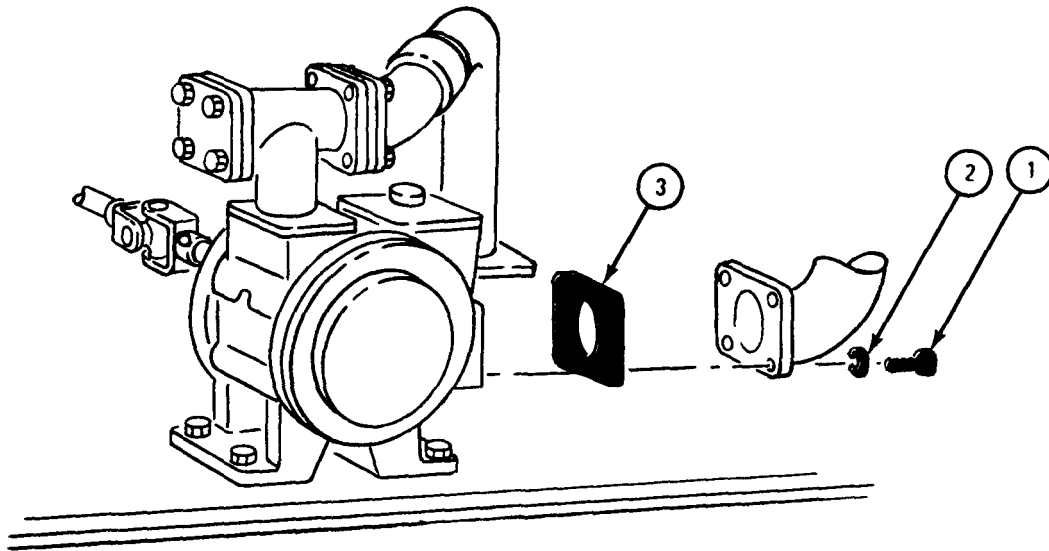

TA 046477

FRAME 3

1. Using 3/4-inch wrench, unscrew and take out four screws (1) with lock-washers (2).
2. Take off gasket (3) and throw it away.
3. Using screwdriver, loosen two clamps (4).

GO TO FRAME 4

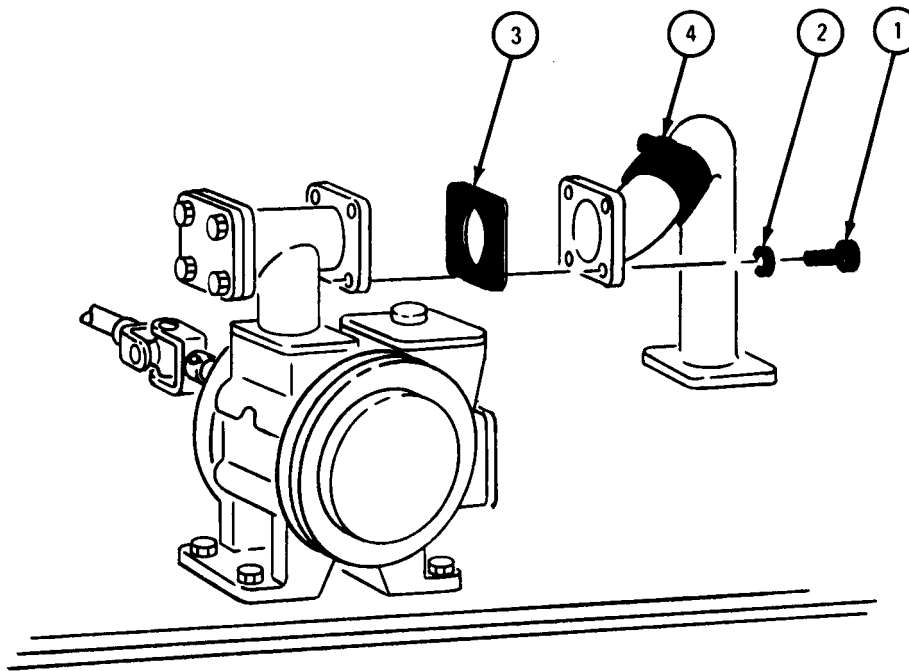

TA 046478

## FRAME 4

1. Using 9/16-inch wrenches, unscrew and take out four screws (1) and four nuts (2).
2. Slide pump (3) away from yoke (4) until pump is free. Take pump out.

GO TO FRAME 5

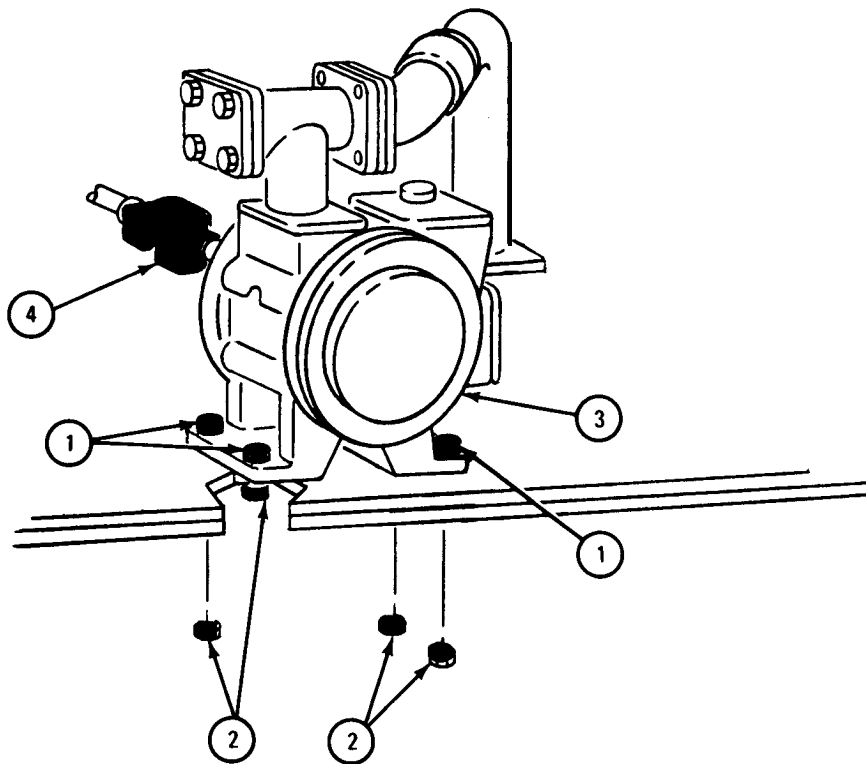

TA 046479

FRAME 5

1. Using screwdriver, pry key (1) out of shaft (2).
- END OF TASK

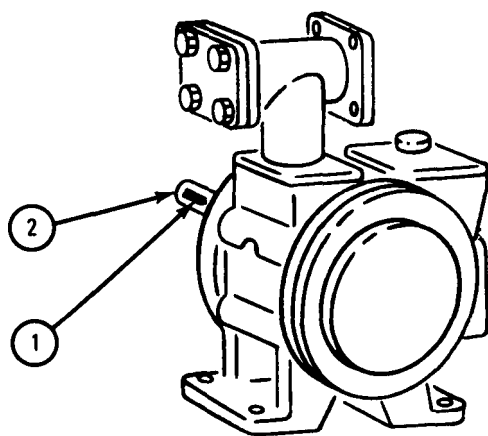

TA 046480

b. Replacement.

## FRAME 1

1. Put key (1) in hole in shaft (2). If needed, use mallet to drive key in.  
GO TO FRAME 2

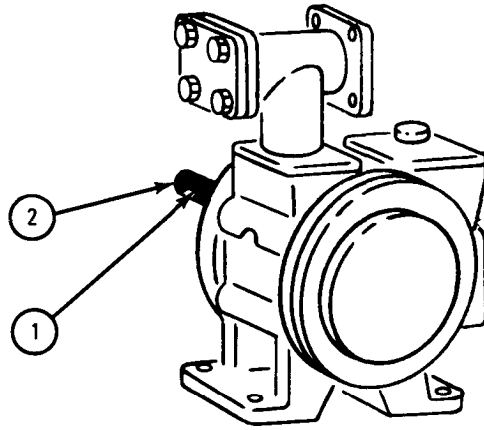

TA 046480

FRAME 2

1. Put pump (1) on shelf (2). Line up key (3) with keyway in yoke (4).
2. Slide pump (1) so shaft (5) goes into yoke (4).
3. Line up mounting holes in pump (1) and shelf (2).

GO TO FRAME 3

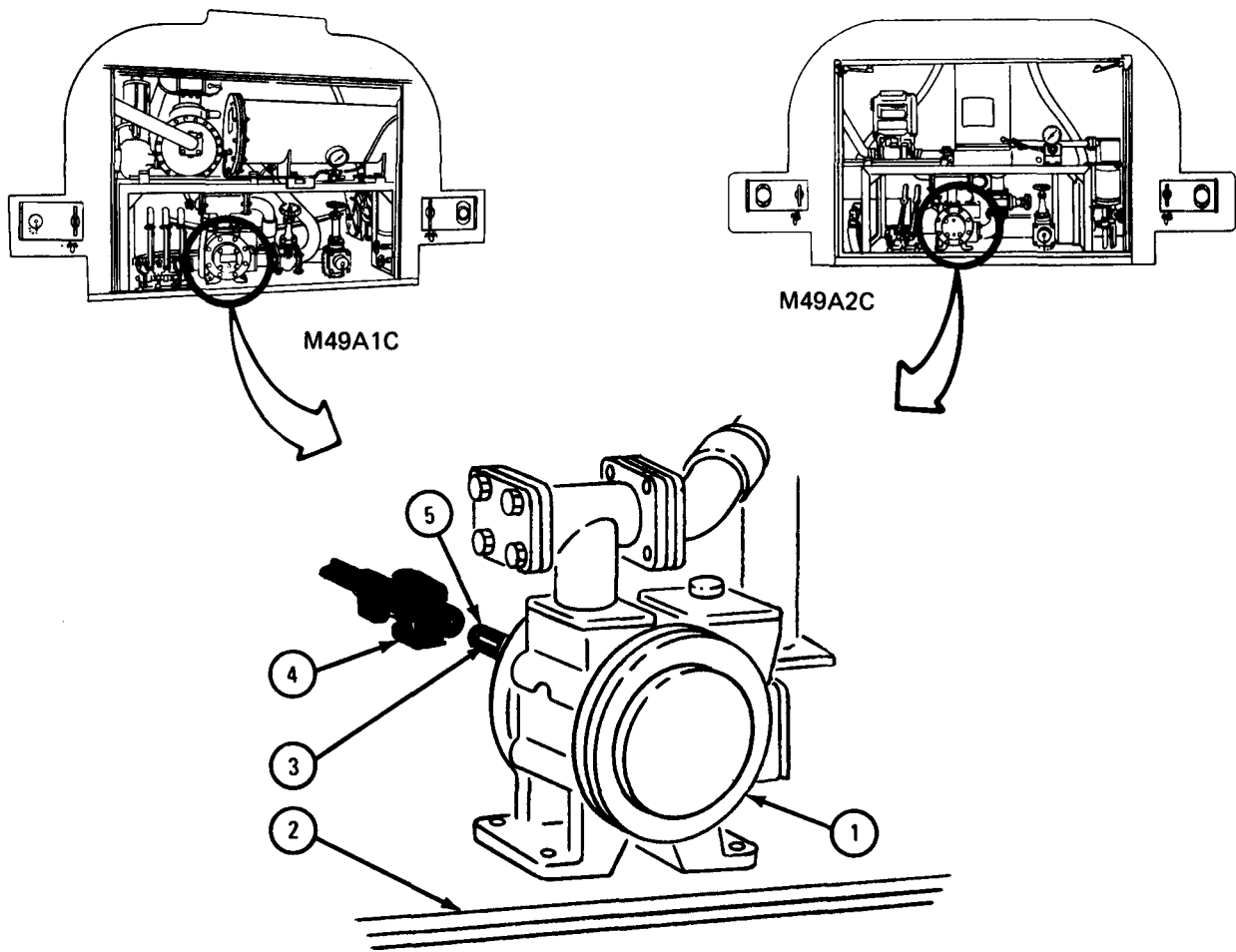

TA 046481



## FRAME 3

1. Put four screws (1) through mounting holes in pump (2) and shelf (3) and hold with 9/16-inch wrench. Using 9/16-inch wrench, screw on four nuts (4) until almost snug. Pump must be free to slide.

GO TO FRAME 4

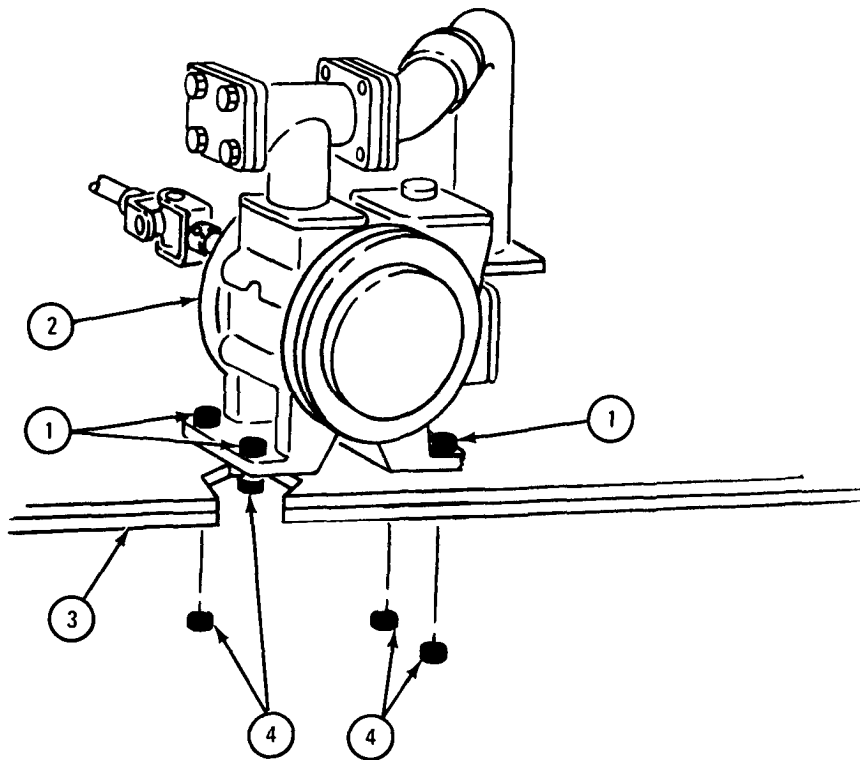

TA 046482

FRAME 4

1. Put inlet tube gasket (1) between pump flange (2) and pipe flange (3), lining up screw holes.
2. Put lockwashers (4) on four screws (5) and using 3/4-inch wrench, screw in and tighten screws.
3. Using screwdriver, tighten two clamps (6).

GO TO FRAME 5

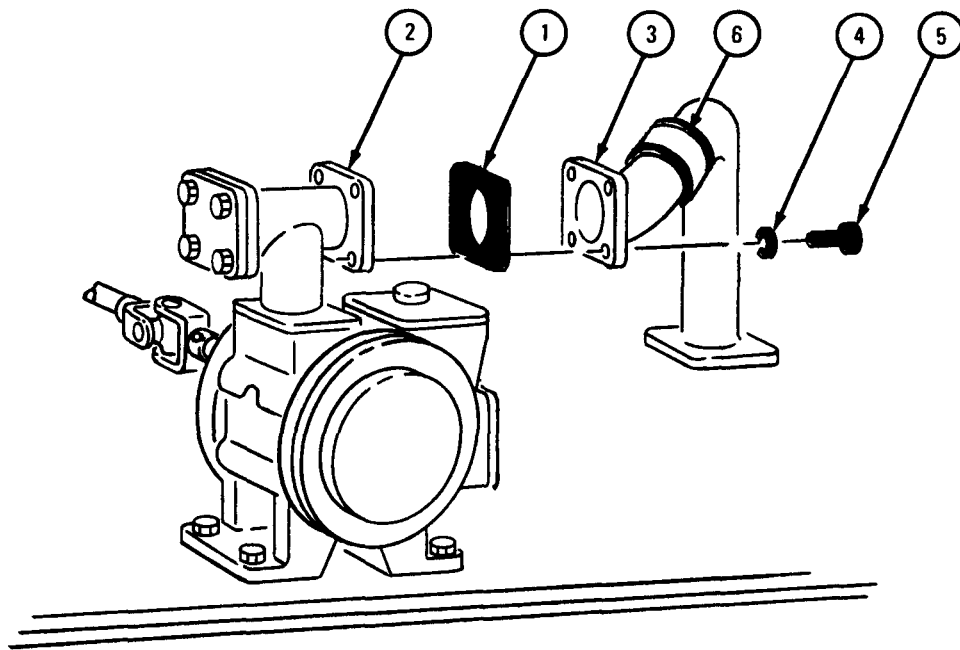

TA 046483

## FRAME 5

1. Put outlet tube gasket (1) between pump flange (2) and pipe flange (3), lining up screw holes.
2. Put lockwashers (4) on four screws (5) and using 9/16-inch wrench, screw in and tighten screws.

GO TO FRAME 6

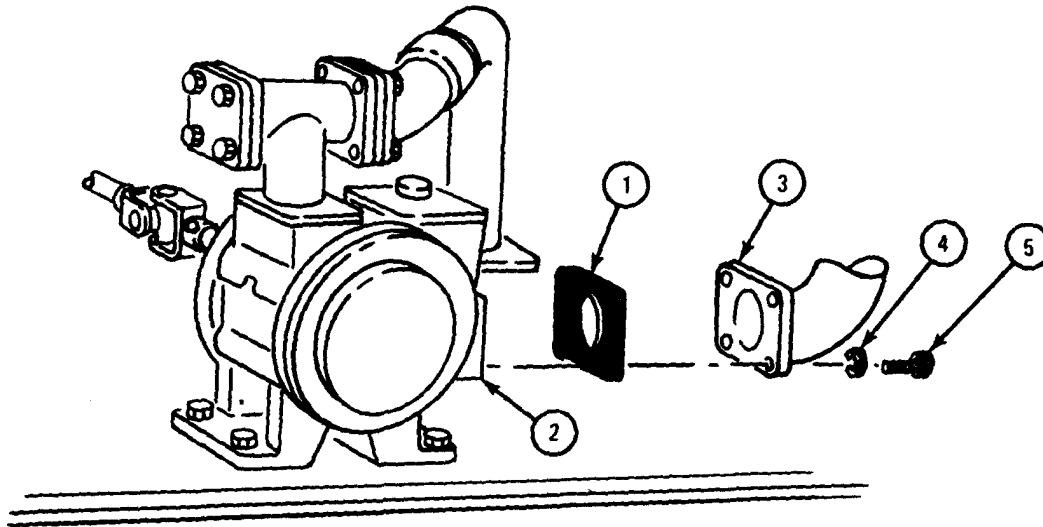

TA 046484

FRAME 6

1. Using 9/16-inch wrenches, hold four screws (1) and tighten four nuts (2).
2. Using allen wrench, tighten setscrew (3).
3. Close fuel truck rear compartment doors.

END OF TASK

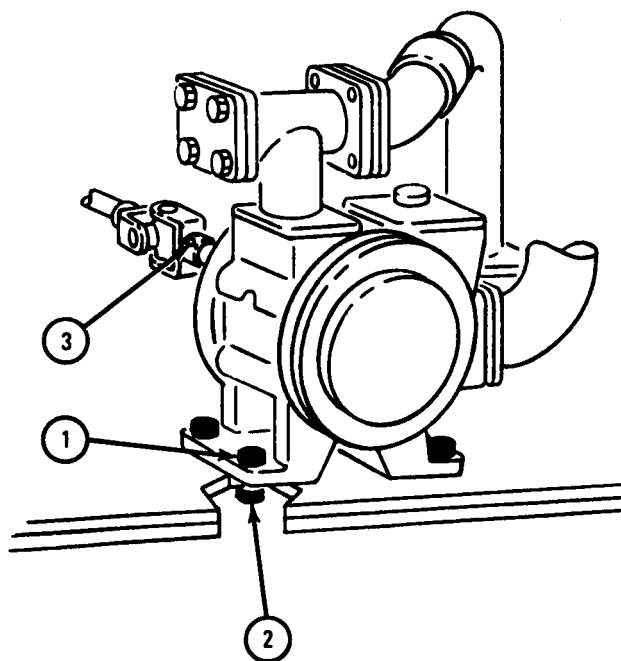

TA 046485

## 18-34. DELIVERY PUMP STRAINER AND GASKET REMOVAL AND REPLACEMENT.

TOOLS: 3/4-inch wrench  
Scraper

SUPPLIES: Delivery pump gasket  
Solvent, dry cleaning, type II (SD-2), Fed. Spec P-D-680  
Compressed air source, 30 psi max

PERSONNEL: One

EQUIPMENT CONDITION: Truck parked, engine off, handbrake set.

WARNING

Smoking, flame, sparks, and glowing or hot objects are not allowed within 50 feet of work area. Fuel may burn, causing explosion, injury to personnel, and damage to equipment.

a. Removal.

## FRAME 1

1. Using wrench, unscrew and take out four screws (1). Take off four lock-washers (2).
2. Take off strainer cover (3) and gasket (4). Throw away gasket.

WARNING

Dry cleaning solvent is flammable. Do not use near an open flame. Keep a fire extinguisher nearby when solvent is used. Use only in well-ventilated places. Failure to do this may result in injury to personnel and damage to equipment.

3. Using solvent, clean strainer cover (3). Use scraper, if needed, to get off all gasket pieces.

GO TO FRAME 2

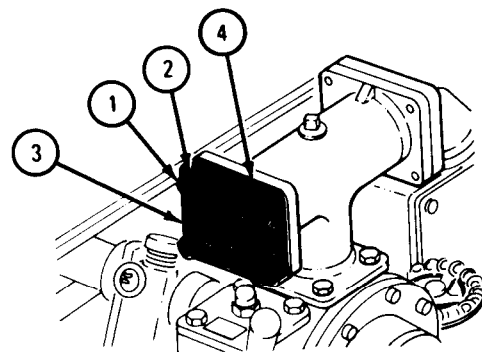
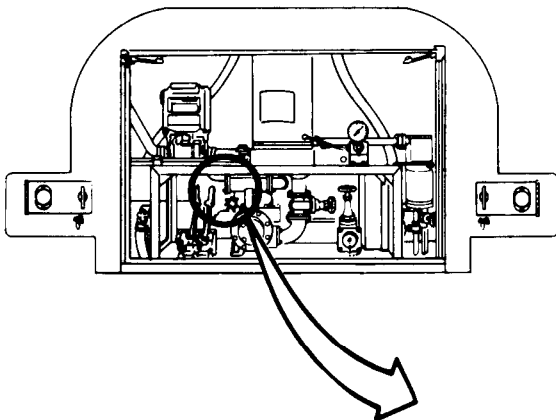

TA 046411

FRAME 2

1. Take out strainer (1) from strainer housing (2).

WARNING

Dry cleaning solvent is flammable. Do not use near an open flame. Keep a fire extinguisher nearby when solvent is used. Use only in well-ventilated places. Failure to do this may result in injury to personnel and damage to equipment.

2. Using solvent, clean strainer (1). Dry with compressed air. Make sure there is no dirt left in strainer.
3. Using solvent, clean flange (3). Use scraper, if needed, to get off all gasket pieces. Do not get any gasket pieces in strainer housing (2).

END OF TASK

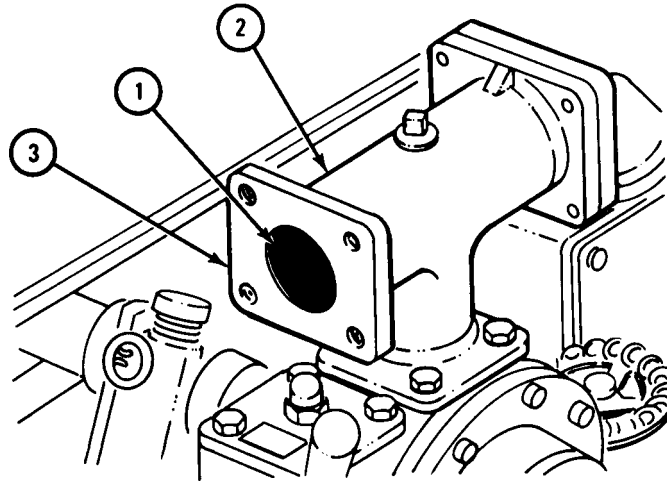

TA 046412

b. Replacement.

## FRAME 1

1. Put strainer (1) into strainer housing (2).
2. Put lockwashers (3) on four screws (4).
3. Put gasket (5) on flange (6), alining holes. Hold gasket in place and put strainer cover (7) against gasket, dining holes.
4. Using wrench, screw in and tighten four screws (4) with lockwashers (3).

END OF TASK

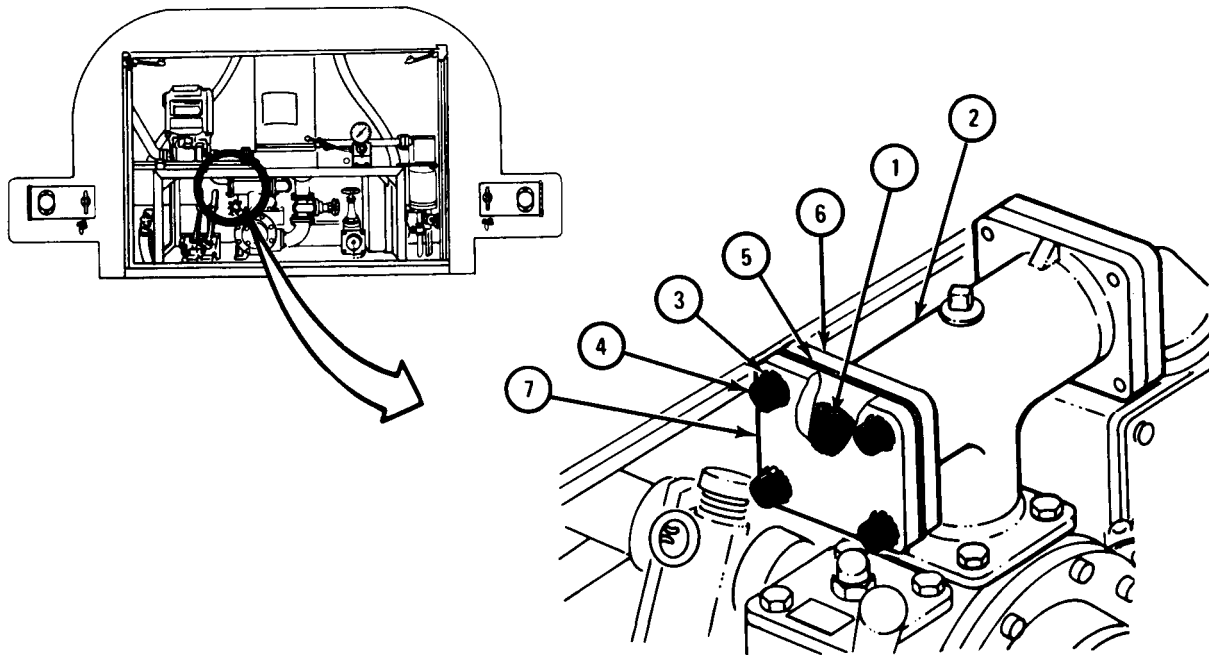

TA 046413

18-35. DELIVERY PUMP PROPELLER SHAFTS REMOVAL AND REPLACEMENT  
(TRUCKS M49A1C AND M49A2C).

TOOLS: 9/16-inch wrench (2) 6-inch ruler  
 1/8-inch sockethead screw key 3/4-inch wrench (2)  
 (Allen wrench or equivalent) Brass or plastic head hammer  
 3/16-inch sockethead screw key Slip joint pliers  
 (Allen wrench or equivalent) Brass drift punch

SUPPLIES: None

PERSONNEL: One

EQUIPMENT CONDITION: Truck parked, engine off, handbrake set, wheels chocked.

a. Removal.

FRAME 1

1. Working under truck where front drive shaft (1) connects to intermediate shaft (2) and using 3/16-inch allen wrench, loosen setscrew (3).
2. Slide collar (4) to front of truck until it stops.

GO TO FRAME 2

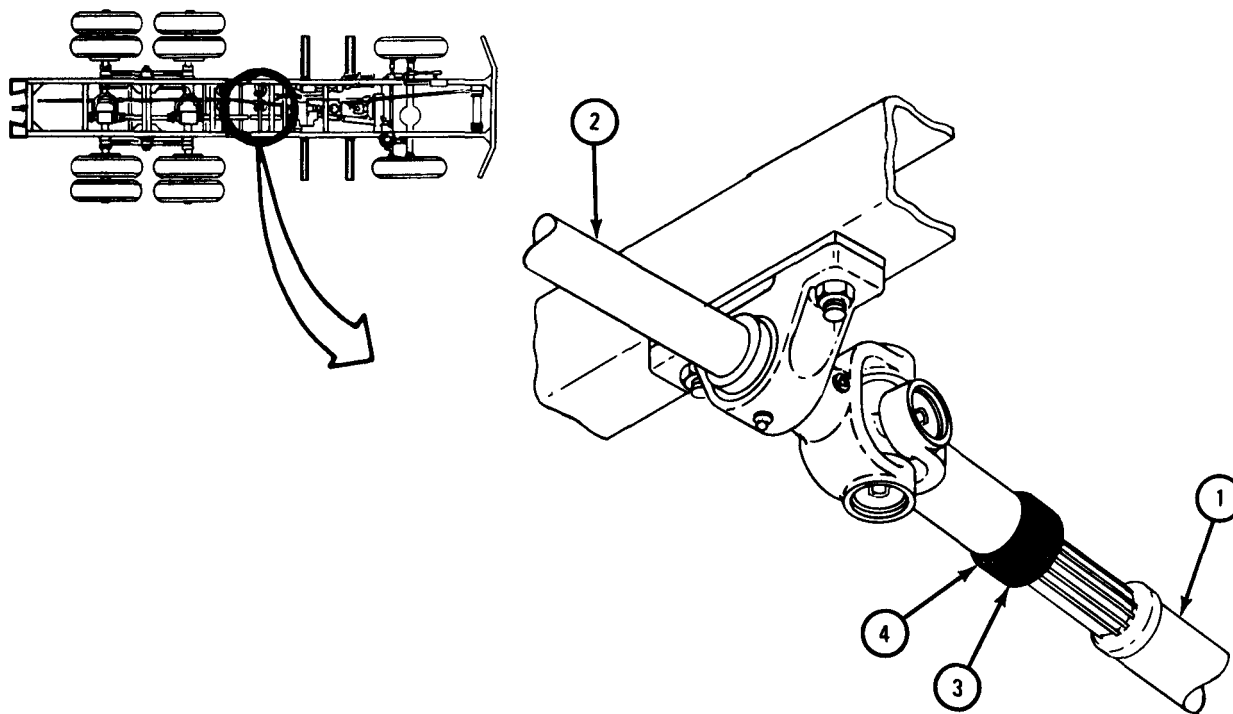

TA 046533



## FRAME 2

1. Working where front drive shaft (1) connects to power takeoff flange (2) and using 9/16-inch wrench, unscrew and take off four screws (3) and nuts (4).
2. Take front drive shaft (1) off power takeoff flange (2). Pull front drive shaft out of universal joint (5).
3. Using 3/16-inch allen wrench, loosen setscrew (6). Take off collar (7).

GO TO FRAME 3

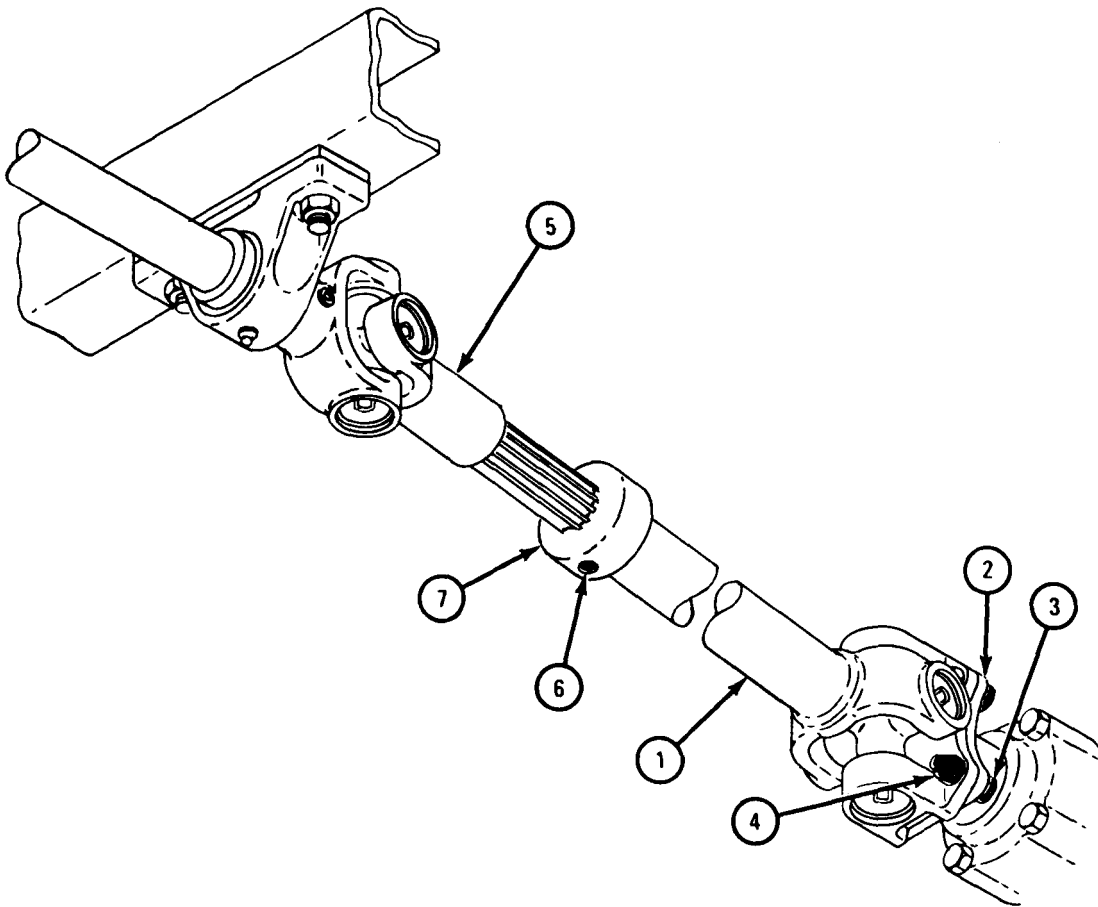

TA 046534

FRAME 3

1. Using 3/16-inch allen wrench, loosen setscrew (1).
  2. Using hammer, tap universal joint (2) until it comes off shaft (3).
- GO TO FRAME 4

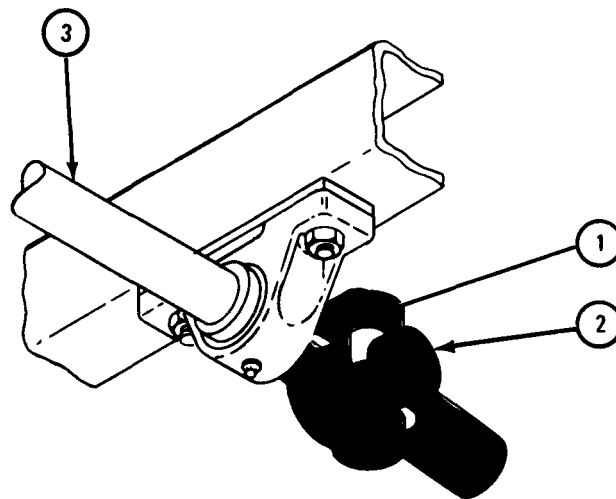

TA 046535

## FRAME 4

1. Go to rear of truck and open rear compartment doors.
2. Using 3/16-inch allen wrench, loosen setscrew (1).
3. Slide collar (2) away from universal joint yoke (3) as far as it will go.

GO TO FRAME 5

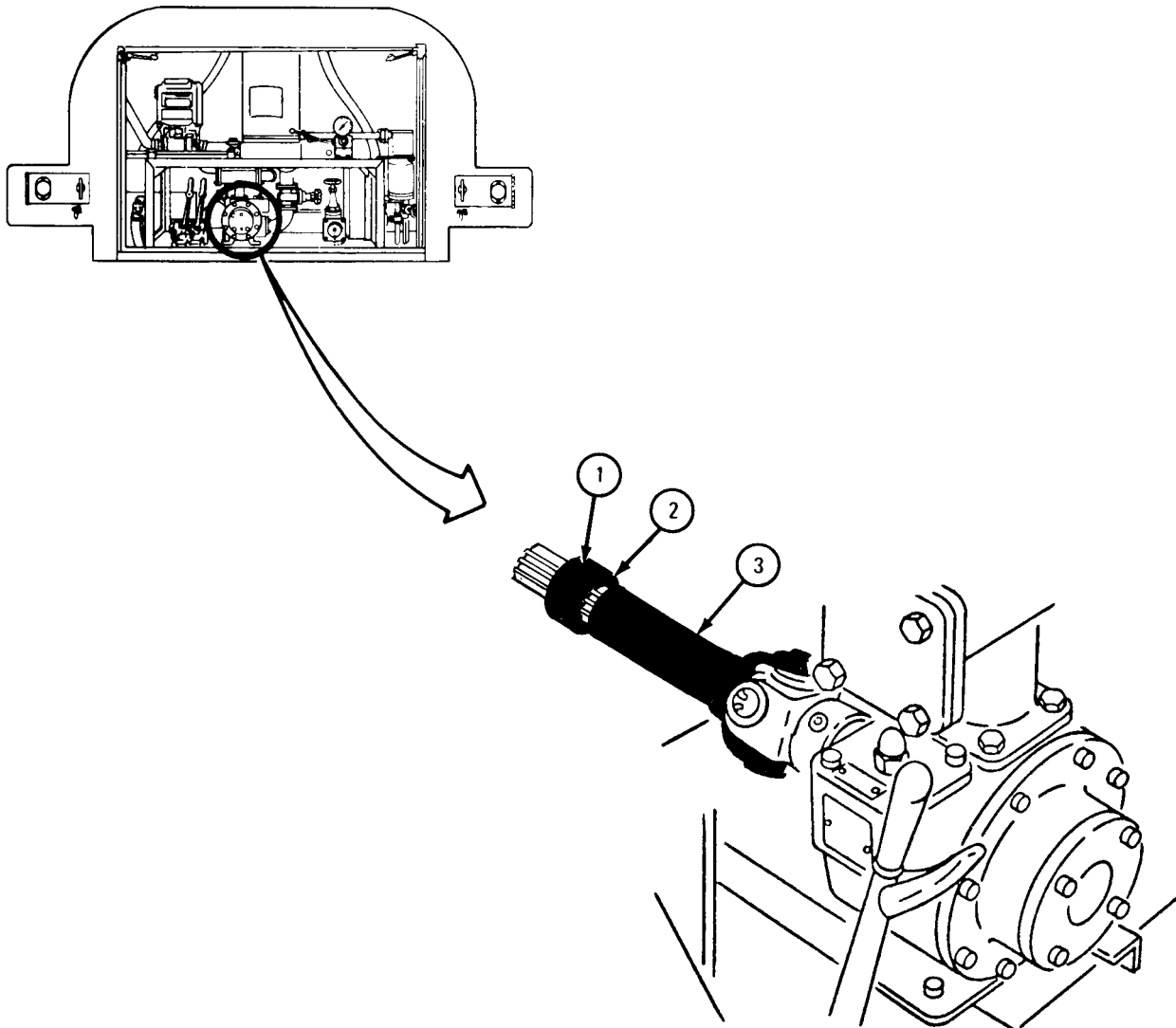

TA 046158

FRAME 5

1. Working under truck at rear end of intermediate shaft (1) and using 3/16-inch allen wrench, loosen setscrew (2).
2. Using hammer, tap universal joint (3) until it comes off intermediate shaft (1).
3. Pull rear shaft (4) from pump universal joint yoke (5) and take out rear shaft.
4. Slide collar (6) off rear shaft (4).

GO TO FRAME 6

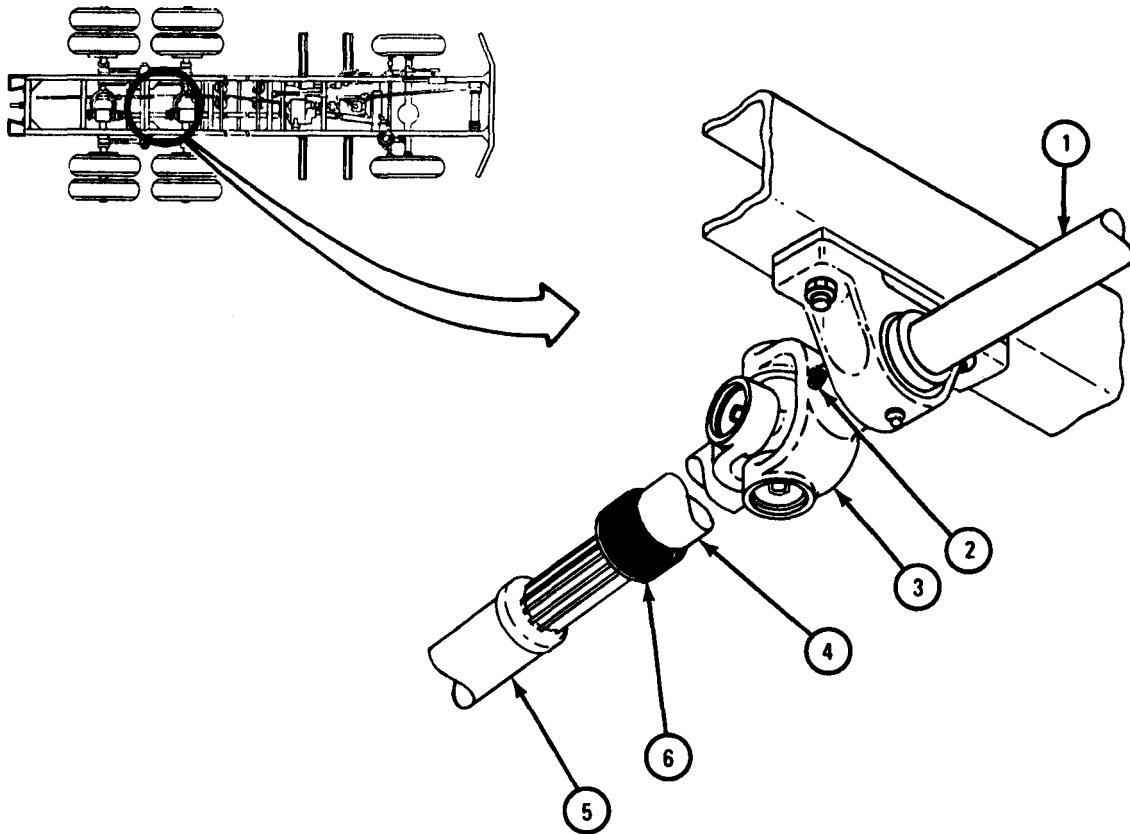

TA 046537

## FRAME 6

1. Using 3/4-inch wrenches, unscrew and take off two nuts (1) and screws (2).
2. Take off spacer (3) and lower end of intermediate shaft (4) to frame crossmember.
3. Go to other end of intermediate shaft (4) and do steps 1 and 2 again.
4. Take out intermediate shaft (4).

GO TO FRAME 7

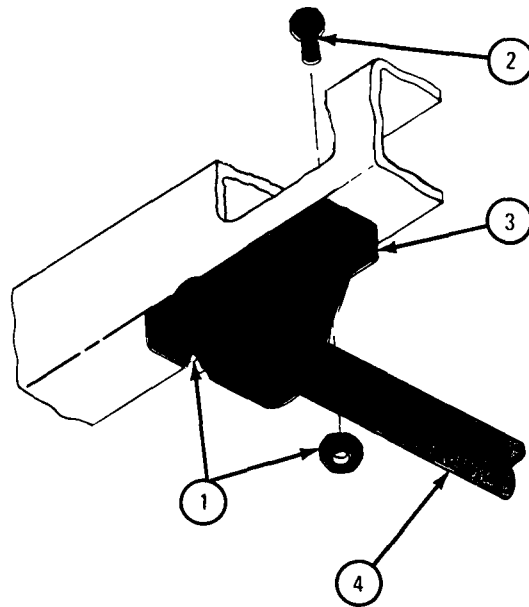

TA 046538

FRAME 7

1. Using slip joint pliers, pull key (1) out of intermediate shaft (2).
2. Using 1/8-inch allen wrench, loosen two setscrews (3).
3. Using hammer and punch, tap out bearing (4) and take pillow block (5) off end of intermediate shaft (2).
4. Do steps 1 through 3 again on other end of intermediate shaft (2).

GO TO FRAME 8

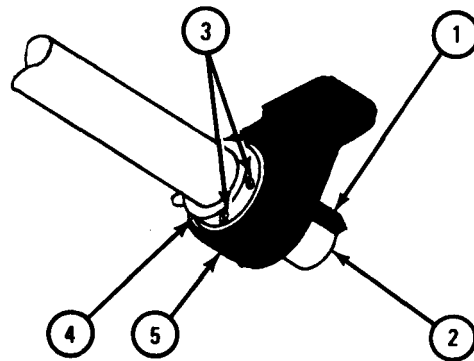

TA 046162

## FRAME 8

1. Go to rear compartment.
2. Using 3/16-inch allen wrench, loosen setscrew (1).
3. Push universal joint (2) off pump shaft (3). Take off universal joint.
4. Take key (4) out of pump shaft (3).

END OF TASK

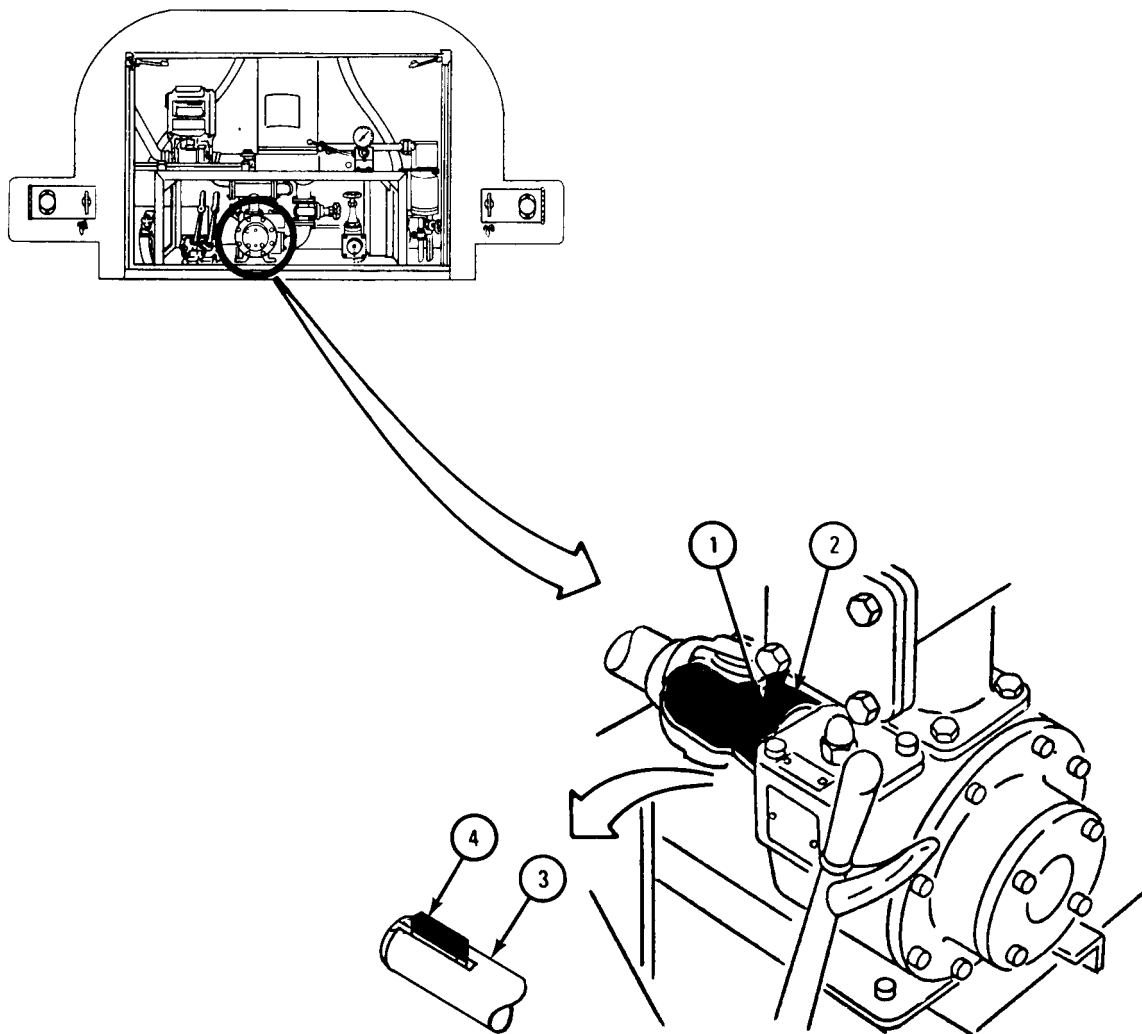

TA 046539

b. Repair.

(1) Repair is limited to the removal and replacement of parts found damaged during inspection.

(2) Refer to para 18-36 for removal and installation of bearing and journal universal.

c. Replacement.

FRAME 1

1. Using hammer, tap key (1) into pump shaft (2).
2. Put universal joint (3) onto pump shaft (2), lining up keyway. Make sure universal joint is on pump shaft all the way.
3. Using 3/16-inch allen wrench, tighten setscrew (4).
4. Point yoke (5) to front of truck with wide groove on bottom.

GO TO FRAME 2

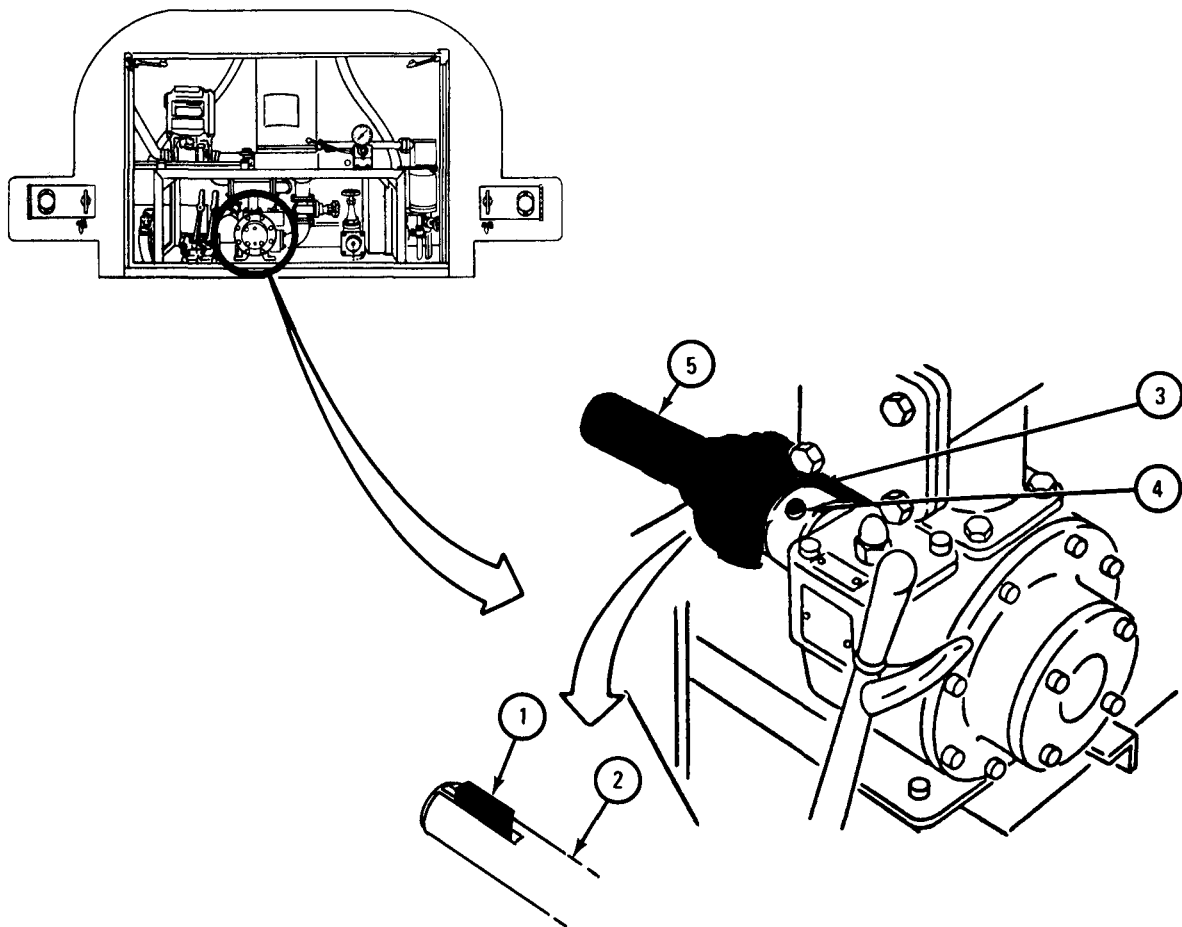

TA 046540



## FRAME 2

1. Slide pillow block (1) onto intermediate shaft (2).
2. Using hammer and punch, tap bearing (3) into pillow block (1) if it does not slide in easily.
3. Using hammer and punch, tap key (4) into keyway in intermediate shaft (2).
4. Do steps 1 through 3 again on other end of intermediate shaft (2).

GO TO FRAME 3

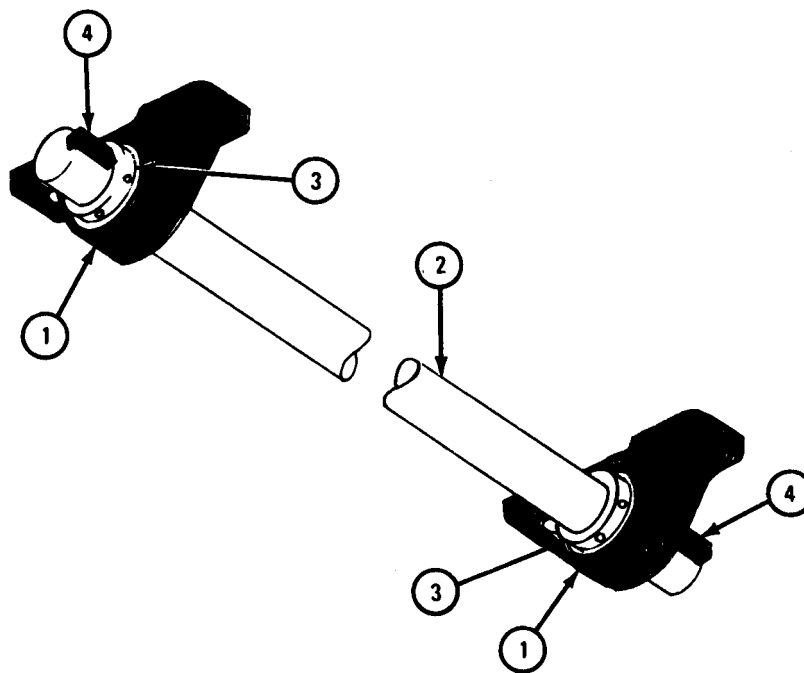

TA 046486

FRAME 3

1. Working under truck, lay back end of intermediate shaft (1) on frame crossmember (2).
2. Put spacer (3) on front pillow block (4). Put pillow block in place on frame crossmember (5), alining screw holes.
3. Put two screws (6) through holes in frame crossmember (5).
4. Using 3/4-inch wrenches, screw on and tighten two nuts (7).
5. Do steps 2 through 4 again for other end of intermediate shaft (1).
6. Move intermediate shaft (1) so same amount of shaft goes through each pillow block (4).
7. Using 1/8-inch allen wrench, tighten two setscrews (8).

GO TO FRAME 4

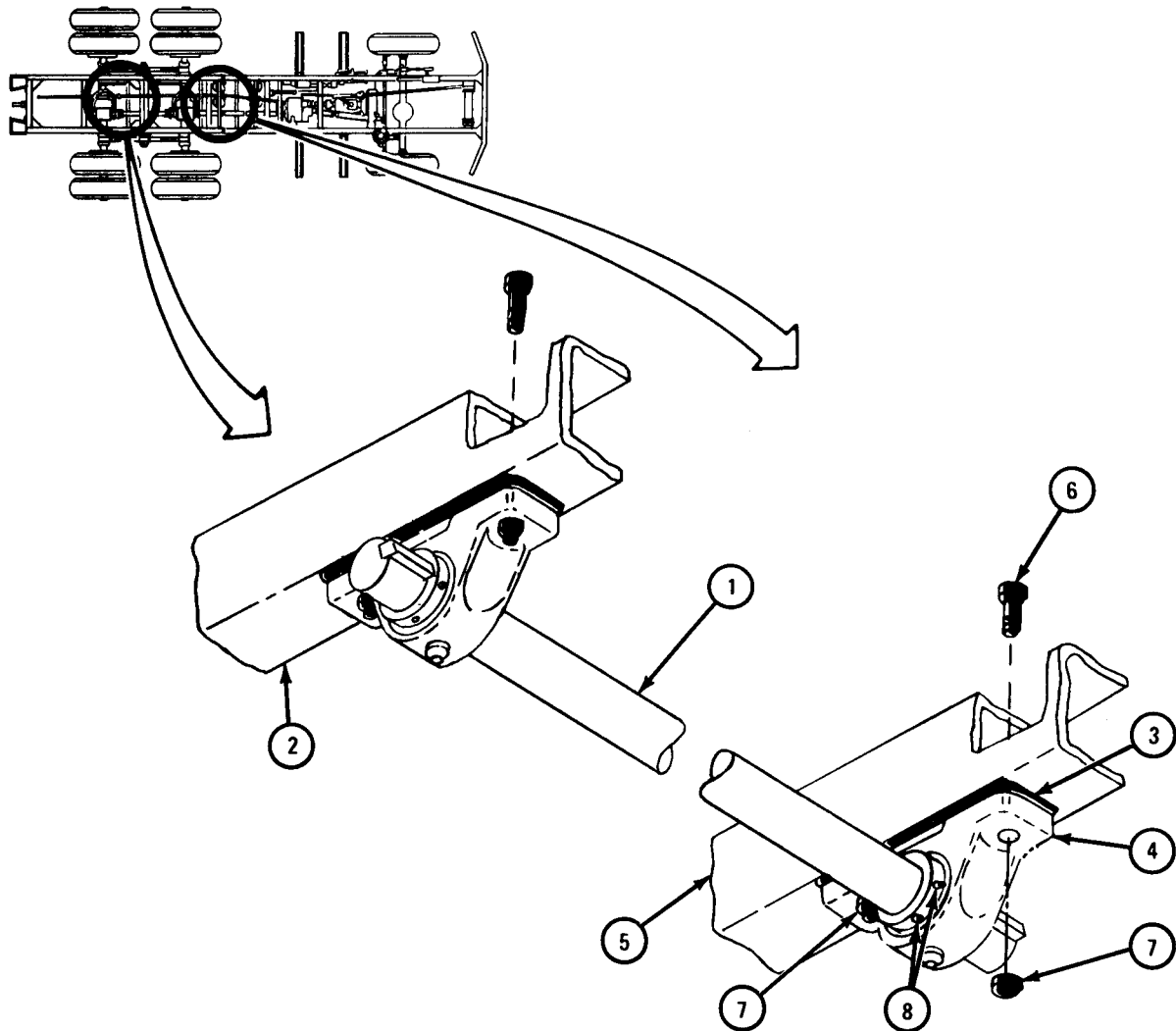

TA 046541

## FRAME 4

1. Put collar (1) onto rear shaft (2) with setscrew (3) lined up with wide groove (4) in rear shaft. Using 3/16-inch allen wrench, tighten setscrew, then unscrew it one turn.
2. Look into yoke from pump (5). Find place where wide groove (4) fits. Line up wide grooves and put rear shaft (2) into yoke from pump.
3. Line up keyway in universal joint (6) with key (7) on intermediate shaft (8) and slide universal joint all the way onto intermediate shaft.
4. Using 3/16-inch allen wrench, tighten setscrew (9).

GO TO FRAME 5

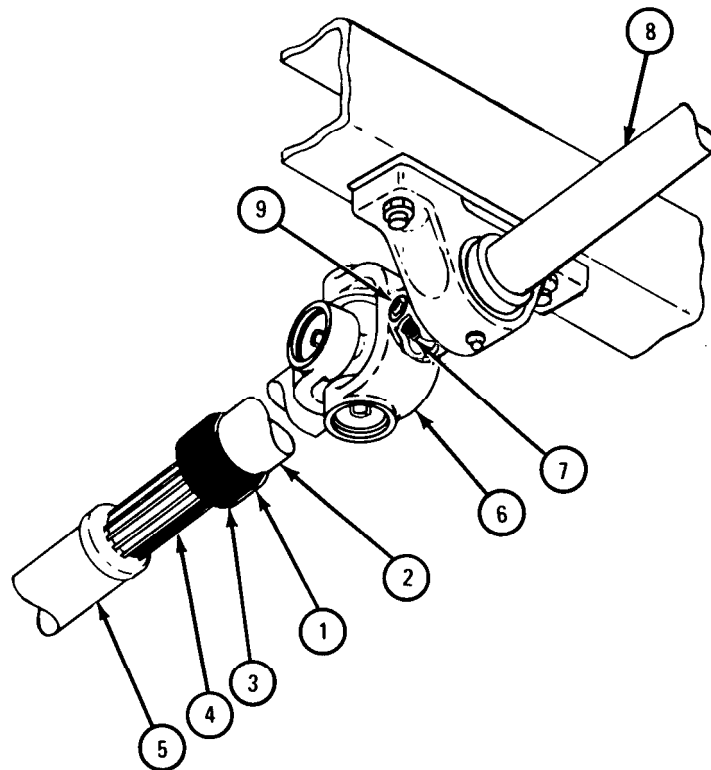

TA 046138

FRAME 5

1. Put key (1) in keyway in intermediate shaft (2).
2. Lineup keyway in universal joint (3) with key in intermediate shaft (2). Put universal joint all the way onto intermediate shaft.
3. Using 3/16-inch all wrench, tighten setscrew (4).

GO TO FRAME 6

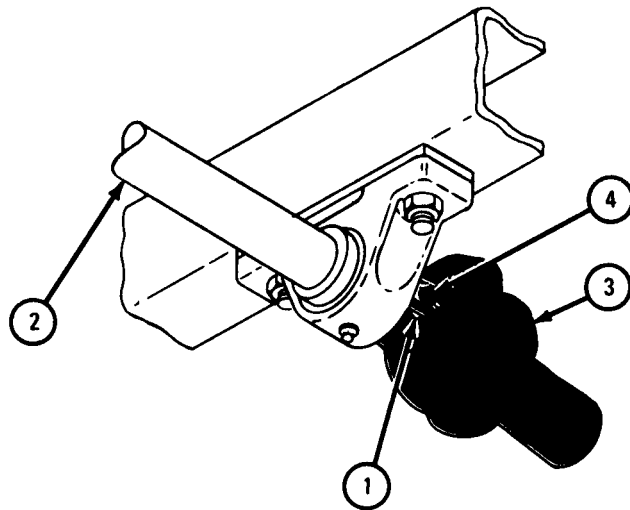

TA 046546

## FRAME 6

1. Pull collar (1) onto front driveshaft (2) with setscrew (3) lined up with wide groove (4). Using 3/16-inch allen wrench, tighten setscrew, then unscrew it one turn.
2. Look into universal joint (5). Find place where wide groove fits. Line up wide groove in front driveshaft (2) and put front driveshaft into universal joint.
3. Put front drive shaft (2) **onto power** takeoff flange (6), lining up screw holes. Put four screws (7) through screw holes and using 9/16-inch wrenches, screw on and tighten four nuts (8) .
4. Slide collar (1) so that it is about 1/8 inch away from universal joint (5). Using 3/16-inch allen wrench, tighten setscrew (3).

GO TO FRAME 7

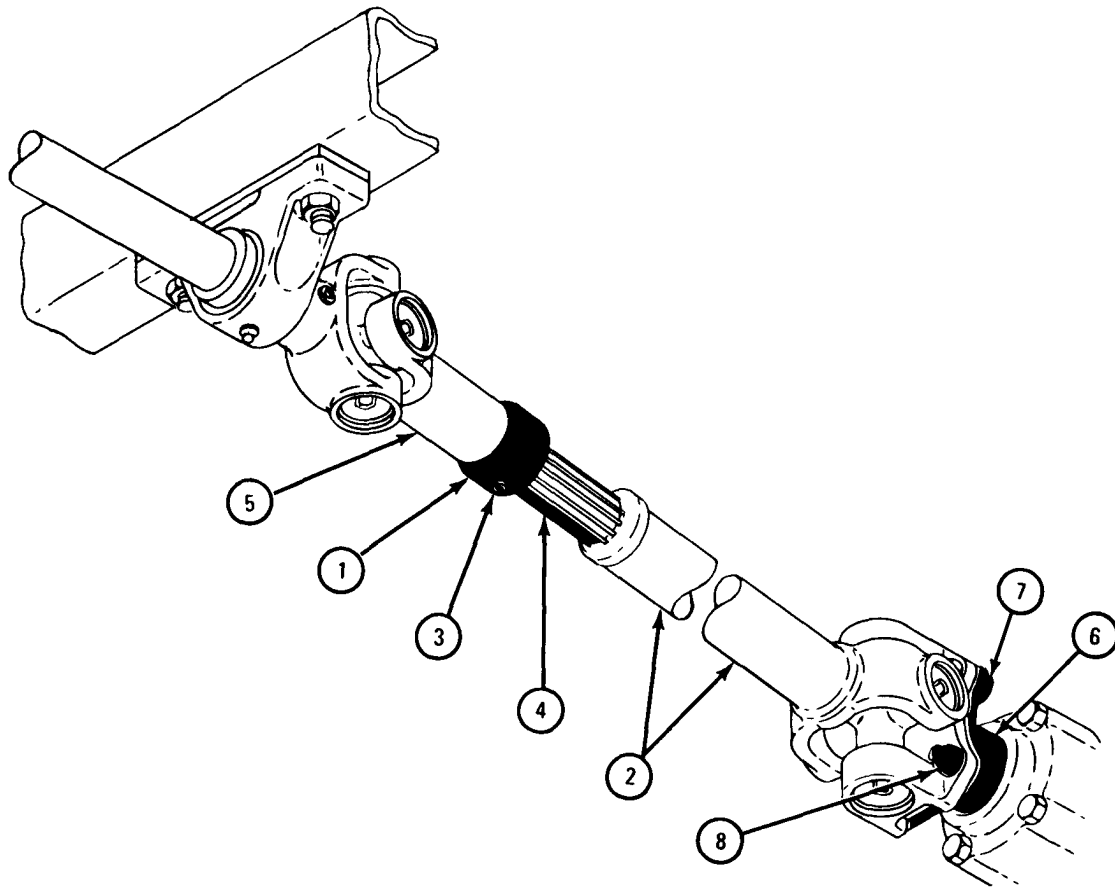

TA 046547

FRAME 7

1. Slide collar (1) so it is about 1/8inch away from universal joint shaft (2).  
Using 3/16-inch allen wrench, tighten setscrew (3).
2. Close rear compartment doors.

END OF TASK

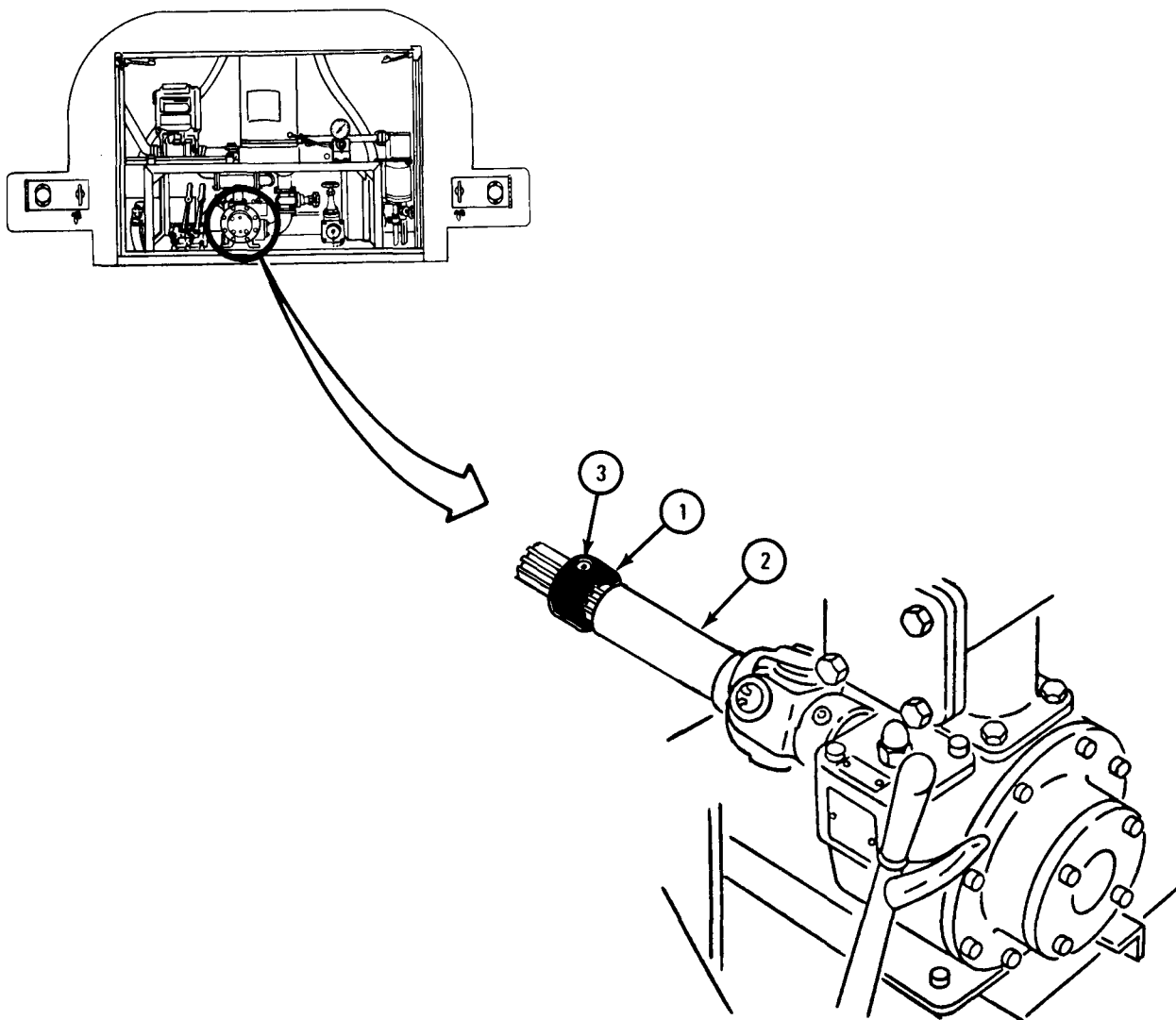

TA 046549

### 18-36. PUMP DRIVE SHAFT BEARING AND JOURNAL UNIVERSAL REMOVAL AND REPLACEMENT.

#### NOTE

All four pump drive shaft universals do not look the same. Some yokes may not look like the pictures. This task is still the same for all pump drive shaft universals.

TOOLS: 5/16-inch deep well socket wrench  
Retaining ring pliers  
Drive pin punch  
Hammer  
Brass punch

SUPPLIES: Artillery and automotive grease, type GAA, MIL-G-10924

PERSONNEL: Two

EQUIPMENT CONDITION, Truck parked, engine off, handbrake set.

a. Preliminary Procedure. Remove drive shaft with universal to be worked on. Refer to para 18-59.

b. Removal.

#### FRAME 1

1. Using wrench, unscrew and take off grease fitting (1).
2. Using retaining ring pliers, take out four retaining rings (2).

GO TO FRAME 2

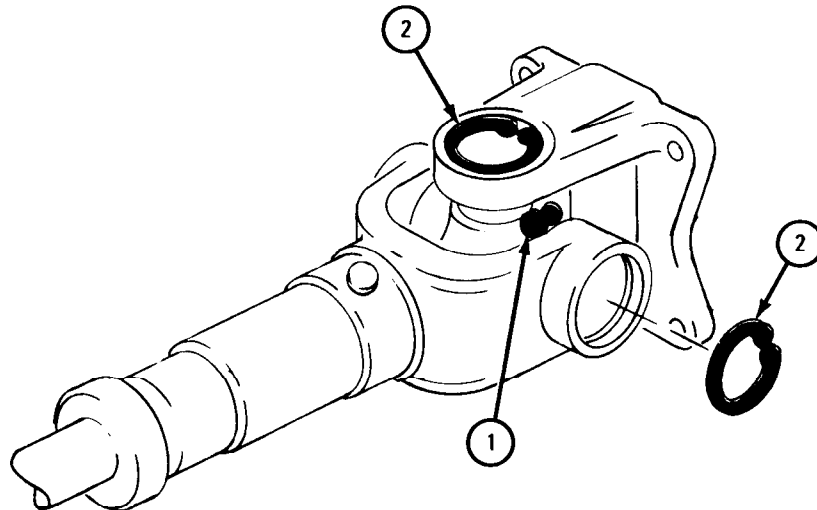

TA 046414

FRAME 2

Soldier A 1. Hold yoke (1) on wood block as shown.

NOTE

Drive pin punch must be a little smaller than end of journal (2) so punch can go through bore of bearing.

Soldier B 2. Using hammer and drive pin punch, hammer end of journal (2) down into yoke (1). Bearing (3) will come out at bottom of yoke.

Soldier A 3. Turn yoke (1) over.

Soldier B 4. Do step 2 again for other bearing (3). When bearing falls out, take spider (4) out of yoke (1) by letting one end down into hole where bearing was. Take out other end first.

GO TO FRAME 3

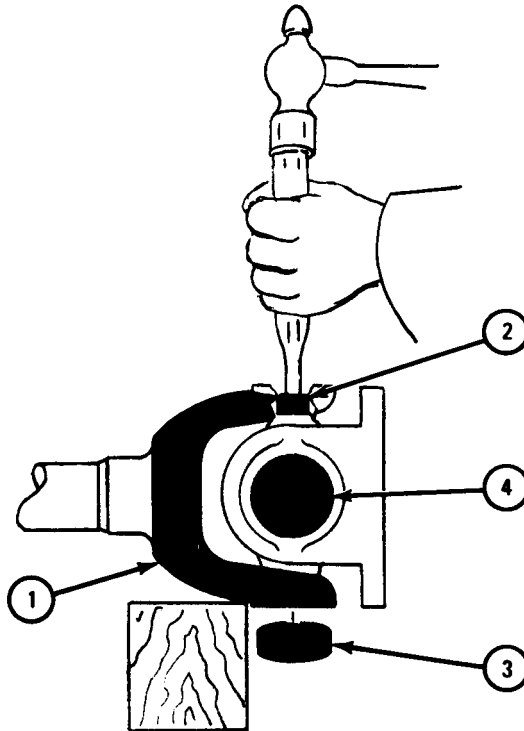

TA 046415



## FRAME 3

Soldier A 1. Hold yoke (1) on wood block.

## NOTE

Drive pin punch must be a little smaller than end of journal (2) so punch can go through bore of bearing.

Soldier B 2. Using hammer and drive pin punch, hammer end of journal (2) down into yoke (1). Bearing (3) will come out at bottom of yoke.

Soldier A 3. Turn yoke (1) over.

Soldier B 4. Do step 2 again for other bearing (3). When bearing falls out, take spider (4) out of yoke (1) by letting one end down into hole where bearing was. Take out other end first.

END OF TASK

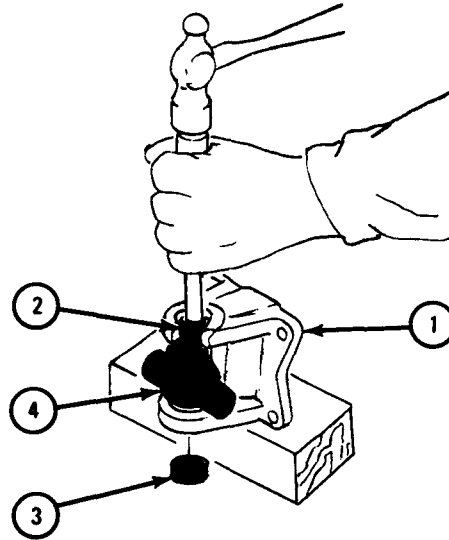

TA 046416

c. Replacement.

FRAME 1

- Soldier A 1. Take grease and work it in on rollers inside bearing (1). Do this to four bearings that will be used.
- Soldier B 2. Hold yoke (2) with one hole up and the other down.
- Soldier A 3. Put spider (3) in yoke (2) by first putting one end down into hole where bearing (4) goes. The other end can now be put in.
- Soldier B 4. Hold spider (3) up into top hole as far as it will go.
- Soldier A 5. Put bearing (1) on end of spider (3). Press bearing into yoke (2).
6. Put brass punch on bearing (1). Using hammer, drive bearing into yoke (2).
7. Using retaining ring pliers, put retaining ring (5) into yoke (2).
- Soldier B 8. Hold spider (3) in bearing (1) and turn yoke (2) over. Lift spider (3) about halfway out of bearing.
- Soldier A 9. Do steps 5, 6, and 7 again for bearing (4).
- GO TO FRAME 2

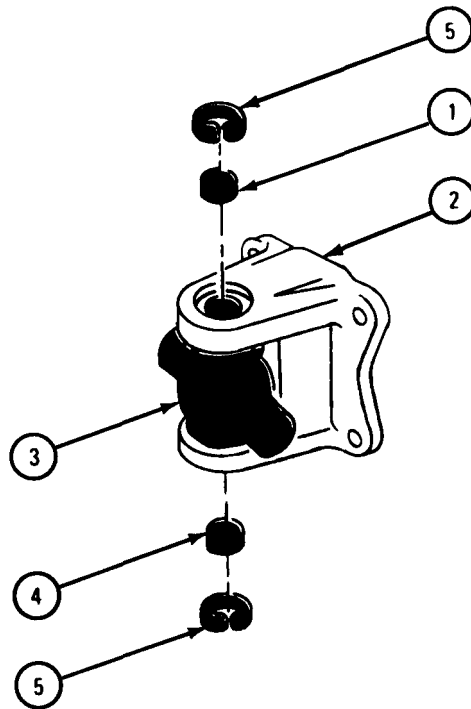

TA 046417

## FRAME 2

- Soldier A 1. Hold yoke (1) with one hole up and the other down.
- Soldier B 2. Put spider (2) in yoke (1) by first putting one end down into hole where bearing (3) goes. The other end can now be put in.
- Soldier A 3. Hold spider (2) up into top hole as far as it will go.
- Soldier B 4. Put bearing (4) on end of spider (2). Press bearing into yoke (1).
5. Put brass punch on bearing (4). Using hammer, drive bearing into yoke (1).
6. Using retaining ring pliers, put retaining ring (5) into yoke (1).
- Soldier A 7. Hold spider (2) in bearing (4) and turn yoke (1) over. Lift spider about halfway out of bearing.
- Soldier B 8. Do steps 4, 5, and 6 again for bearing (3).

## NOTE

Follow-on Maintenance Action Required:

Replace drive shaft in truck. Refer to para 18-59.

END OF TASK

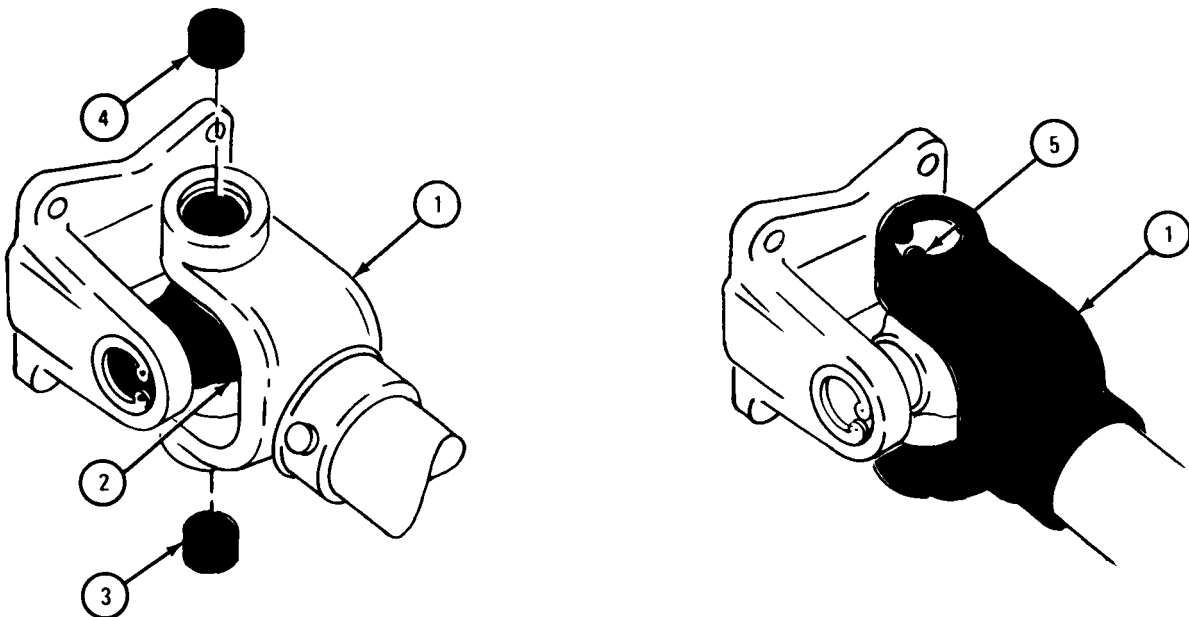

TA 046418

18-37. FUEL DRAIN MANIFOLD REMOVAL AND REPLACEMENT (TRUCK M49A2C).

TOOLS: 3/4-inch open end wrench (2) Hammer  
7/8-inch open end wrench Wood chisel  
9/16-inch open end wrench (2) Flat-tip screwdriver  
Stiff brush  
Scraper

SUPPLIES: Gate valve gasket (2)  
Manifold gasket (2)  
Solvent, dry cleaning, type II (SD-2), Fed. Spec P-D-680

PERSONNEL: Two

EQUIPMENT CONDITION: Truck parked, engine off, handbrake set.

WARNING

Smoking, sparks or open flame are not allowed within 50 feet of fuel truck during this task. Fuel may burn, causing explosion, injury to personnel, and damage to equipment.

- a. Preliminary Procedure. Drain fuel from truck. Refer to TM 9-2320-209-10.
- b. Removal.

FRAME 1

- 1. Open truck rear compartment doors.
- 2. Using 3/4-inch wrenches, unscrew and take out four nuts (1) and bolts (2). Take off gravity delivery line gate valve (3). Take off gasket (4) and throw it away.

GO TO FRAME 2

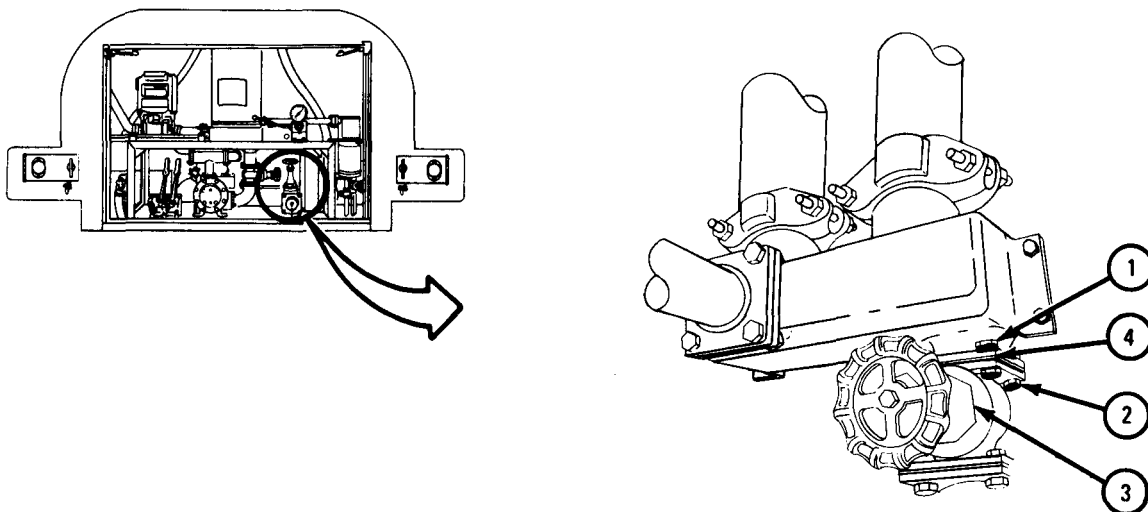

TA 046615

## FRAME 2

1. Using 3/4-inch wrenches, unscrew and take off four nuts (1) and four screws (2).
2. Using screwdriver, unscrew screw (3) until clamp (4) is loose. Take elbow (5) out of hose (6). Leave clamp on hose.
3. Take off and throw away gasket (7).

GO TO FRAME 3

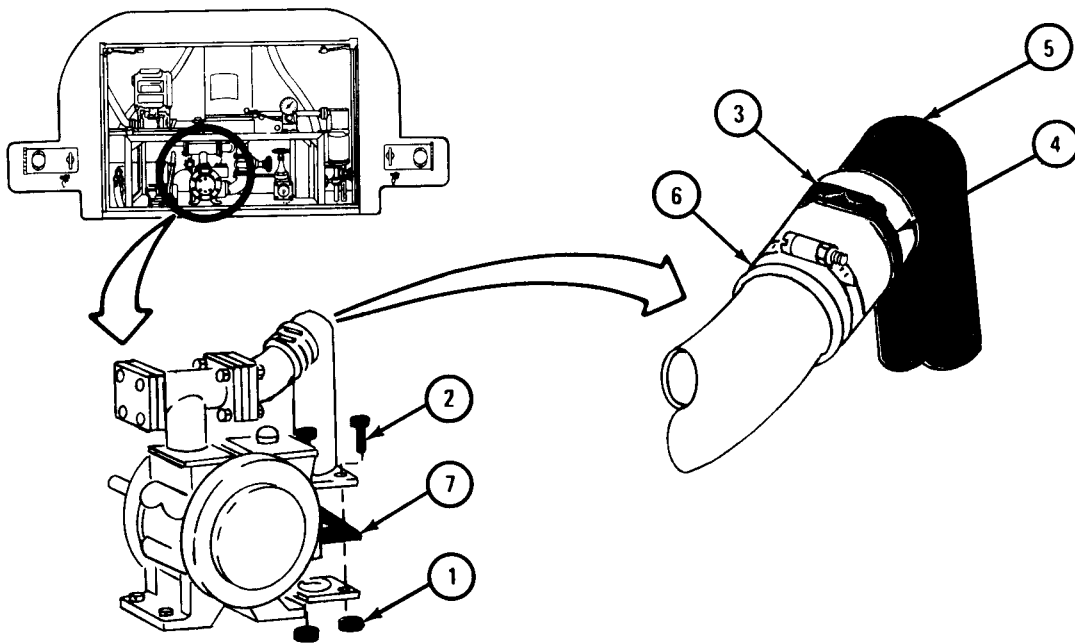

TA 083355

FRAME 3

1. Using 7/8-inch wrench, unscrew and take off four nuts (1).
2. Take off two top clamp halves (2).

GO TO FRAME 4

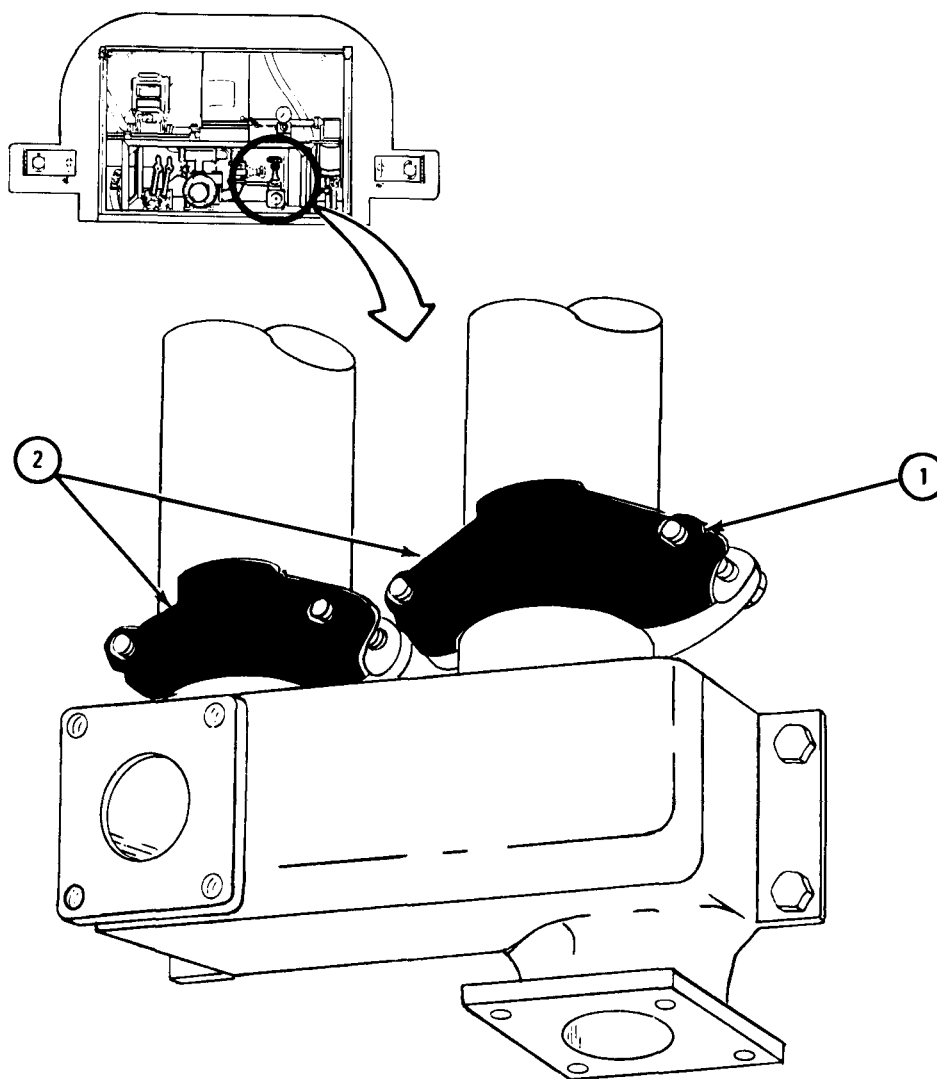

TA 046616

## FRAME 4

## NOTE

The right front nut may be covered by wooden sill of truck. If nut is covered, using wood chisel and hammer, cut away sill where nut is.

- Soldier A 1. Working in rear compartment, using 9/16-inch wrench, hold four bolts (1).
- Soldier B 2. Working under truck, using 9/16-inch wrench, unscrew and take off four nuts (2).
- Soldier A 3. Take out four bolts (1) and manifold (3). Take off two bottom clamp halves (4) with bolts (5). Take off and throw away two gaskets (6).

END OF TASK

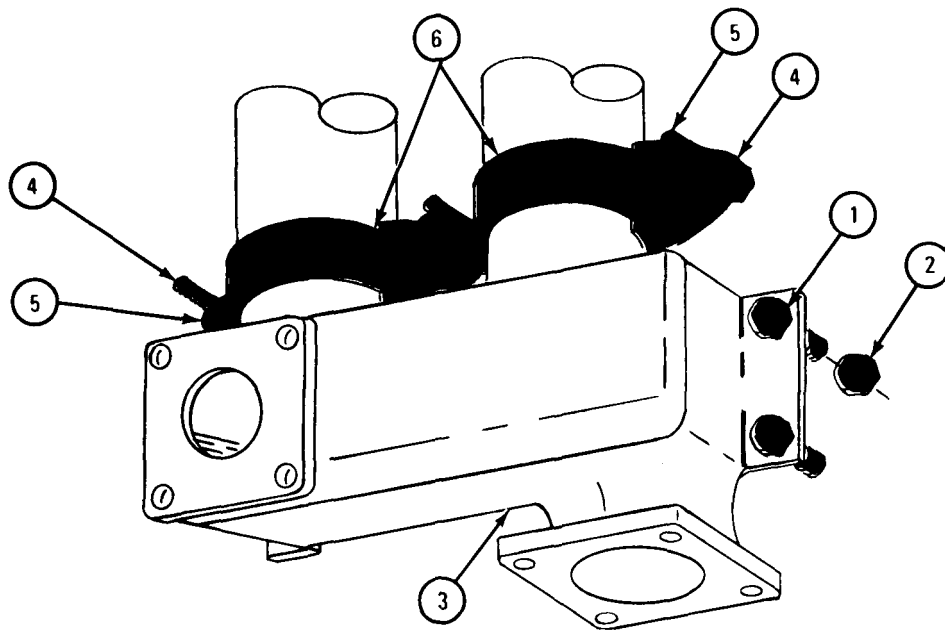

TA 046617

c. Cleaning and Inspection.

WARNING

Dry cleaning solvent is flammable. Do not use near an open flame. Keep a fire extinguisher nearby when solvent is used. Use only in well-ventilated places. Failure to do this may result in injury to personnel and damage to equipment.

- (1) Using scraper, clean off any old gasket material on manifold.
- (2) Using stiff brush and solvent, clean inside of manifold.
- (3) Check inside of manifold. If there is rust or corrosion, throw manifold away. Get new manifold in its place.



d. Replacement.

## FRAME 1

- Soldier A 1. Working in rear compartment, put on two gaskets (1) about three inches from end of tubes (2). Put on two bottom clamp halves (3) with bolts (4).
2. Put manifold (5) in place, alining holes for four bolts (6). Put bolts in place and using 9/16-inch wrench, hold them.
- Soldier B 3. Working under truck, using 9/16-inch wrench, screw on and tighten four nuts (7).
- Soldier A 4. Slide two gaskets (1) down so they join tubes (2 and 8).
- GO TO FRAME 2

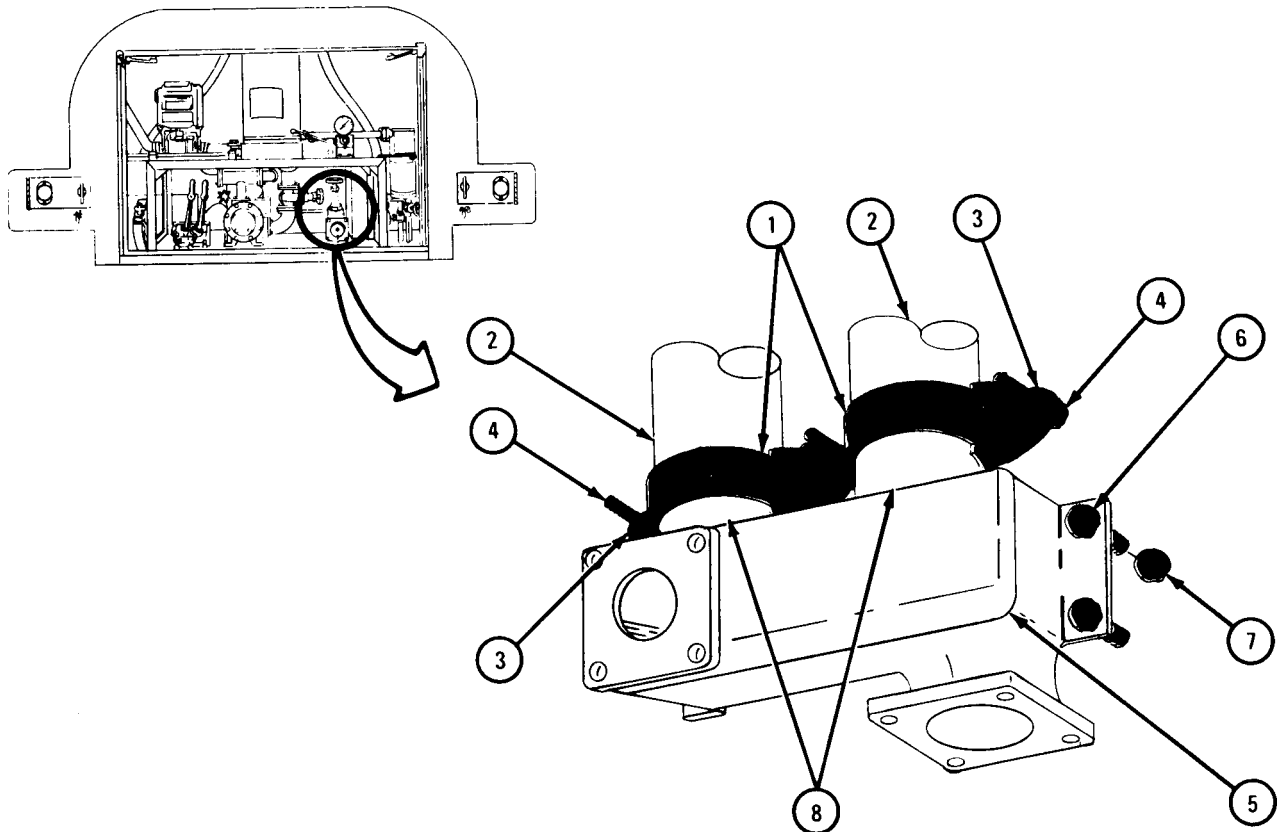

TA 046618

FRAME 2

1. Put two top clamp halves (1) in place. Check that top and bottom clamp halves hold two gaskets (2).

2. Using 7/8-inch wrench, screw on and tighten four nuts (3).

GO TO FRAME 3

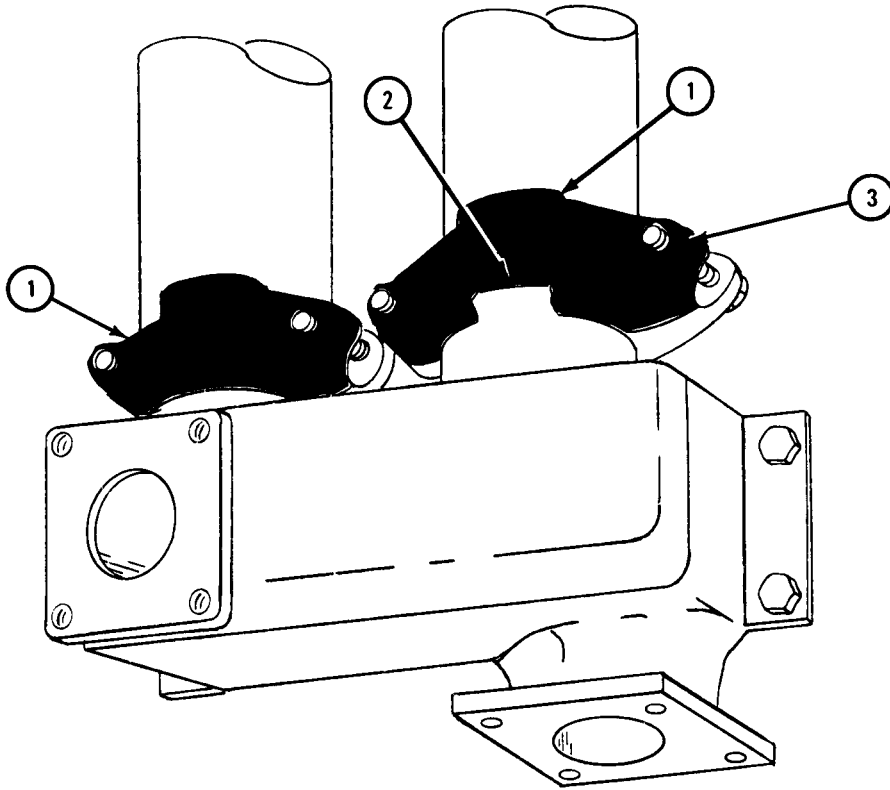

TA 046619

## FRAME 3

1. Put elbow (1) into hose (2).
2. Put gasket (3) in place. Put elbow (1) in place, alining holes for four bolts (4).
3. Using 3/4-inch wrenches, screw on and tighten four nuts (5).
4. Put clamp (6) in place so it holds hose (2) to elbow (1). Using screwdriver, tighten screw (7).

GO TO FRAME 4

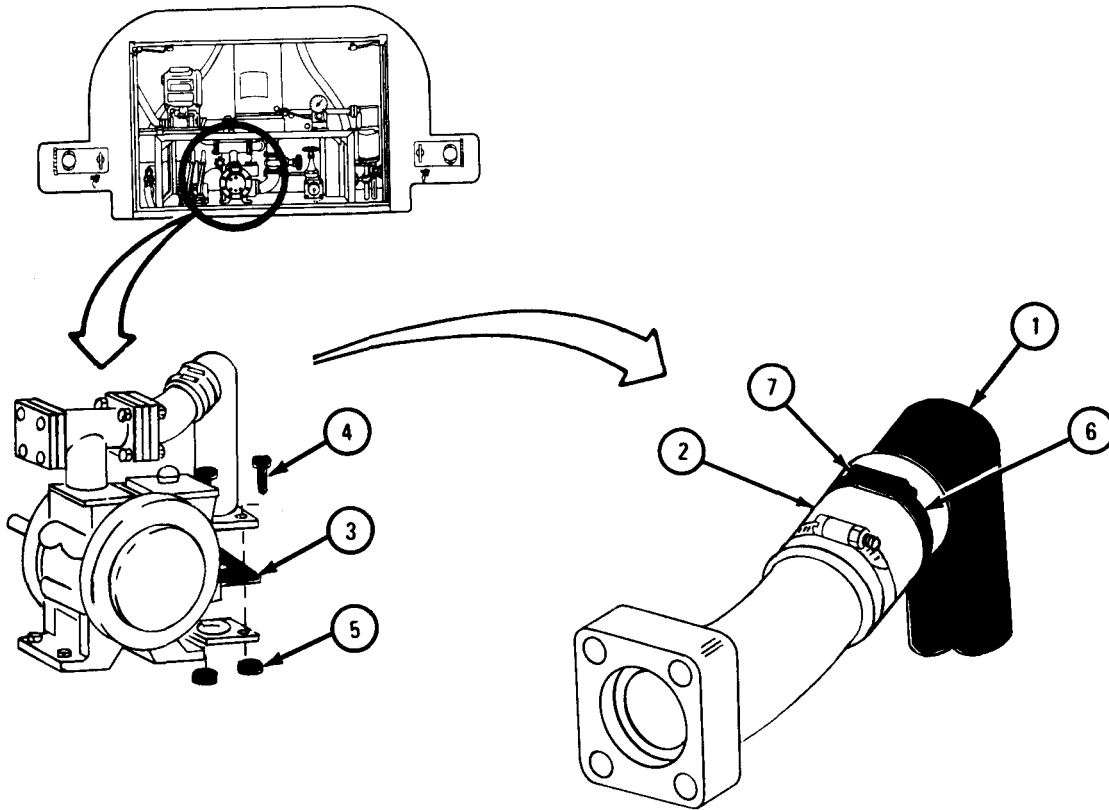

TA 083356

FRAME 4

1. Put gasket (1) on gravity delivery line gate valve (2) and put them to manifold (3), alining holes.
2. Using 3/4-inch wrenches, screw in and tighten four nuts (4) and bolts (5).
3. Turn handle (6) on gravity delivery line gate valve (2) to the right until it stops.
4. Close truck rear compartment doors.

END OF TASK

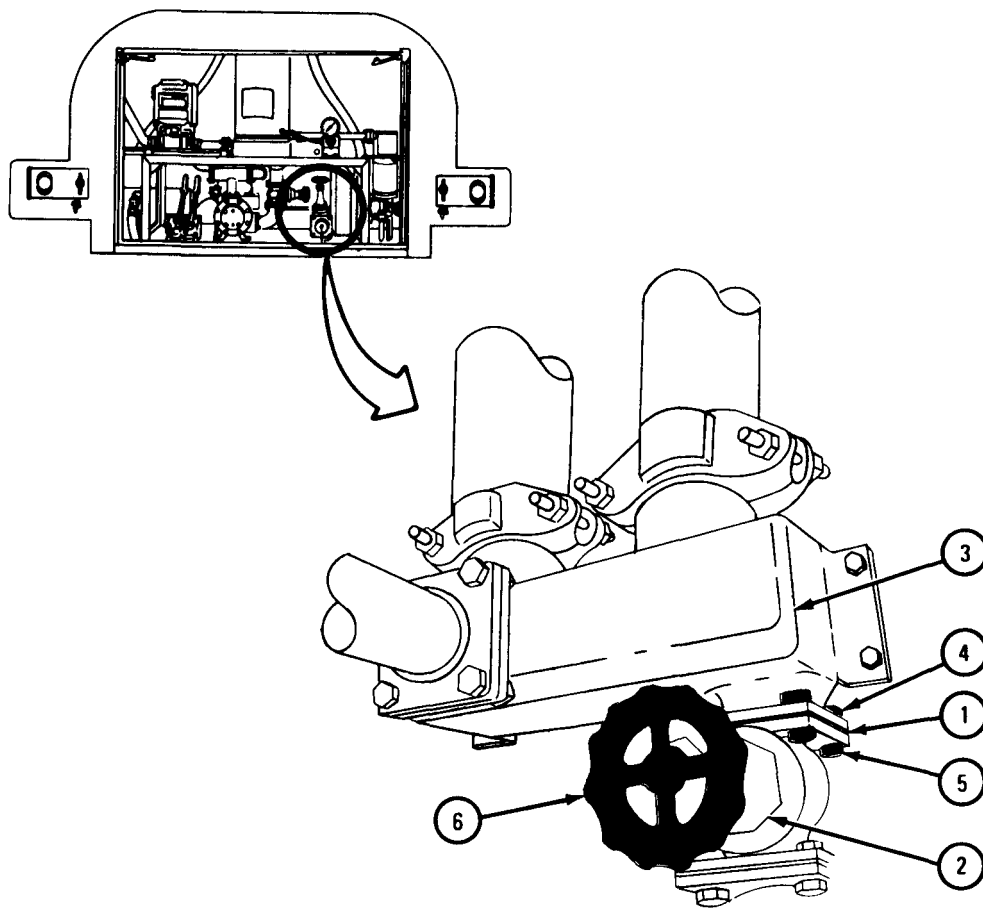

TA 046620

18-38. PUMP-TO-MANIFOLD HOSE REMOVAL AND REPLACEMENT (TRUCKS M49A1C and M49A2C).

TOOLS: 3/4-inch wrench (2)  
 3/8-inch drive ratchet set  
 Flat-tip screwdriver

SUPPLIES: Pump-to-manifold hose  
 Pump-to-manifold hose upper gasket  
 Pump-to-manifold hose lower gasket  
 Diesel fuel

PERSONNEL: One

EQUIPMENT CONDITION: Truck parked, engine off, handbrake set.

WARNING

Smoking, sparks or open flame are not allowed within 50 feet of fuel truck during this task. Fuel may burn, causing explosion, injury to personnel, and damage to equipment.

a. Removal.

FRAME 1

1. Open fuel truck rear compartment doors.
2. Using 3/4-inch wrenches, unscrew and take off four nuts (1) and four screws (2).
3. Lift up lower pipe (3) and take off and throw away gasket (4).

GO TO FRAME 2

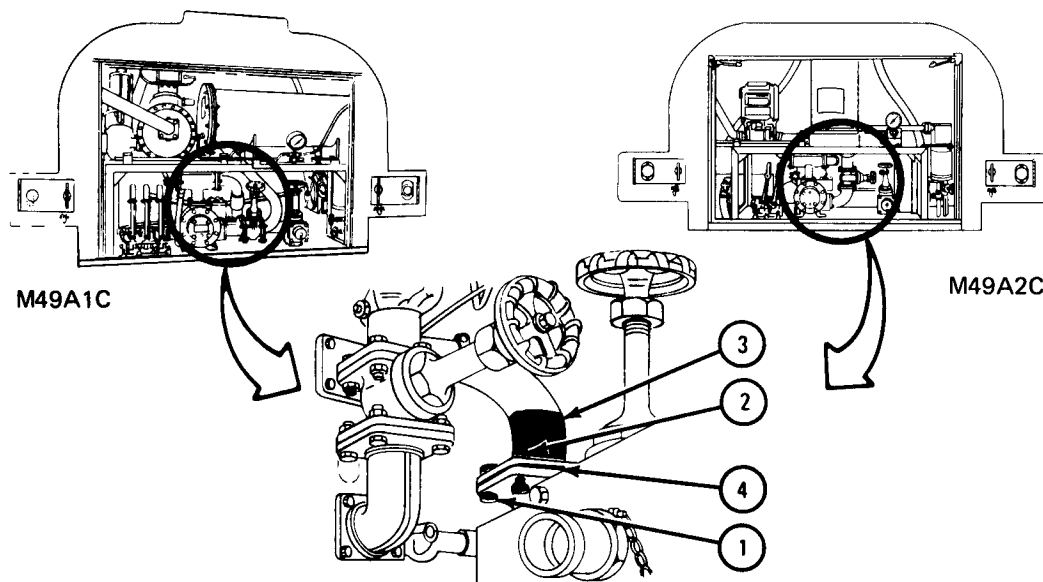

TA 046444

FRAME 2

1. Using 3/4-inch wrench and 3/8-inch socket and ratchet, unscrew and take out four screws (1). Take off four lockwashers (2).
2. Take off pipe (3).
3. Take off and throw away gasket (4).

GO TO FRAME 3

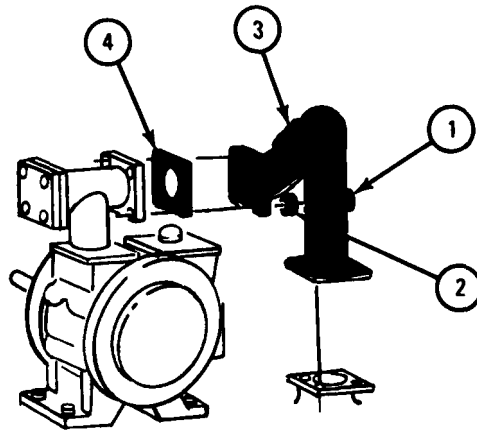

TA 046445

## FRAME 3

1. Using screwdriver, loosen nuts (1) on clamps (2) until clamps are loose on hose (3).
2. Push clamps (2) down onto lower pipe (4).
3. Take upper pipe (5) out of hose (3).
4. Take hose (3) off lower pipe (4). Throw away hose.

END OF TASK

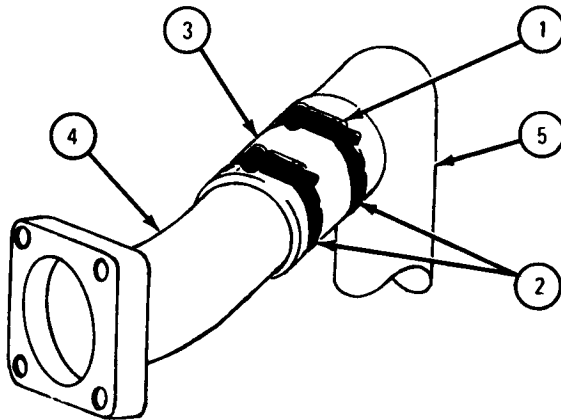

TA 046446

b. Replacement.

FRAME 1

1. Put two clamps (1) on lower pipe (2).
2. Using diesel fuel, lubricate inside of hose (3).
3. Put hose (3) on lower pipe (2).
4. Put upper pipe (4) in hose (3).
5. Take one clamp (1) from lower pipe (2) and put it so it holds hose (1) on upper pipe (4). Tighten nut (5) just enough to hold clamp on hose.
6. Take other clamp (1) from lower pipe (2) and put it so it holds hose (3) on lower pipe. Using screwdriver, tighten nut (6) enough so there is no leak of fuel from hose.

GO TO FRAME 2

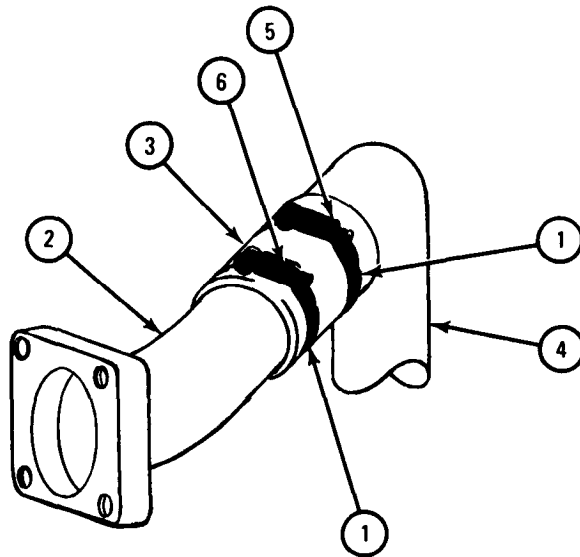

TA 046447



## FRAME 2

1. Put gasket (1) on flange (2), lining up screw holes.
2. Put pipe (3) on gasket (1) as shown, lining up screw holes.
3. Using 3/4-inch wrenches, screw in and tighten four screws (4) and four nuts (5).

GO TO FRAME 3

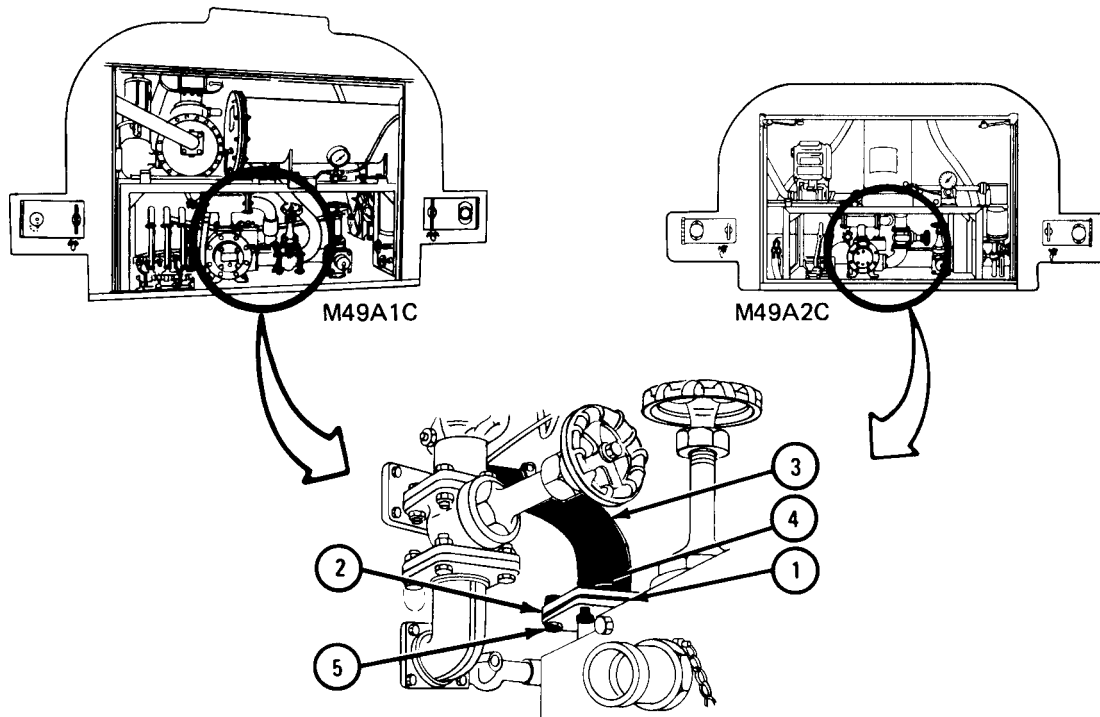

TA 046448

FRAME 3

1. Put pipe (1) so pipe flange (2) lines up with flange (3).
2. Put gasket (4) between pipe flange (2) and flange (3), lining up screw holes.
3. Put lockwasher (5) on each of four screws (6). Using 3/4-inch wrench and 3/8-inch socket and ratchet, screw in and tighten four screws.
4. Using screwdriver, tighten nut (7) on clamp (8).
5. Close fuel truck rear compartment doors.

END OF TASK

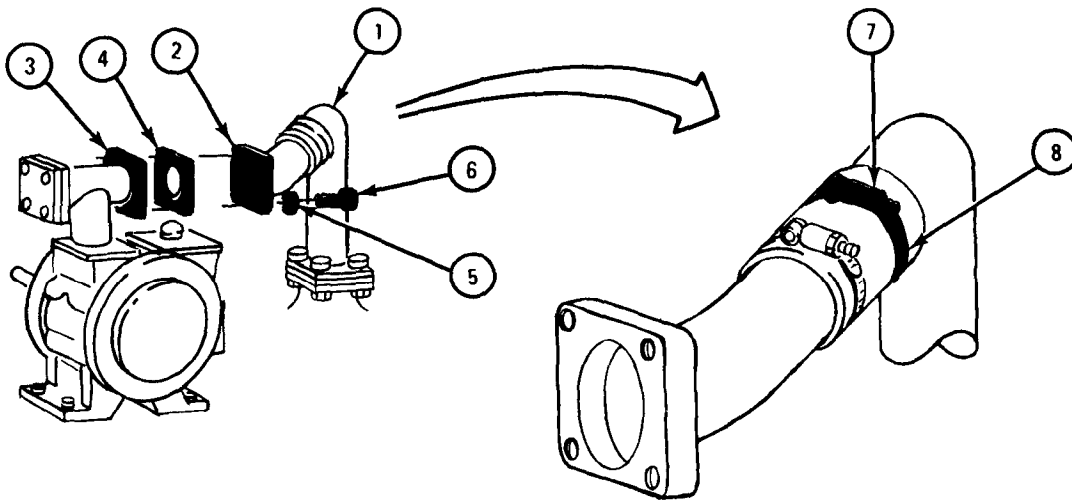

TA 046449

18-39. WATER SEGREGATOR UNIT REMOVAL, REPAIR, AND REPLACEMENT  
(TRUCK M49A1C).

TOOLS: Open end wrench set, pn GGG-W-636  
10-inch pipe wrench (2)  
Putty knife

SUPPLIES: Solvent, dry cleaning, type II (SD-2), Fed. Spec P-D-680  
Liquid gasket cement, MIL-A-46106A  
Segregator input tube gasket  
Segregator output tube gasket  
Automatic dump valve housing gasket  
5-gallon open top container

PERSONNEL: One

EQUIPMENT CONDITION: Truck parked, engine off, handbrake set.

a. Removal.

FRAME 1

WARNING

Smoking, sparks, or open flame are not allowed within 50 feet of working area during this task. Fuel could catch fire or explode, causing serious injury to personnel and damage to equipment.

1. Open rear compartment doors (1).
2. Put container under two drain valves (2).
3. Turn two drain valves (2) to the right to open position and drain liquid into container.
4. Take away container and put liquid in approved disposal area.

GO TO FRAME 2

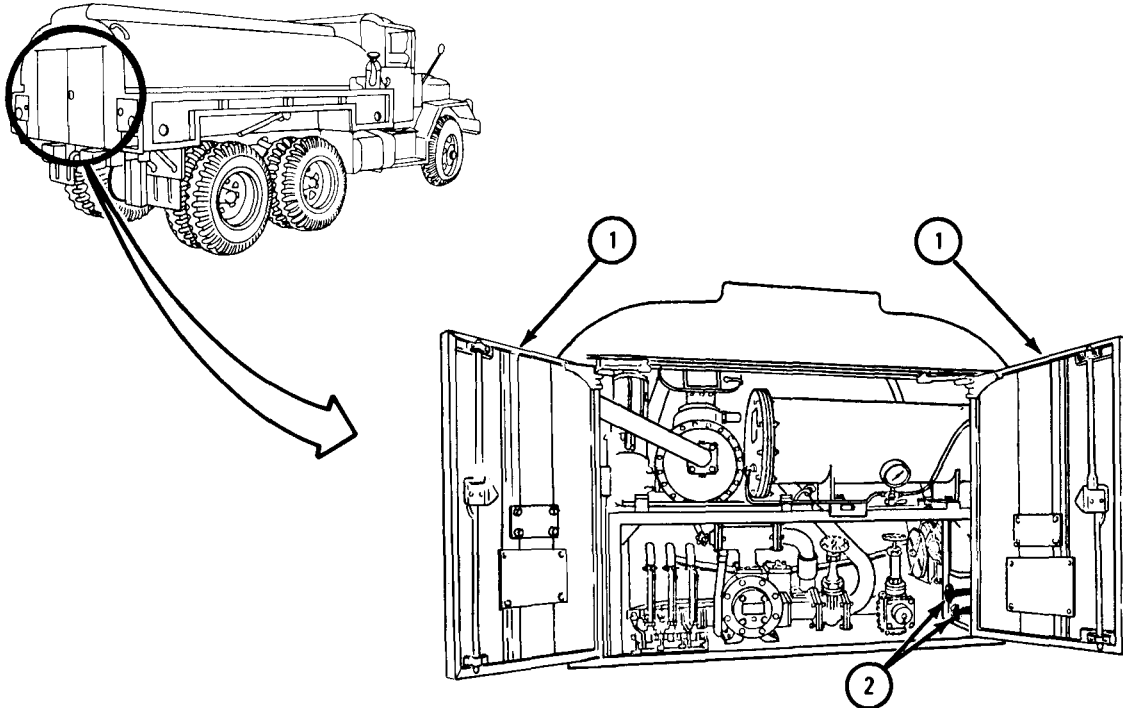

TA 051733

## FRAME 2

1. Using pipe wrenches, hold larger valve (1) and from underneath truck, unscrew and take out pipe (2).
2. Using pipe wrenches, hold smaller valve (3) and from underneath truck, unscrew and take out nipple (4).
3. Using pipe wrench, unscrew and take out nipple (5) with valve (3).
4. Using pipe wrench, unscrew and take out nipple (6) with valve (1).

GO TO FRAME 3

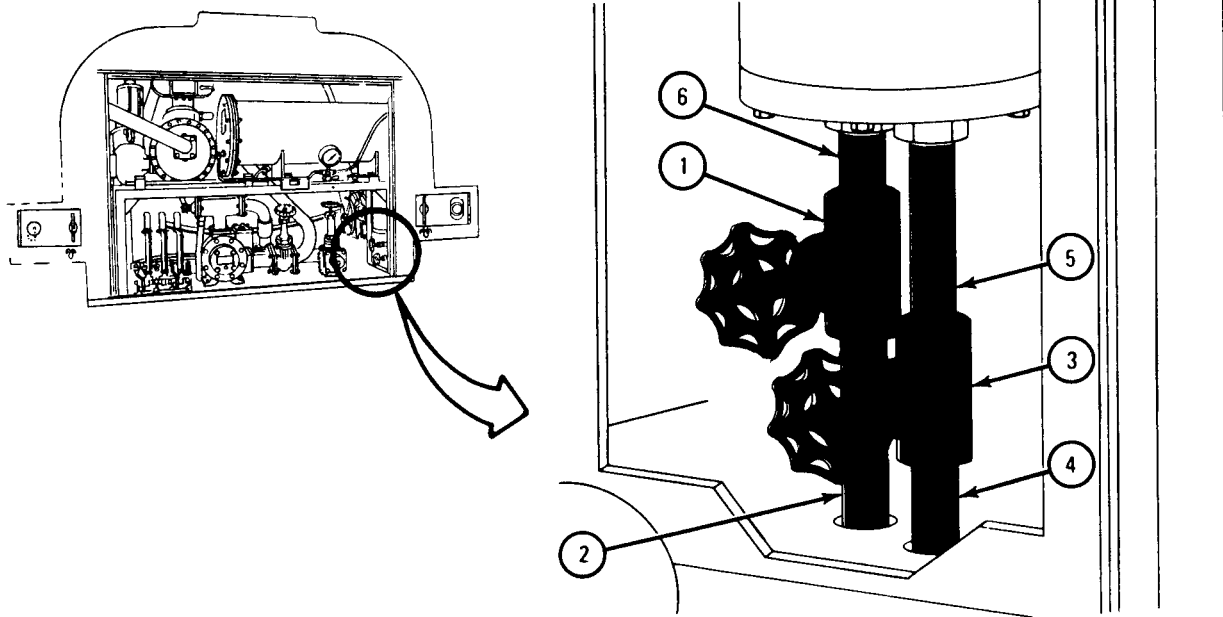

TA051734

FRAME 3

1. Using wrenches, unscrew and take out four capscrews (1), lockwashers (2), and nuts (3).

GO TO FRAME 4

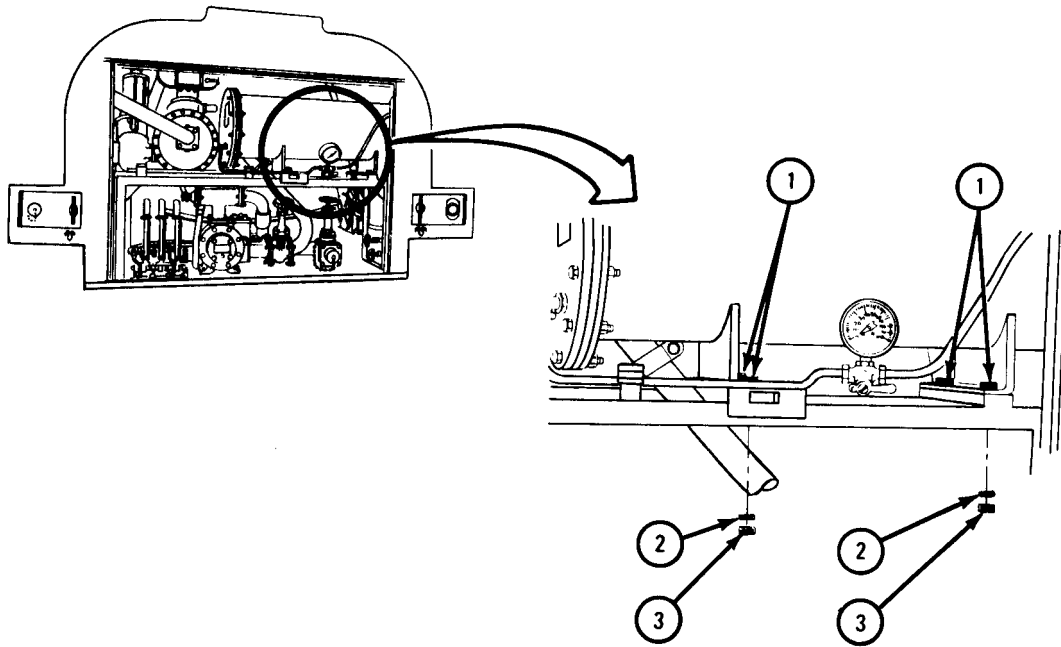

TA 051749

## FRAME 4

1. Working at inlet pipe (1) using wrenches, unscrew and take off two nuts (2) and capscrews (3). Take off clamp halves (4) and gasket (5). Throw away gasket.
2. Working at outlet pipe (6) using wrenches, unscrew and take off two nuts (2) and capscrews (3). Take off clamp halves (4) and gasket (5). Throw away gasket.
3. Pull left end of segregator unit (7) out of truck compartment. Drop left end down while lifting right end up and out of compartment.

END OF TASK

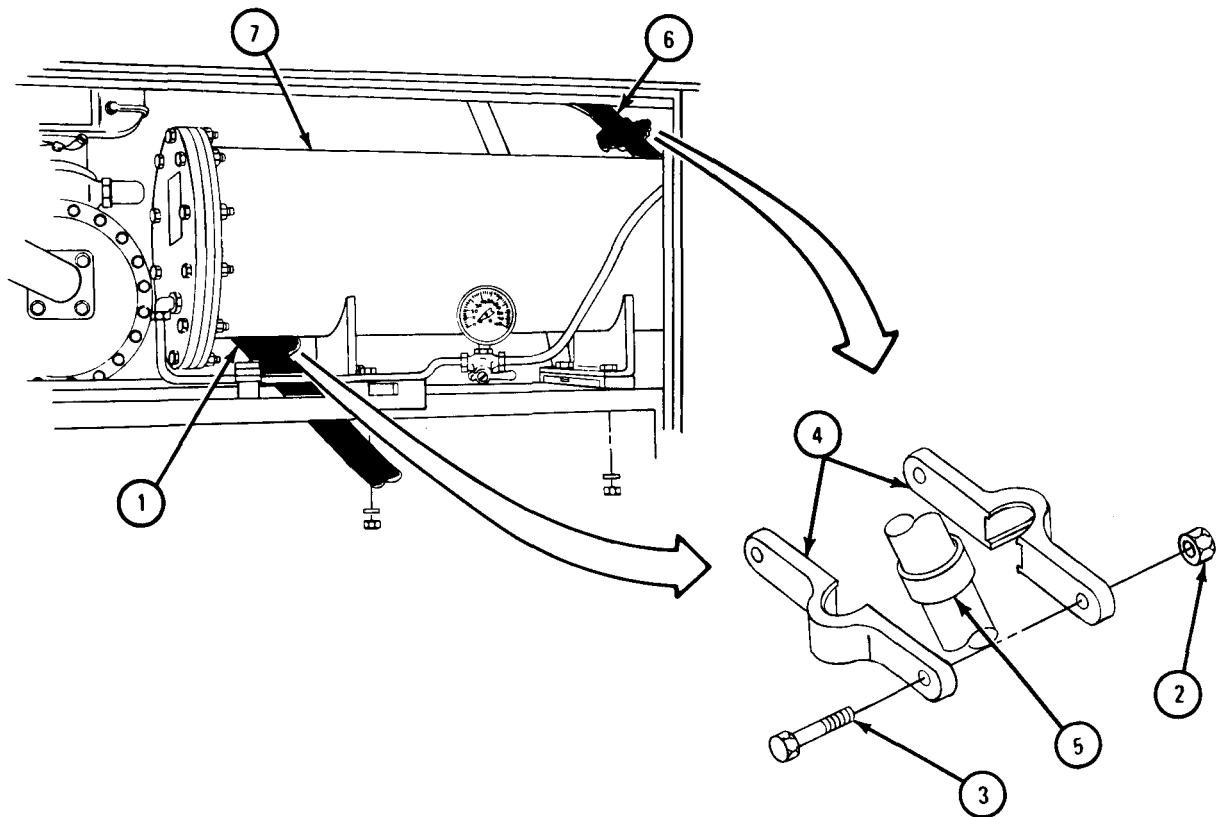

TA051750

b. Repair.

FRAME 1

1. Place water segregator (1) on workbench.

NOTE

Before taking off plate (2), check position of fittings on bottom of plate so that it can be put back in same position.

2. Using wrench, unscrew and take out eight capscrews (3).
3. Carefully pull out plate (2), gasket (4), and automatic dump valve assembly (5). Throw away gasket.

GO TO FRAME 2

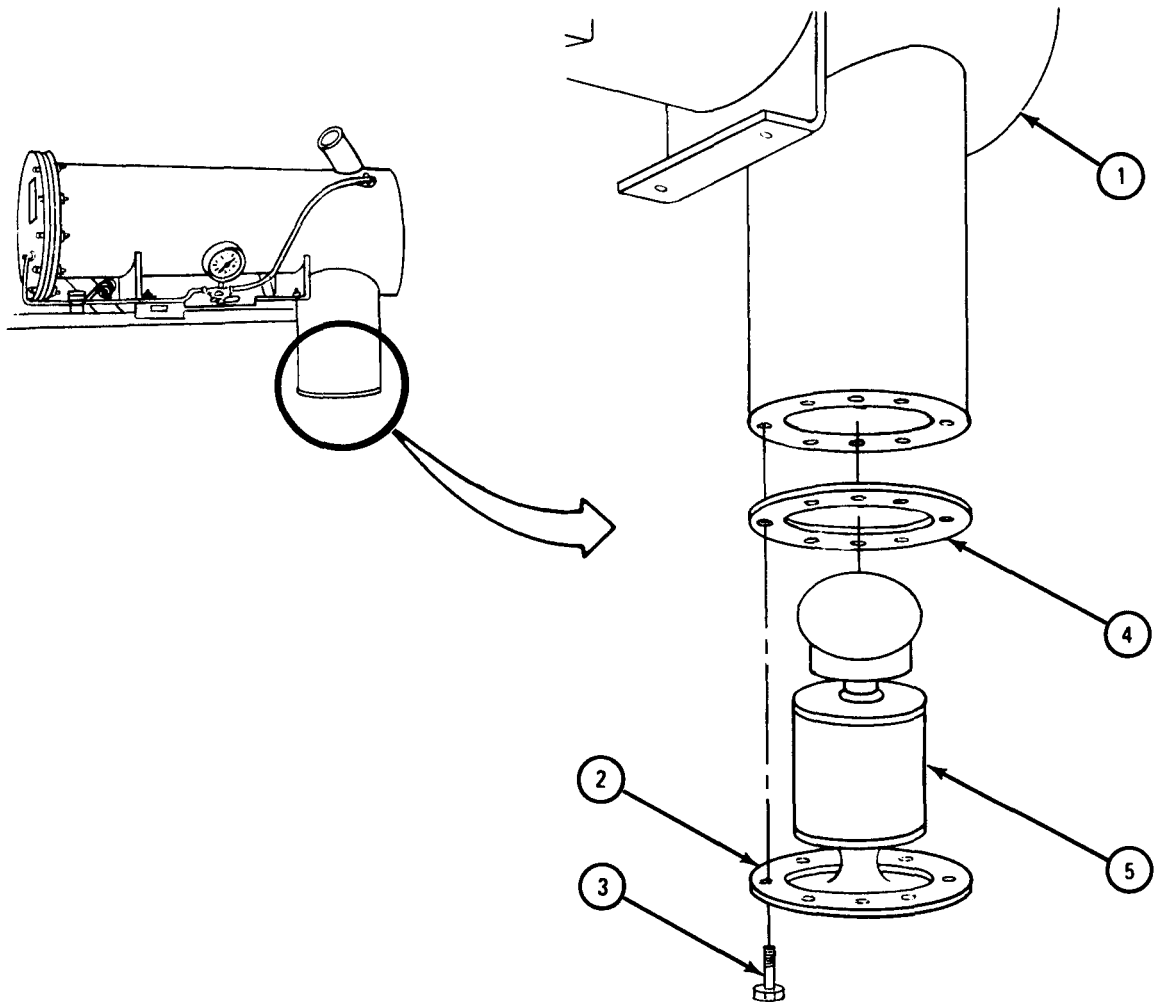

TA084030



## FRAME 2

- Using putty knife, clean flanges of plate (1) and automatic dump valve housing (2).

WARNING

Dry cleaning solvent is flammable. Do not use near an open flame. Keep a fire extinguisher nearby when solvent is used. Use only in well-ventilated places. Failure to do this may result in injury to personnel and damage to equipment.

- Using solvent, clean automatic dump valve housing (2) and all parts of automatic dump valve assembly (3).
- Check that float (4) can move up and down freely.
- Check that moving parts of automatic dump valve assembly (3) are not worn or damaged. Get new parts if needed.
- Put a coating of liquid gasket cement on flanges of automatic dump valve housing (2) and plate (1).
- Place gasket (5) on plate (1) and align holes.
- Put plate (1) with gasket (5) to automatic dump valve housing (2) as noted.
- Using wrench, screw in and tighten eight screws (6).

END OF TASK

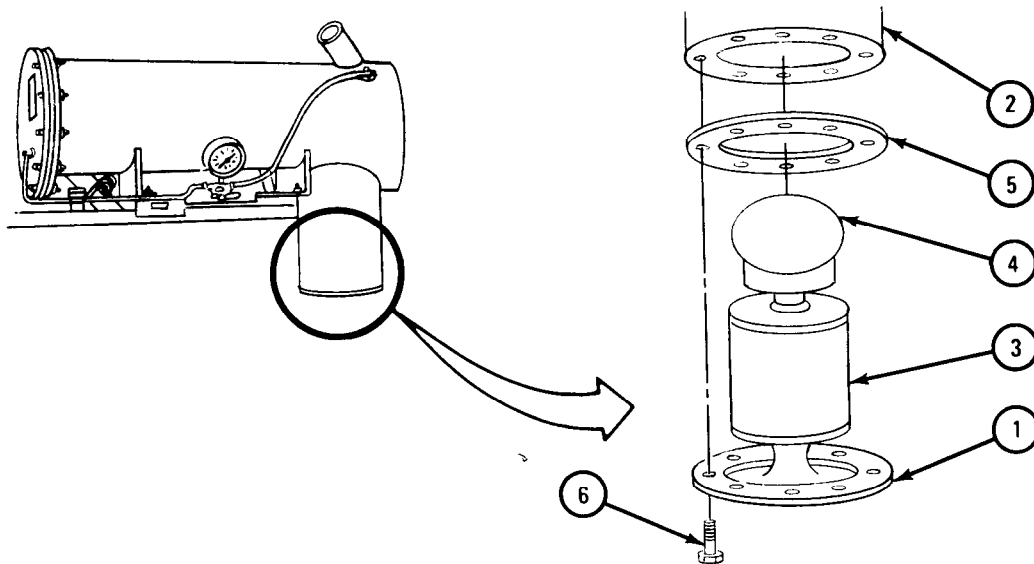

TA084031

c. Replacement.

FRAME 1

1. Lift segregator unit (1), with right end higher and put it in compartment. Put right end down in place, then push left end in place on two brackets (2).
2. Working at inlet pipe (3), put gasket (4), clamp halves (5), and two capscrews (6) in place. Using wrenches, screw on and tighten two nuts (7).
3. Working at outlet pipe (8), put gasket (4), clamp halves (5), and two capscrews (6) in place. Using wrenches, screw on and tighten two nuts (7).

GO TO FRAME 2

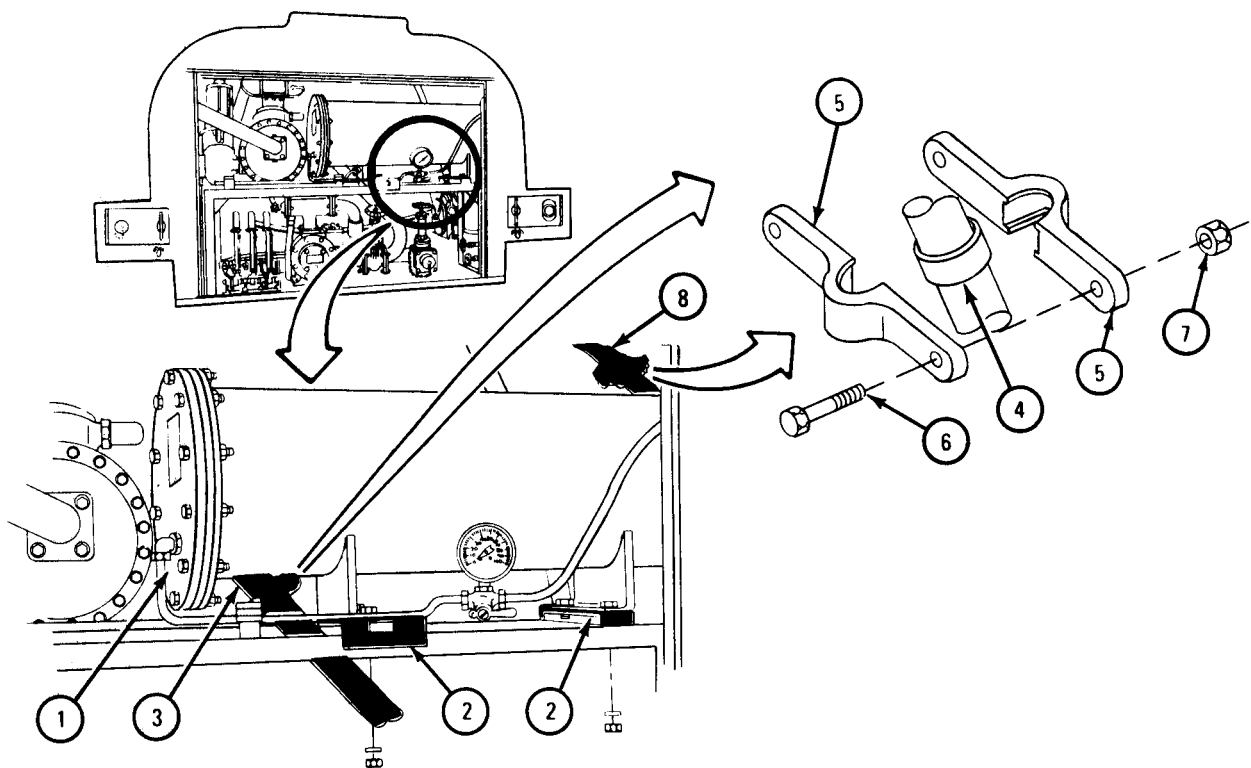

TA051751

## FRAME 2

1. Aline holes in segregator unit (1) with holes in bracket (2).
2. Put in four capscrews (3) and lockwashers (4). (Using wrenches, screw on and tighten four nuts (5)).

GO TO FRAME 3

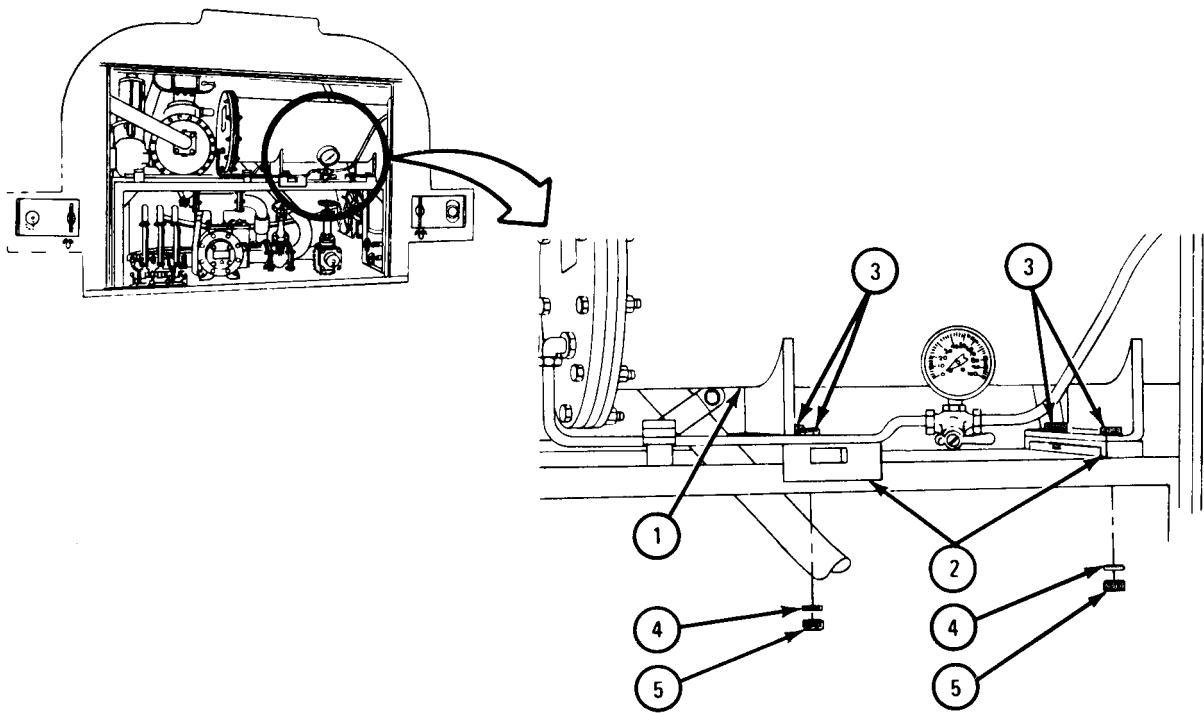

TA 051752

FRAME 3

1. Using pipe wrench, screw nipple (1) with larger valve (2) into larger fitting on automatic dump valve housing (3). Tighten nipple (1) so that valve handle is toward left side of truck.
2. Using pipe wrench, screw nipple (4) with smaller valve (5) into smaller fitting on automatic dump valve housing (3). Tighten nipple (4) so that valve handle is toward left side of truck.
3. From underneath truck, push nipple (6) up into place through smaller hole in compartment floor (7).
4. Using pipe wrenches, hold valve (5) and screw in and tighten nipple (6).
5. From underneath truck, push pipe (8) up into place through larger hole in compartment floor (7).
6. Using pipe wrenches, hold valve (2) and screw in and tighten pipe (8).
7. Turn handles of valves (2 and 5) right to closed position.
8. Close rear compartment doors.

END OF TASK

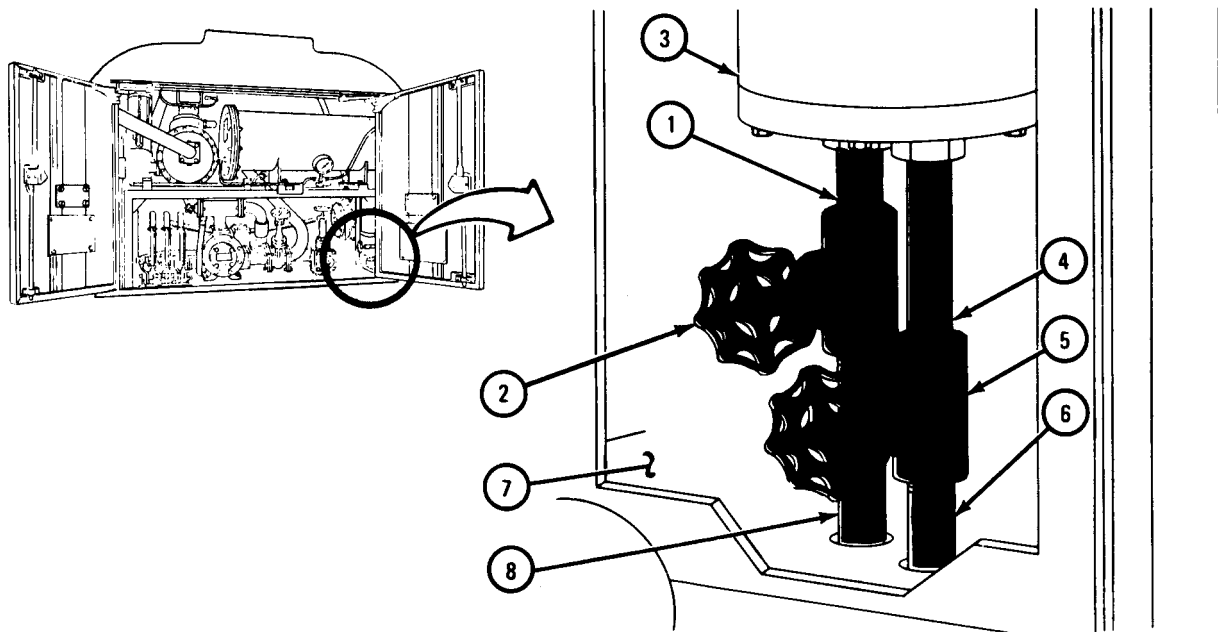

TA051748

## 18-40. WATER SEGREGATOR UNIT SERVICE (TRUCK M46A2C).

WARNING

Smoking, sparks, or open flame are not allowed within 50 feet of work area during this task. Fuel may burn, causing explosion, injury to personnel, and damage to equipment.

TOOLS: None

SUPPLIES: Container

PERSONNEL: One

EQUIPMENT CONDITION: Truck parked, engine off, handbrake set.

## FRAME 1

1. Open truck rear compartment doors.
2. Put container under drain tube (1).
3. Turn drain valve (2) to the left. When water stops draining from drain tube (1), turn drain valve to the right to close.
4. Close truck rear compartment doors and take away container.

END OF TASK

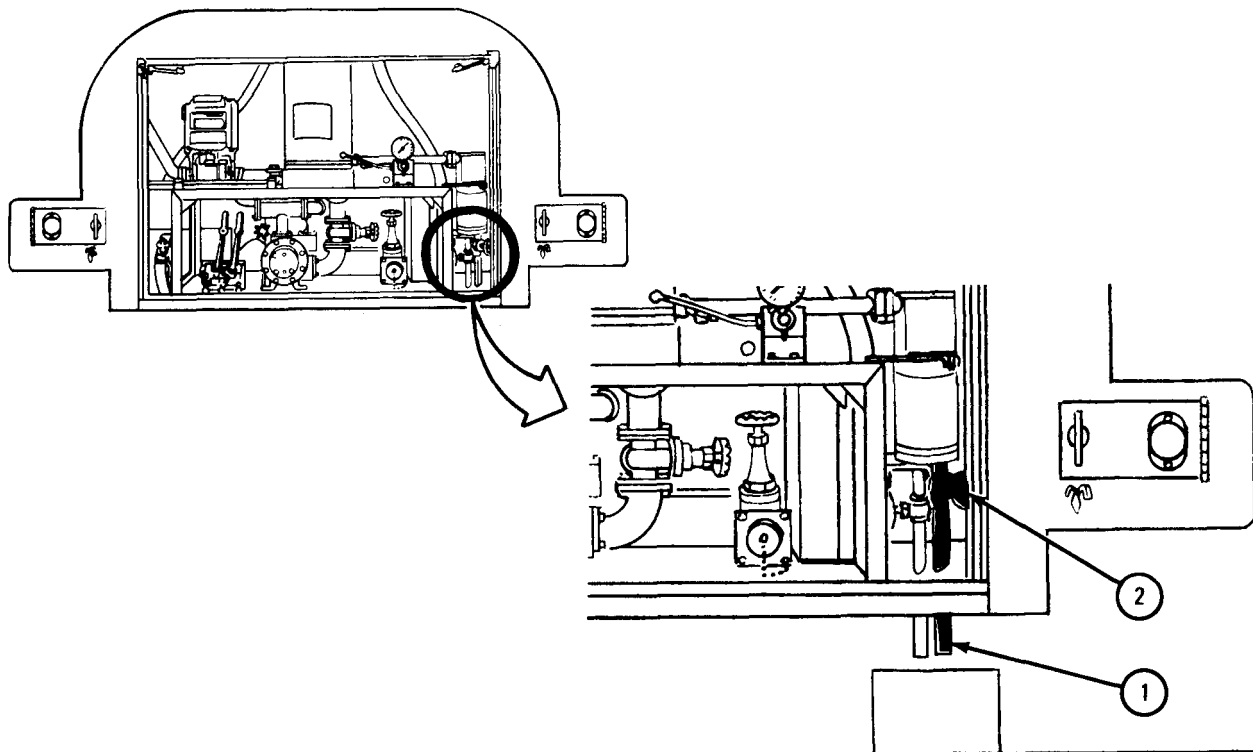

TA 084048

18-41. WATER SEGREGATOR FILTER ELEMENT REMOVAL AND REPLACEMENT  
(TRUCK M49A1C).

TOOLS: Open end wrench set, pn GGG-W-636  
10-inch pipe wrench  
Torque wrench, 25-pound foot capacity

SUPPLIES: Filter element  
Filter element performed packing  
Filter element gasket  
Water segregator and plate gasket  
Water segregator output tube gasket  
Water segregator input tube gasket  
Solvent, dry cleaning, type II (SD-2). Fed. Spec P-D-680  
5-gallon open top container

PERSONNEL: One

EQUIPMENT CONDITION: Truck parked, engine off, handbrake set.

a. Removal.

FRAME 1

WARNING

Smoking, sparks or open flame not allowed within 50 feet of working area during this task. Fuel could catch fire or explode, causing serious injury to personnel and damage to equipment.

1. Open compartment doors (1).
2. Put container under two drain valves (2).
3. Open two drain valves (2) and drain liquid into container.
4. Take away container and put liquid in approved disposal area.

GO TO FRAME 2

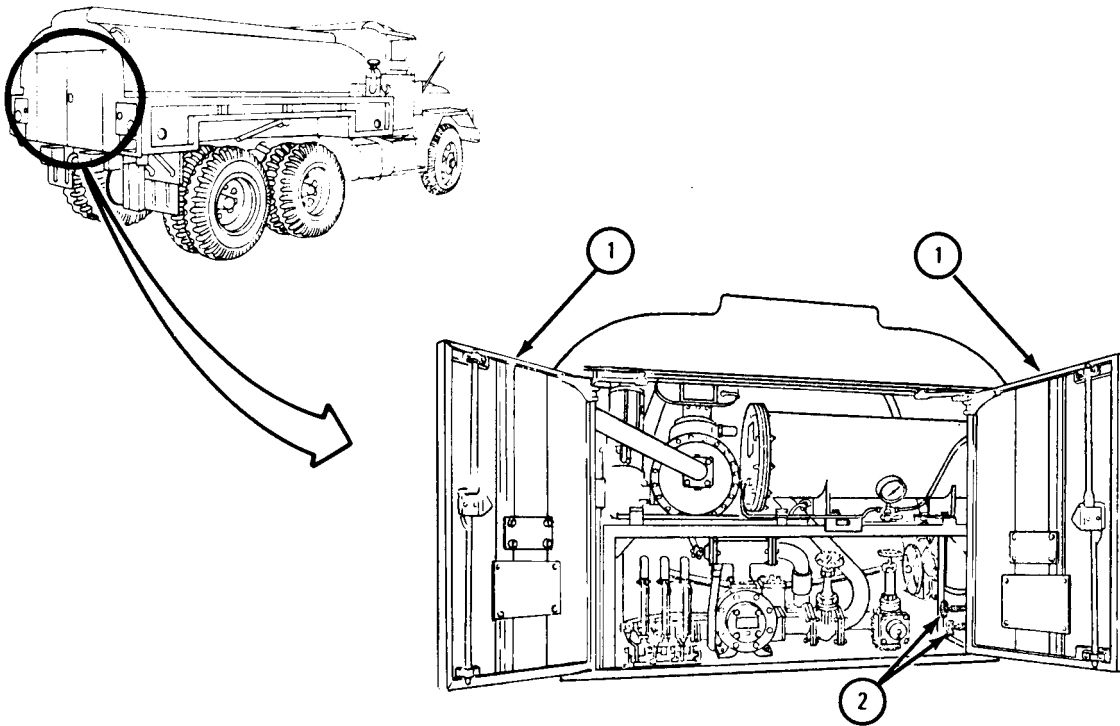

TA 051733

FRAME 2

1. Using pipe wrenches, hold larger valve (1) and from underneath truck, unscrew and take out pipe (2).
2. Using pipe wrenches, hold smaller valve (3) and from underneath truck, unscrew and take out nipple (4).

GO TO FRAME 3

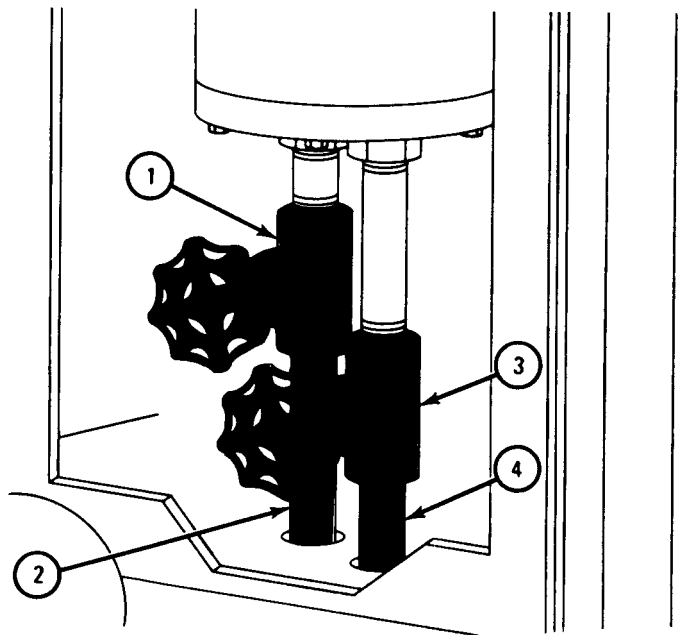
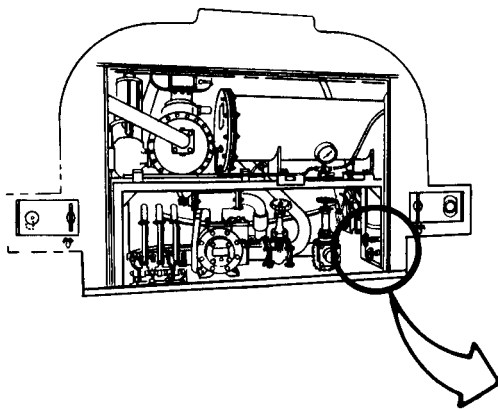

TA084040



## FRAME 3

1. Using wrench, unscrew coupling nut (1).
2. Using wrench, unscrew coupling nut (2) and take off tube (3).

GO TO FRAME 4

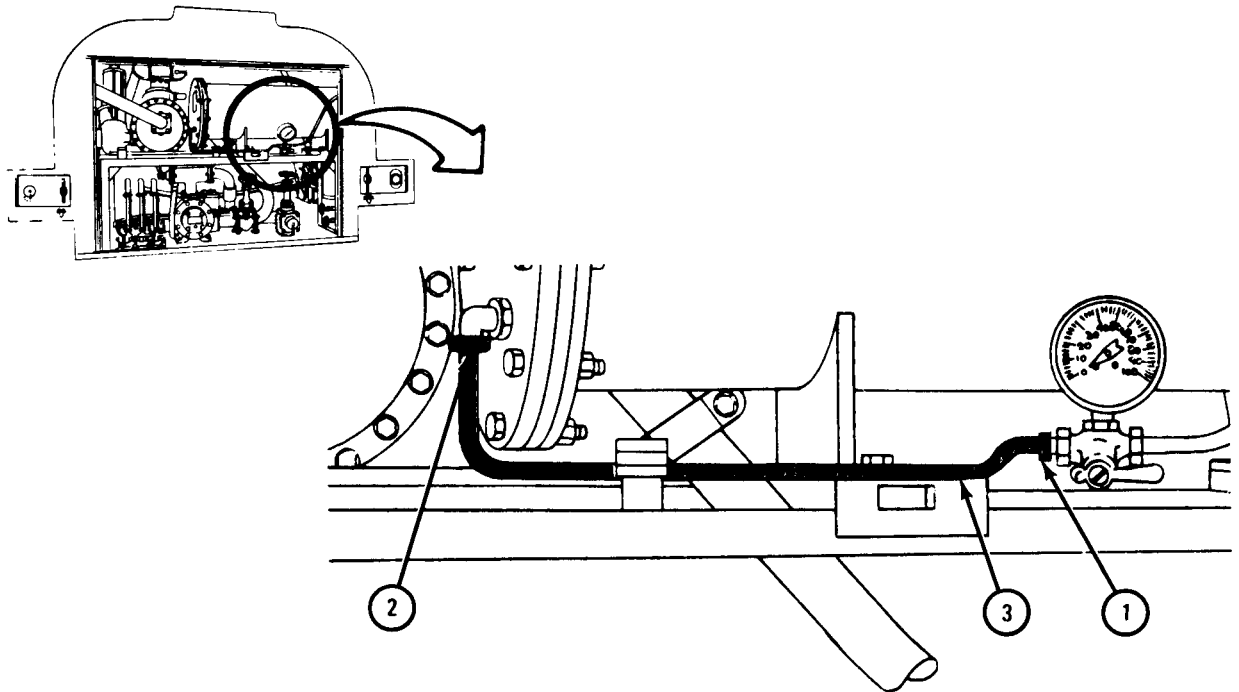

TA 051735

FRAME 4

1. Using wrenches, loosen two capscrews (1).
2. Using wrenches, unscrew and take out two capscrews (2), lockwashers (3), and nuts (4).

GO TO FRAME 5

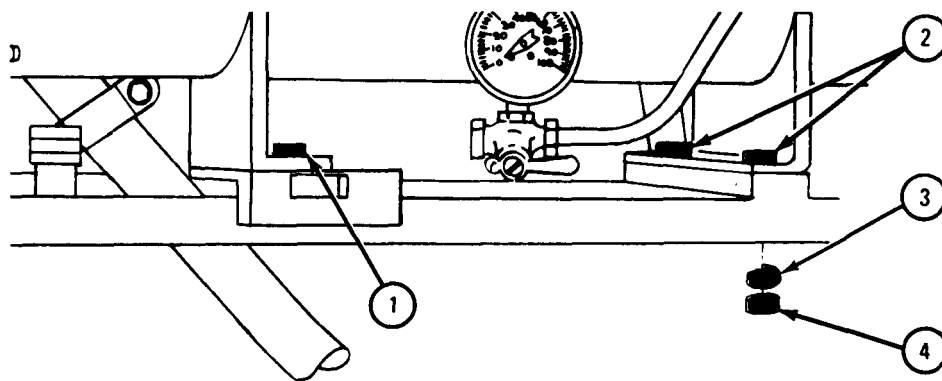

TA 051736

## FRAME 5

1. Working at inlet pipe (1) using wrenches, unscrew and take off two nuts (2) and capscrews (3). Take off clamp halves (4) and gasket (5). Throw away gasket.
2. Working at outlet pipe (6) using wrenches, unscrew and take off two nuts (2) and capscrews (3). Take off clamp halves (4) and gasket (5). Throw away gasket.

GO TO FRAME 6

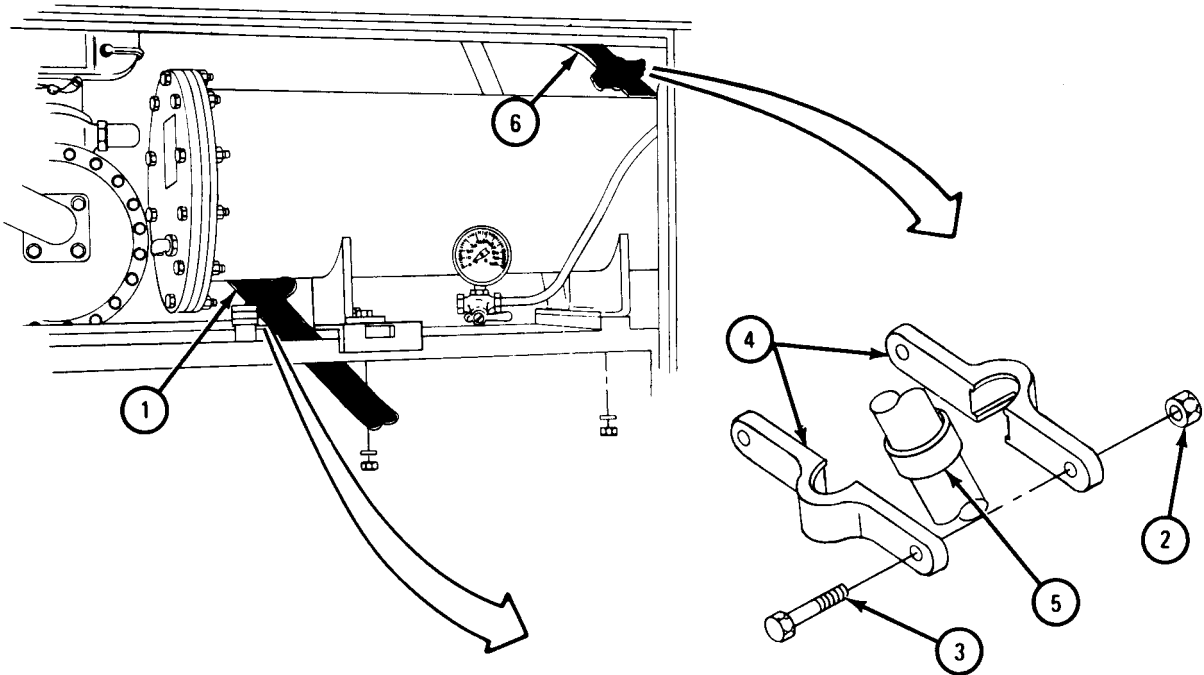

TA 051737

FRAME 6

1. Slide left side of segregator unit (1) outward to end of slots in bracket (2).
2. Using wrenches, unscrew and take off 12 nuts with washers (3). Take out 12 capscrews (4)
3. Take off plate (5) and gasket (6). Throw away gasket.

GO TO FRAME 7

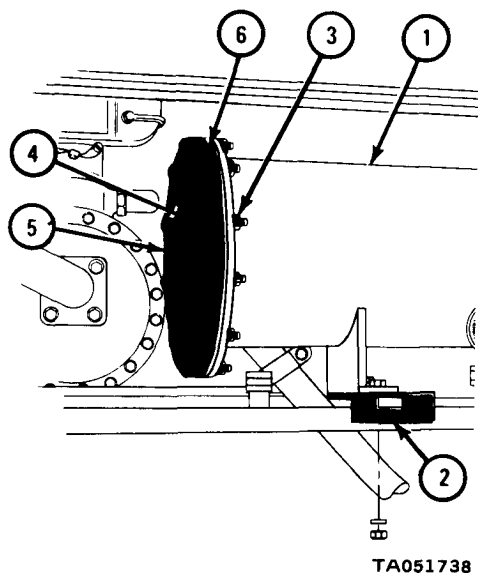

## FRAME 7

1. Using wrench, unscrew and take off three nuts with flat washers (1).
2. Take out cartridge assembly (2).

GO TO FRAME 8

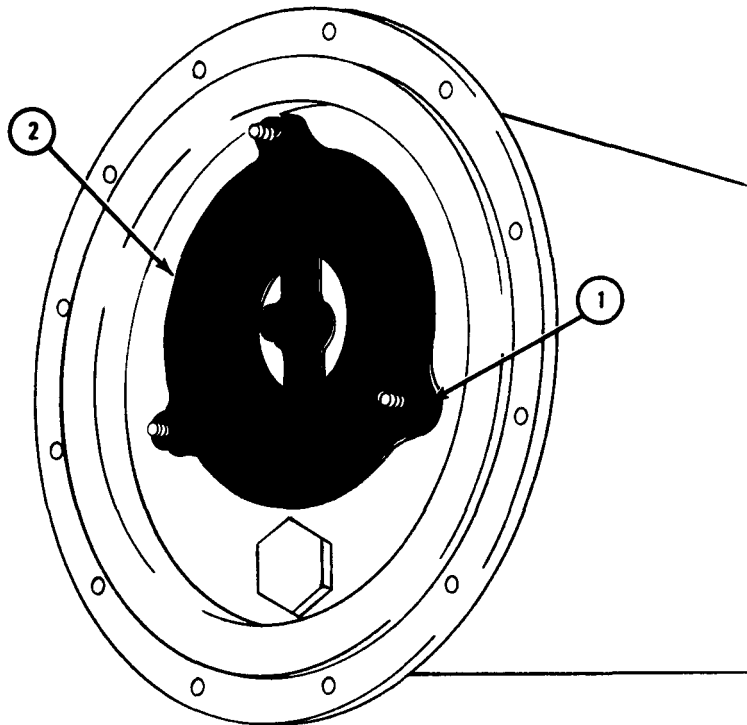

TA 051739

FRAME 8

1. Using wrench, unscrew and take off nut (1), flat washer (2), gasket (3), and retainer (4).
2. Take rod and cap assembly (5) out of filter element (6). Throw element away in approved disposal area.
3. Take preformed packing (7) out of groove in rod and cap assembly (5) and throw it away.

END OF TASK

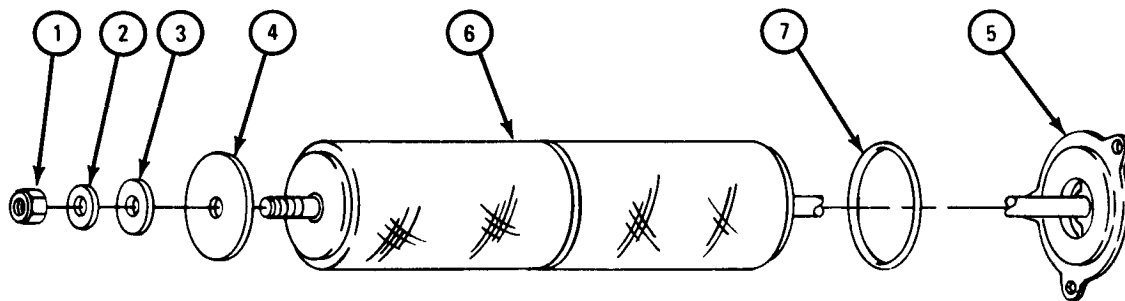

TA 051740

b. Replacement.

FRAME 1

WARNING

Dry cleaning solvent is flammable. Do not use near an open flame. Keep a fire extinguisher nearby when solvent is used. Use only in well-ventilated places. Failure to do this may result in injury to personnel and damage to equipment.

1. Using solvent, clean all parts.
2. Put preformed packing (1) in place in groove on rod and cap assembly (2).
3. Put filter element (3) in place on rod and cap assembly (2). Put retainer (4), gasket (5), and flat washer (6) on threaded end of rod.
4. Using torque wrench, screw on and tighten nut (7) to 5 pound-feet.

GO TO FRAME 2

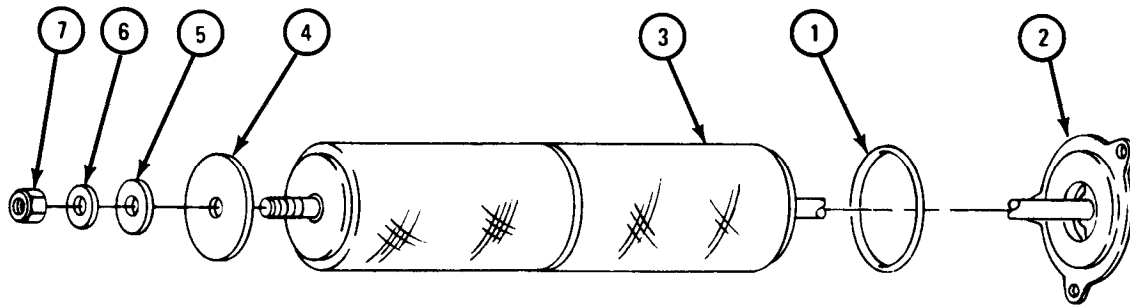

TA 051741

FRAME 2

1. Put cartridge assembly (1) in place on segregator unit studs (2) with cap cross bar (3) as shown.

GO TO FRAME 3

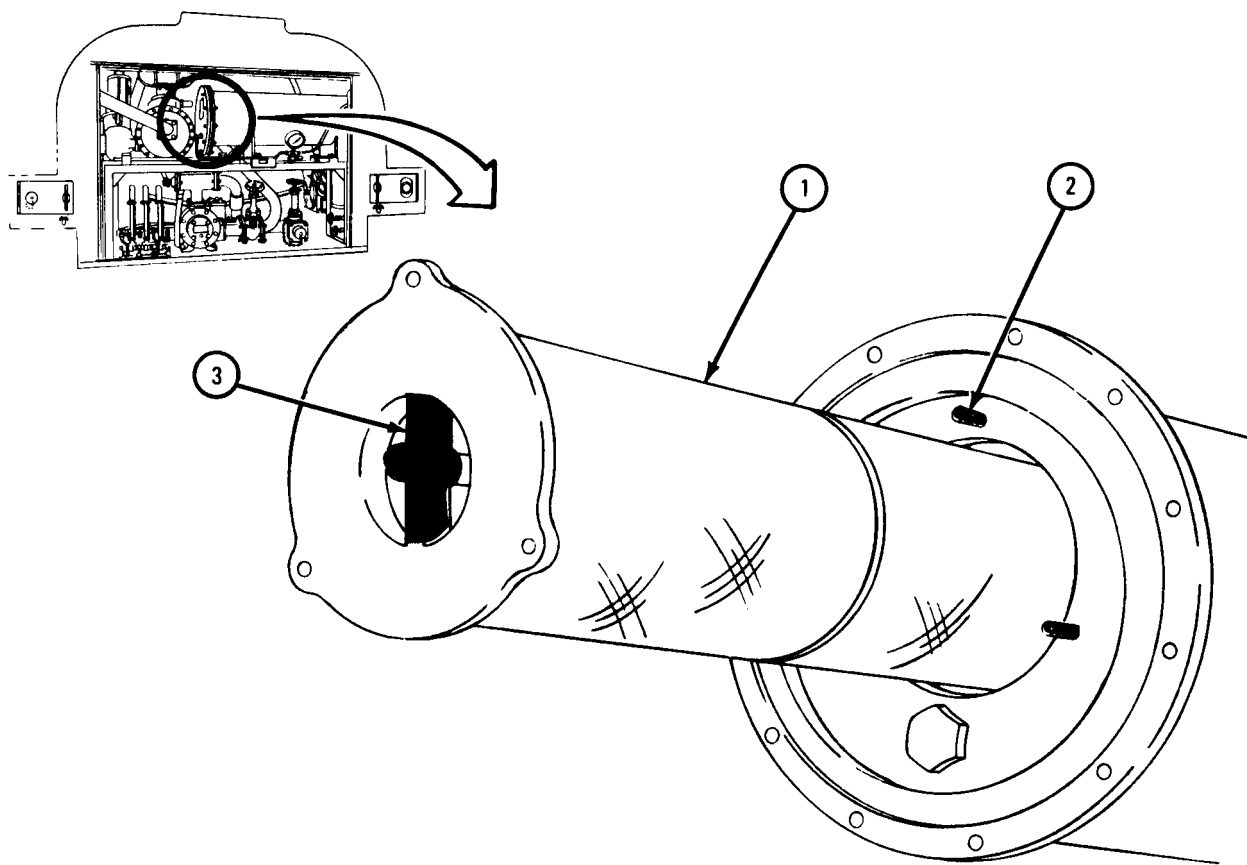

TA 051742



## FRAME 3

1. Using torque wrench, screw on and tighten three self locking nuts (1) with flat washers (2) to 25 pound-feet.

GO TO FRAME 4

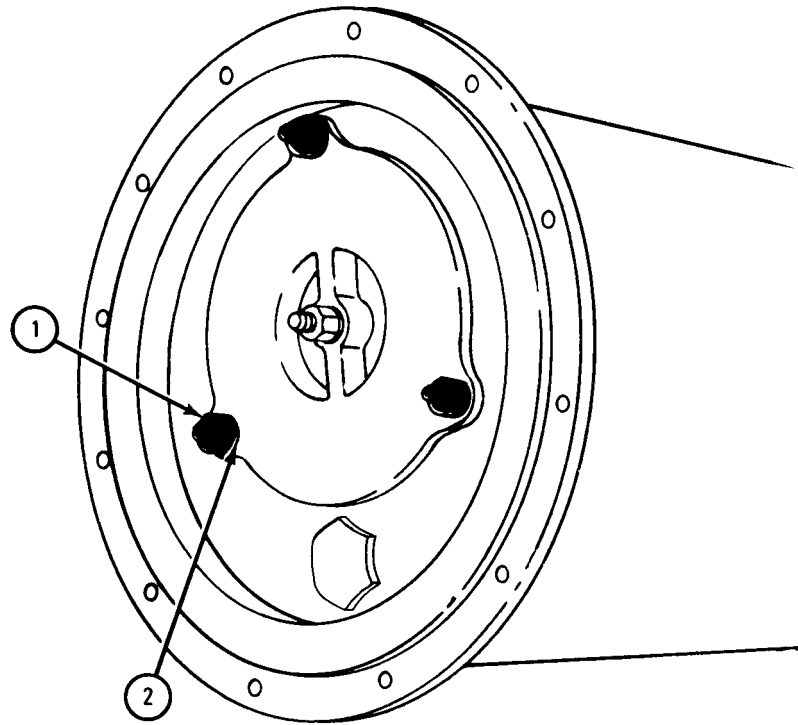

TA 051743

FRAME 4

1. Put gasket (1) and plate (2) in place.
2. Put in 12 capscrews (3).
3. Using torque wrench, screw on and tighten self locking nuts with flat washers (4) to 25 pound-feet.
4. Slide segregator unit (5) back in truck.

GO TO FRAME 5

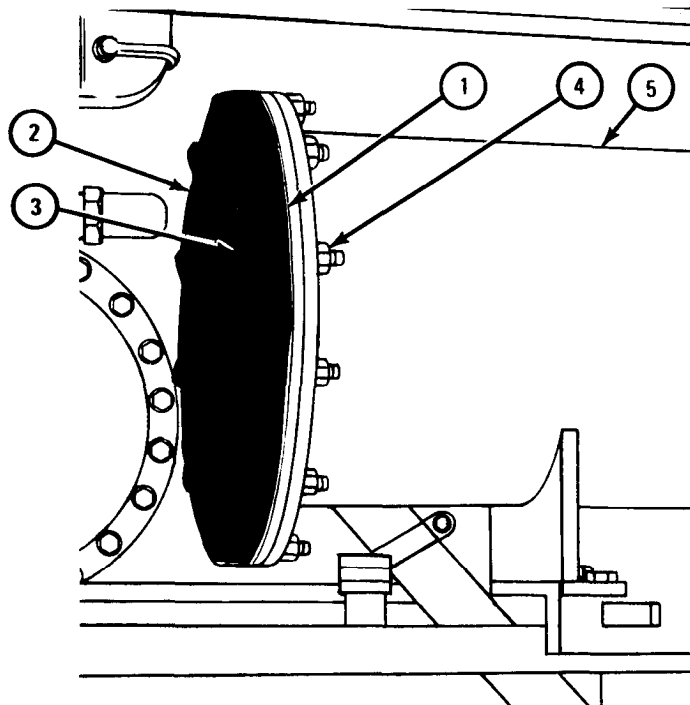

TA 051744

## FRAME 5

1. Working at outlet tube (1), put gasket (2) and clamp halves (3) in place. Put in two capscrews (4) and using wrenches, screw on and tighten two nuts (5).
2. Working at inlet tube (6), put gasket (2) and clamp halves (3) in place. Put in two capscrews (4) and using wrenches, screw on and tighten two nuts (5).

GO TO FRAME 6

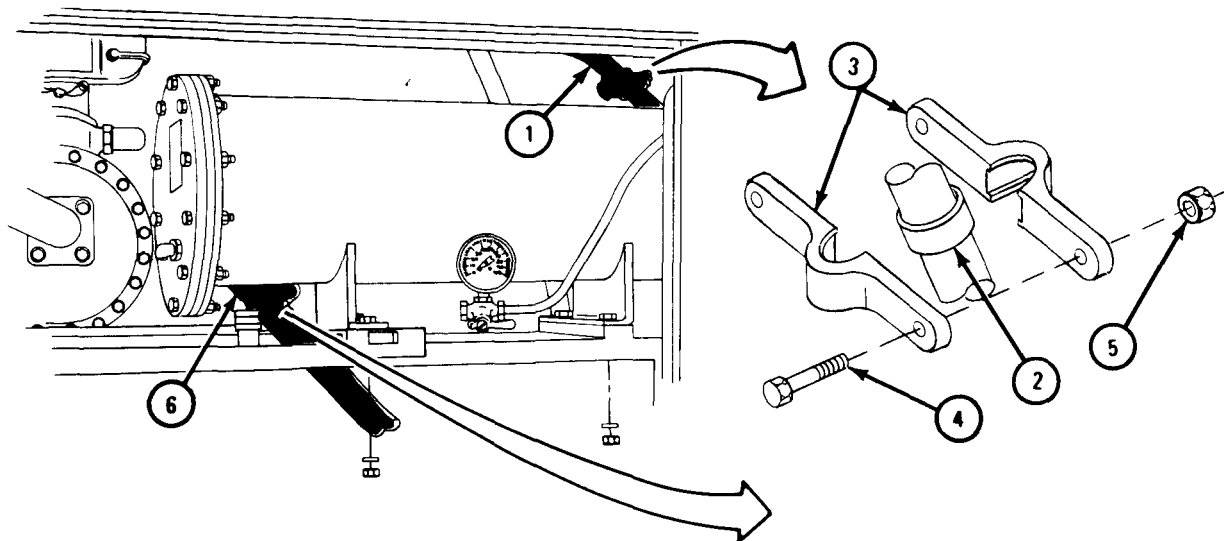

TA 051745

FRAME 6

1. Put in two capscrews (1) and lockwashers (2). Using wrenches, screw on and tighten two nuts (3).
2. Using wrenches, tighten two capscrews (4).

GO TO FRAME 7

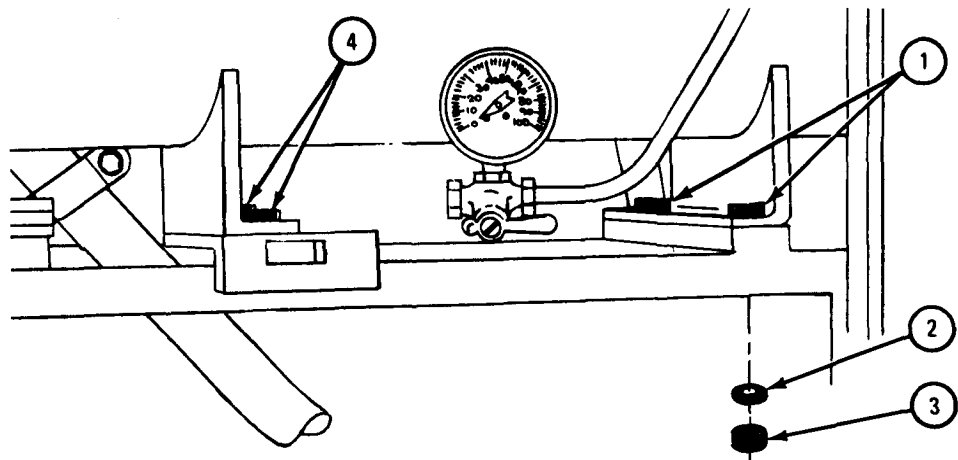

TA 051746

## FRAME 7

1. Put end of tube (1) in place and start coupling nut (2) into fitting (3).  
Put other end of tube (1) in place and start coupling nut (4) into elbow (5).
2. Using wrench, screw on and tighten coupling nut (4).
3. Using wrench, screw on and tighten coupling nut (2).

GO TO FRAME 8

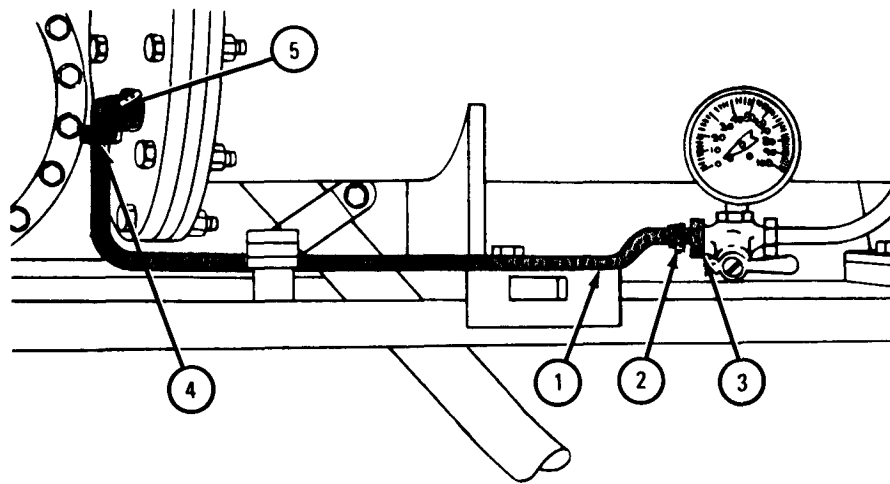

TA 051747

FRAME 8

1. From underneath truck, push nipple (1) up into place through smaller hole in compartment floor (2).
2. Using pipe wrenches, hold valve (3) and screw in and tighten nipple (1).
3. From underneath truck, push pipe (4) up into place through larger hole in compartment floor (2).
4. Using pipe wrenches, hold valve (5) and screw in and tighten pipe (4).
5. Turn handles of valves (3 and 5) right to closed position.
6. Close rear compartment doors.

END OF TASK

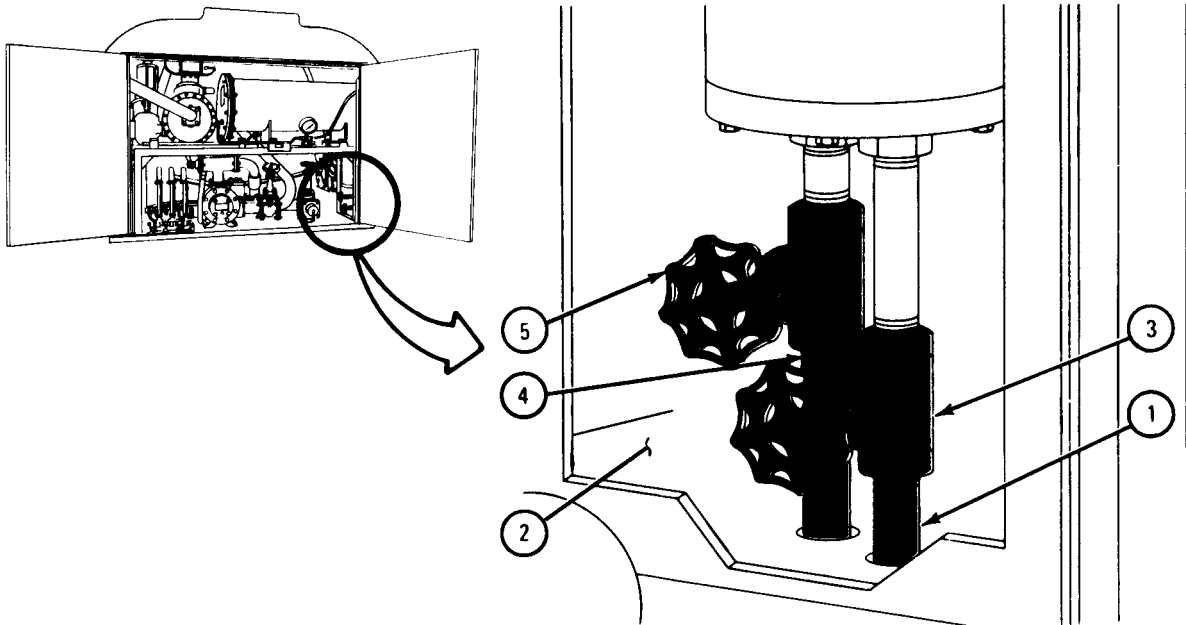

TA 084041

18-42. WATER SEGREGATOR FILTER AND GO/NO-GO FUSES REMOVAL AND REPLACEMENT (TRUCK M49A2C).

TOOLS: 9/16-inch open end wrench (2)      7/16-inch wrench  
 13/16-inch open end wrench              Eye shields  
 1/2-inch open end wrench

SUPPLIES: Manhole cover gasket  
 Filter (3)  
 GO/NO-GO fuses  
 Fuel (type normally carried in tanker)  
 Compressed air, 30 psi max

PERSONNEL: One

EQUIPMENT CONDITION: Truck parked, engine off, handbrake set.

WARNING

Smoking, sparks or open flame are not allowed within 50 feet of fuel truck during this task. Fuel may burn, causing explosion, injury to personnel, and damage to equipment.

a. Removal.

FRAME 1

1. Using 9/16-inch wrenches, unscrew and take out nut (1) and bolt (2).
2. Take off clamp ring (3).
3. Take off manhole cover (4) and gasket (5).

GO TO FRAME 2

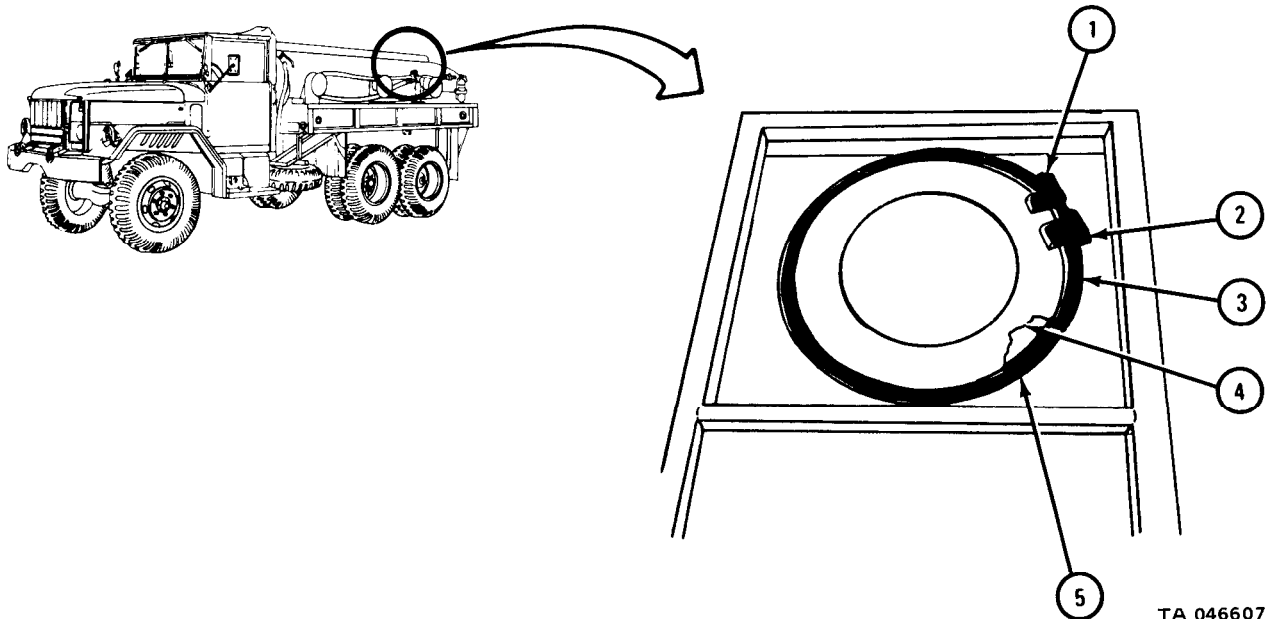

FRAME 2

1. Using 13/16-inch wrench, unscrew two coupling nuts (1). Take off air vent line (2).
2. Using 1/2-inch wrench, unscrew and take off nut (3). Take off clamp ring (4).
3. Take off cover (5).
4. Take off gasket (6). Throw away gasket.

GO TO FRAME 3

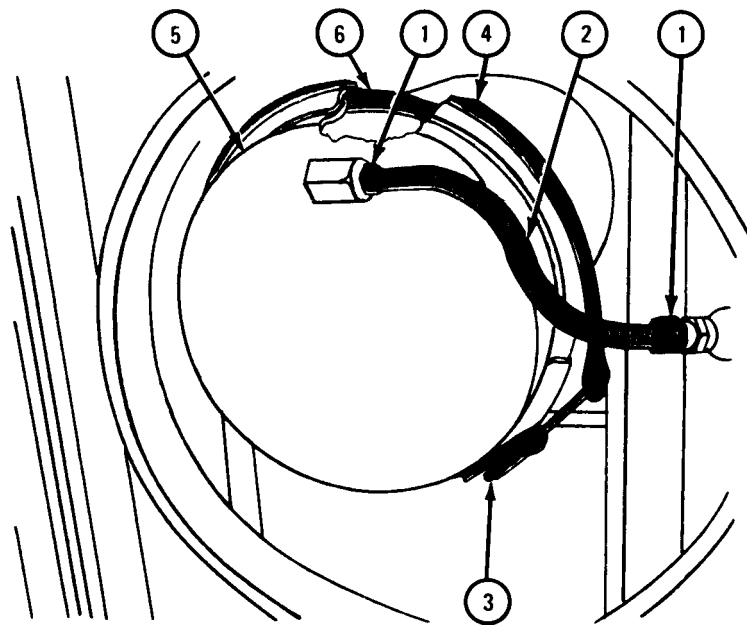

TA 046608



## FRAME 3

1. Using 7/16-inch wrench, unscrew and take off three nuts with flat washers (1) from studs (2).
2. Take plate (3) off mounting brackets (4).

GO TO FRAME 4

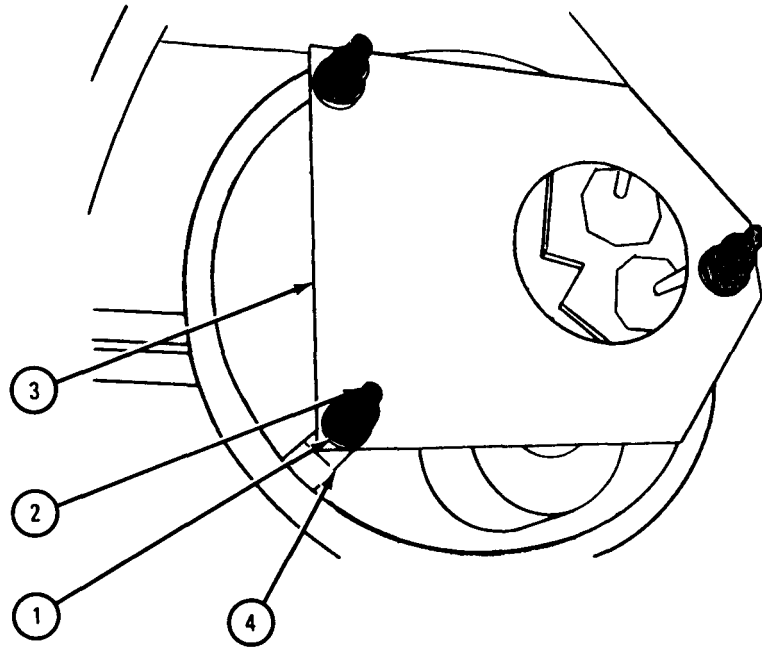

TA 046609

FRAME 4

CAUTION

Canisters are used again. Handle them carefully to prevent damage to Teflon coating on canister screen.

1. Lift three canisters (1) off filters (2).
2. Lift out three filters (2). Throw filters away.
3. Pull out three fuses (3). Throw fuses away.

END OF TASK

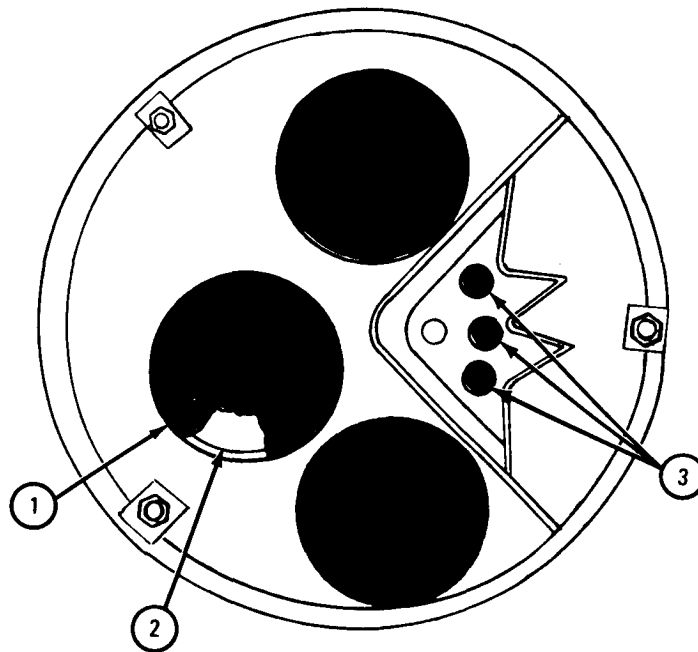

TA 046610

WARNING

Eye shields must be worn when using compressed air. Eye injury can occur if eye shields are not used.

CAUTION

Handle canisters carefully to prevent damage to Teflon coating on canister screen.

b. Cleaning. Using fuel, clean canisters and inside of housing. Dry with compressed air.

c. Replacement.

FRAME 1

CAUTION

Handle canisters (3) carefully to prevent damage to Teflon coating on canister screen.

1. Put three fuses (1) in place.
2. Put three filters (2) in place.
3. Put three canisters (3) on filters (2).

GO TO FRAME 2

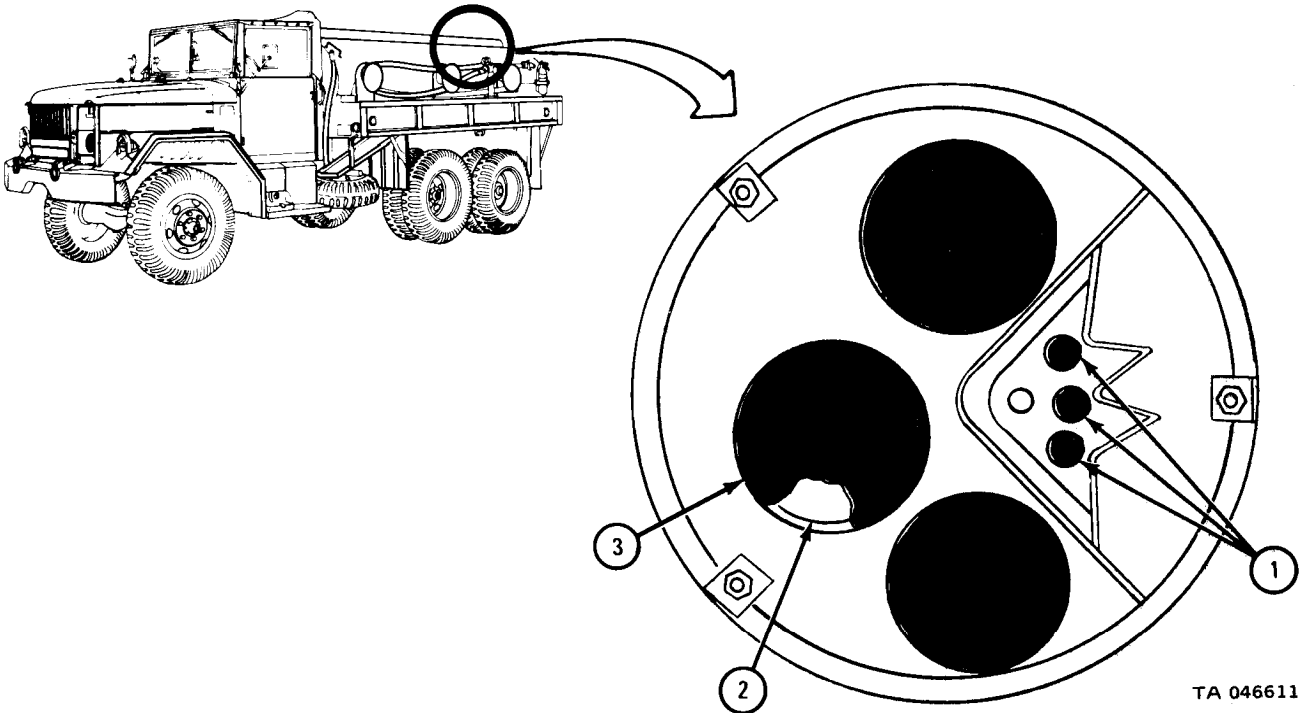

FRAME 2

1. Put plate (1) on brackets (2).
2. Using 7/16-inch wrench, screw on and tighten three nuts with flat washers (3) on studs (4).

GO TO FRAME 3

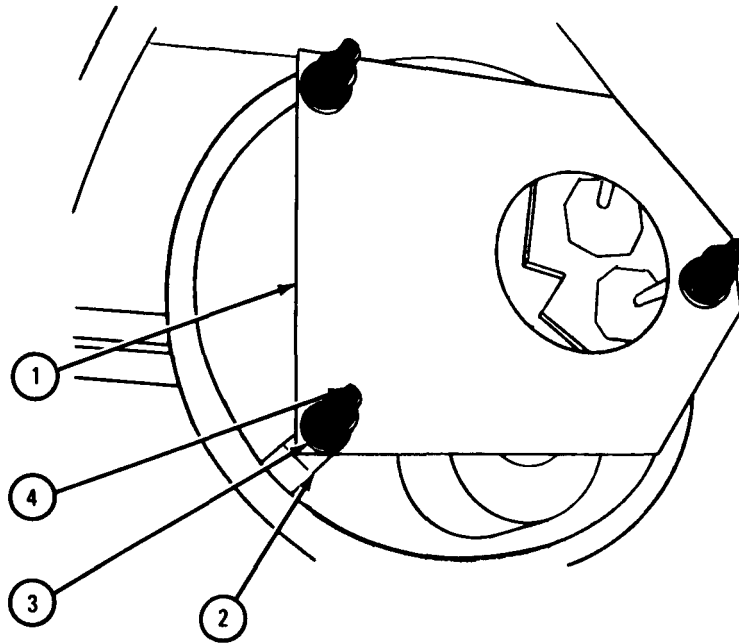

TA 046612

## FRAME 3

1. Put gasket (1) and cover (2) in place.
2. Put air vent line (3) in place. Turn cover (2) if needed to line up two coupling nuts (4) with two fittings (5). Hand tighten coupling nuts.
3. Put on and hand tighten clamp ring (6). Check that clamping holes cover (2). Using 1/2-inch wrench, tighten nut (7).
4. Using 13/16-inch wrench, tighten coupling nuts (4).

GO TO FRAME 4

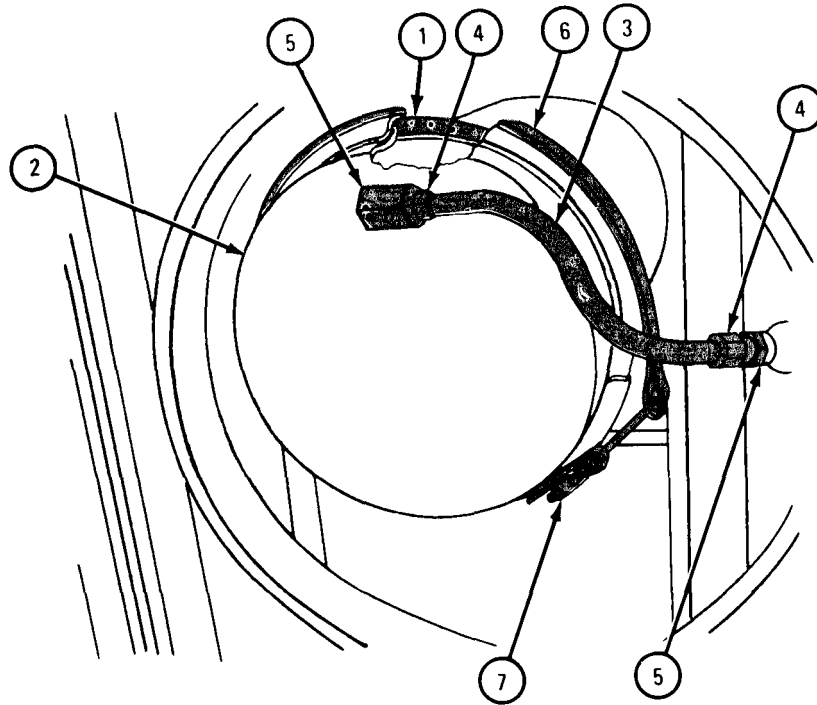

TA 046613

FRAME 4

1. Put gasket (1) and manhole cover (2) in place.
2. Put clamp ring (3) on so it holds manhole cover (2). Put bolt (4) in place in manhole cover. Using 9/16-inch wrenches, screw on and tighten bolt (4) and nut (5).

END OF TASK

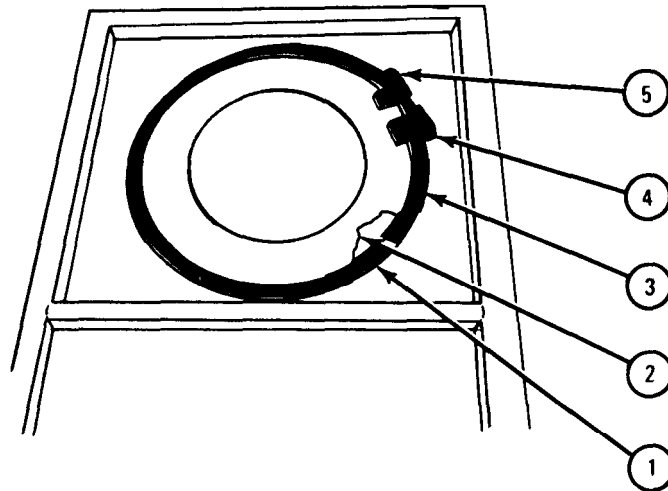

TA 046614

## 18-43. STATIC REEL ASSEMBLY REMOVAL AND REPLACEMENT (TRUCK M49A1C).

TOOLS: 9/16-inch open end wrench  
5/8-inch open end wrench

SUPPLIES: None

PERSONNEL: One

EQUIPMENT CONDITION: Truck parked, engine off, handbrake set.

WARNING

Smoking, sparks or open flame are not allowed within 50 feet of fuel truck during this task. Fuel may burn, causing explosion, injury to personnel, and damage to equipment.

a. Removal.

## FRAME 1

1. Open truck rear compartment doors.
2. Take two ground clamps (1) off frame (2).
3. Using 9/16-inch and 5/8-inch wrenches, unscrew and take out bolt (3) and nut (4) with lockwasher (5) and flat washer (6).
4. Take out static reel assembly (7).

END OF TASK

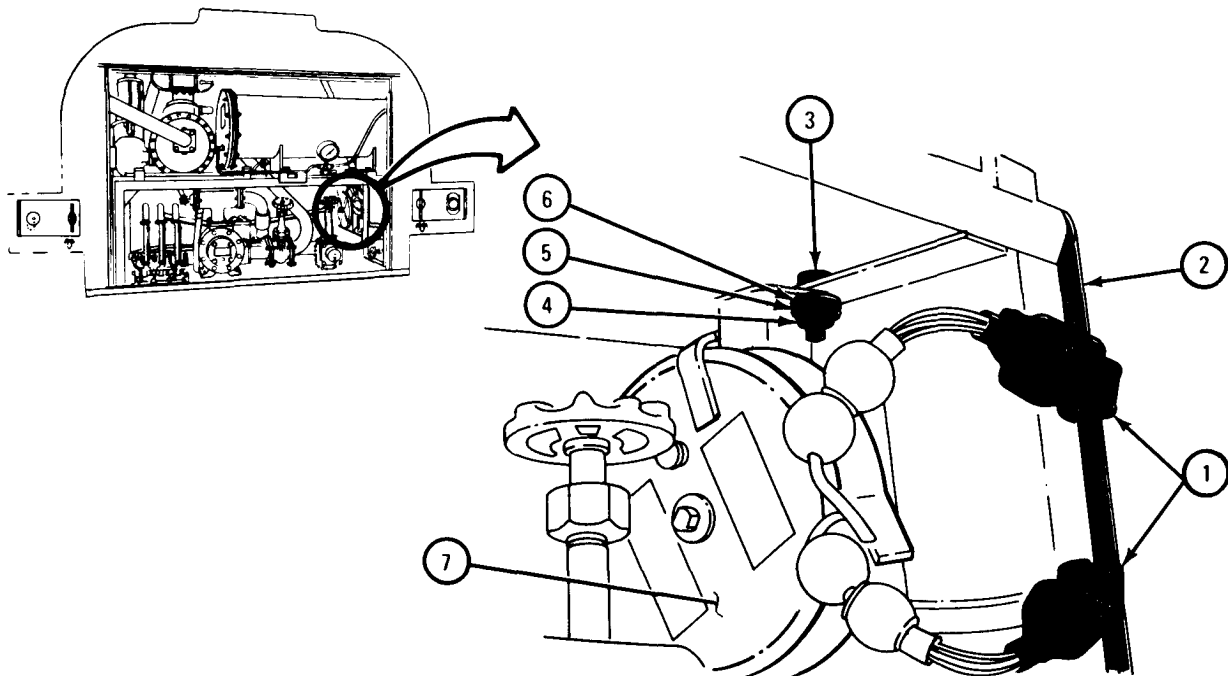

TA 046603

b. Replacement.

FRAME 1

1. Put static reel assembly (1) in place.
2. Using 9/16-inch and 5/8-inch wrenches, screw in and tighten bolt (2) and nut (3) with lockwasher (4) and flat washer (5).
3. Clip two ground clamps (6) onto frame (7).
4. Close truck rear compartment doors.

END OF TASK

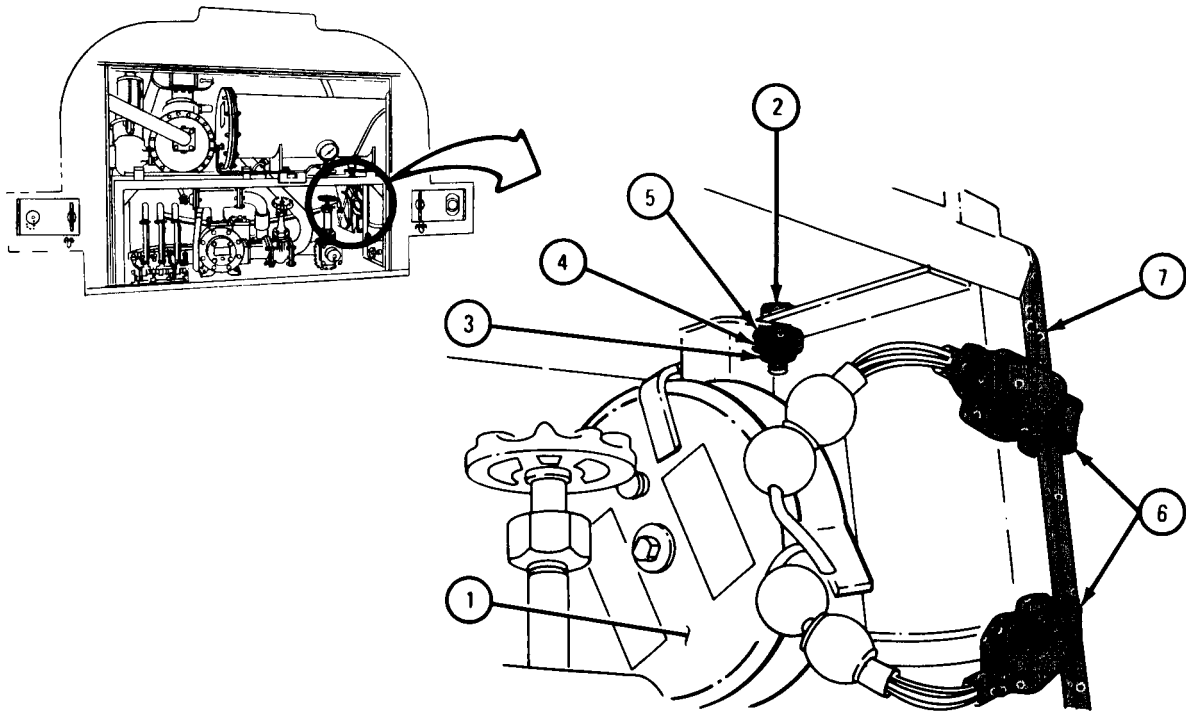

TA 046604



## 18-44. STATIC REEL ASSEMBLY REMOVAL AND REPLACEMENT (TRUCK M49A2C).

WARNING

Smoking, sparks or open flame are not allowed within 50 feet of fuel truck during this task. Fuel may burn, causing explosion, injury to personnel, and damage to equipment.

TOOLS: 9/16-inch wrench (2)

SUPPLIES: None

PERSONNEL: One

EQUIPMENT CONDITION: Truck parked, engine off, handbrake set.

a. Removal.

## FRAME 1

1. Using wrenches, unscrew and take off two screws (1) and nuts (2).
2. Take off static reel (3).

END OF TASK

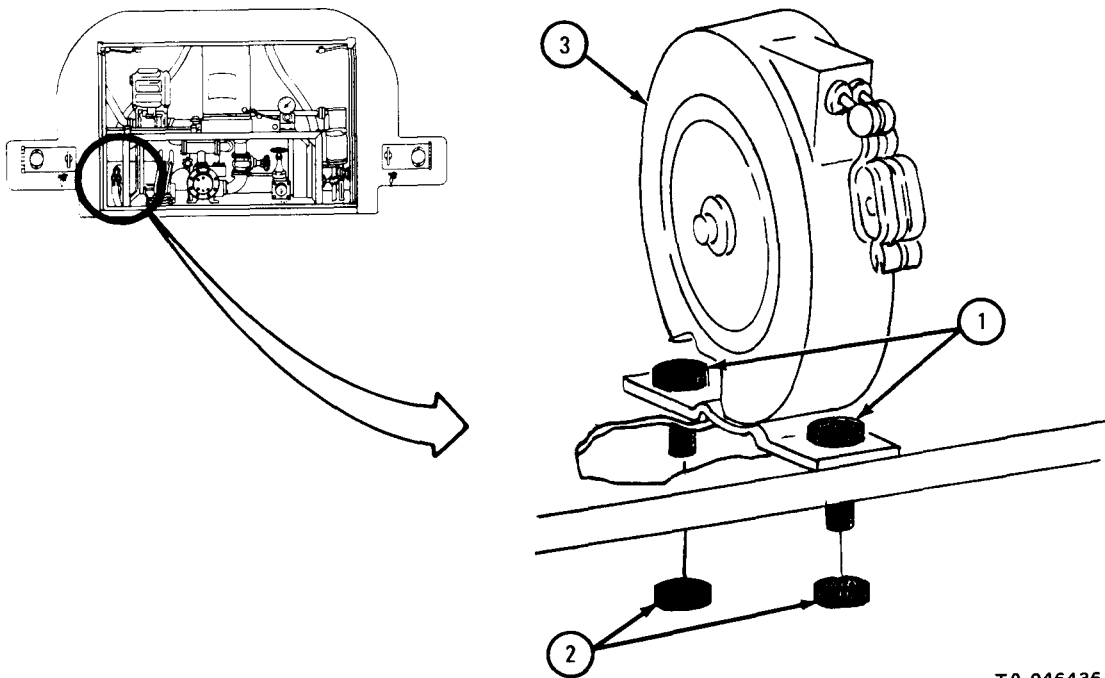

TA 046436

b. Replacement.

FRAME 1

1. Put static reel (1) onto shelf (2). Line up screw holes.
2. Put two screws (3) through static reel (1) and shelf (2). Using wrenches, screw on and tighten two screws (3) and nuts (4).

END OF TASK

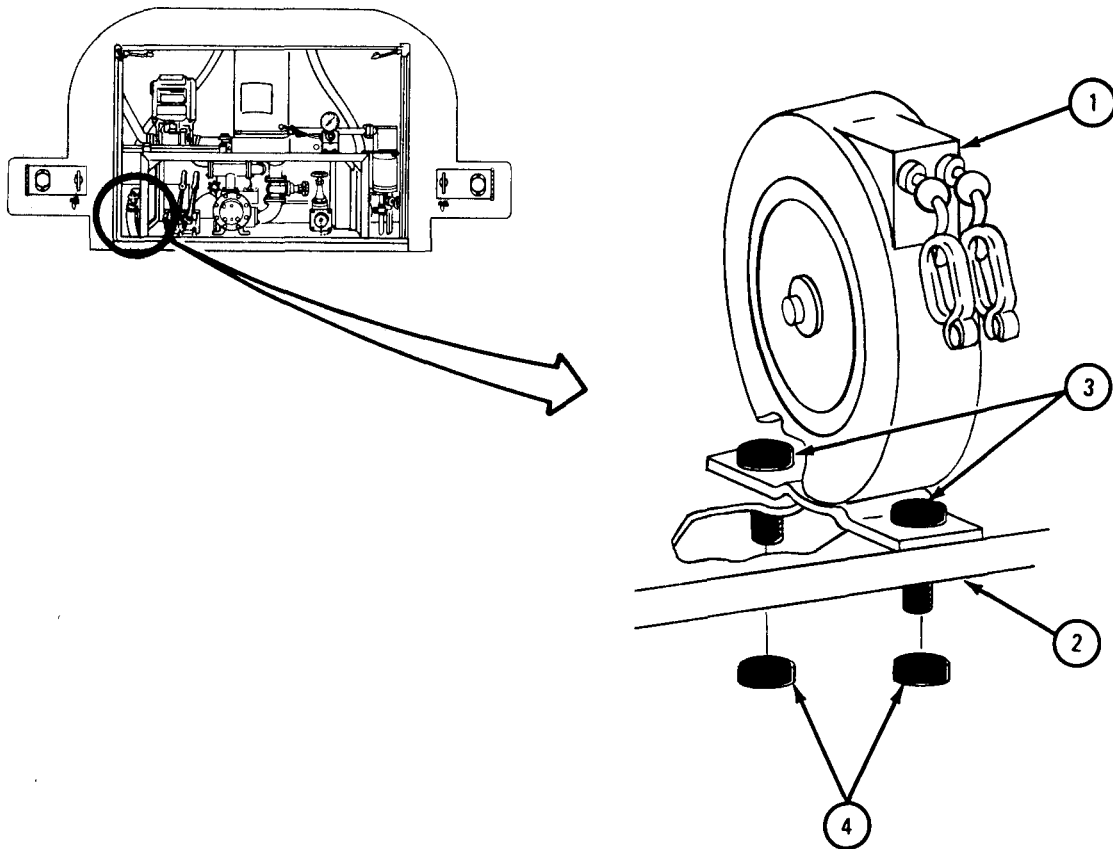

TA 046437

## 18-45. STATIC REEL ASSEMBLY REPAIR (TRUCKS M49A1C AND M49A2C).

WARNING

Smoking, sparks or open flame are not allowed within 50 feet of fuel truck during this task. Fuel may burn, causing explosion, injury to personnel, and damage to equipment.

TOOLS: Flat-tip screwdriver  
7/16-inch socket wrench

SUPPLIES: None

PERSONNEL: One

EQUIPMENT CONDITION: Truck parked, engine off, handbrake set.

a. Disassembly.

## FRAME 1

1. Open truck rear compartment doors.
2. Using screwdriver and wrench, unscrew and take off nut with lockwasher (1) and screw with flat washers (2).
3. Take cable (3) off clamp (4).
4. Do steps 1, 2, and 3 again for other clamp on other cable.

END OF TASK

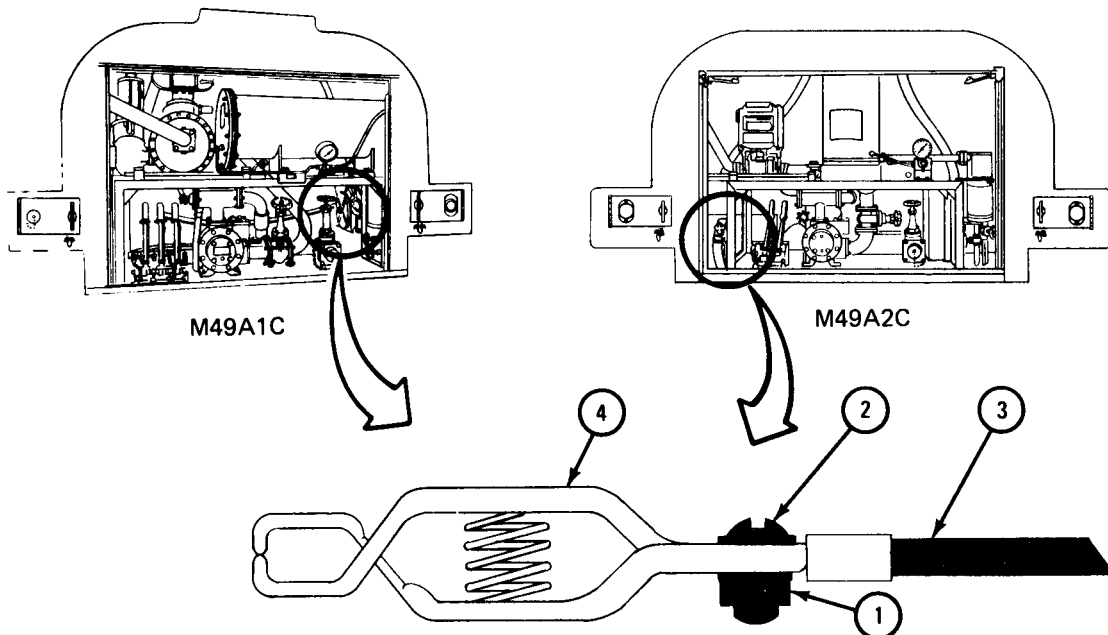

TA 046605

b. Assembly.

FRAME 1

1. Put screw with flat washer (1) through loop in cable (2) and in hole in clamp (3).
2. Using screwdriver and wrench, screw on and tighten nut with lockwasher (4).
3. Do steps 1 and 2 again for other clamp and cable.
4. Close truck rear compartment door.

END OF TASK

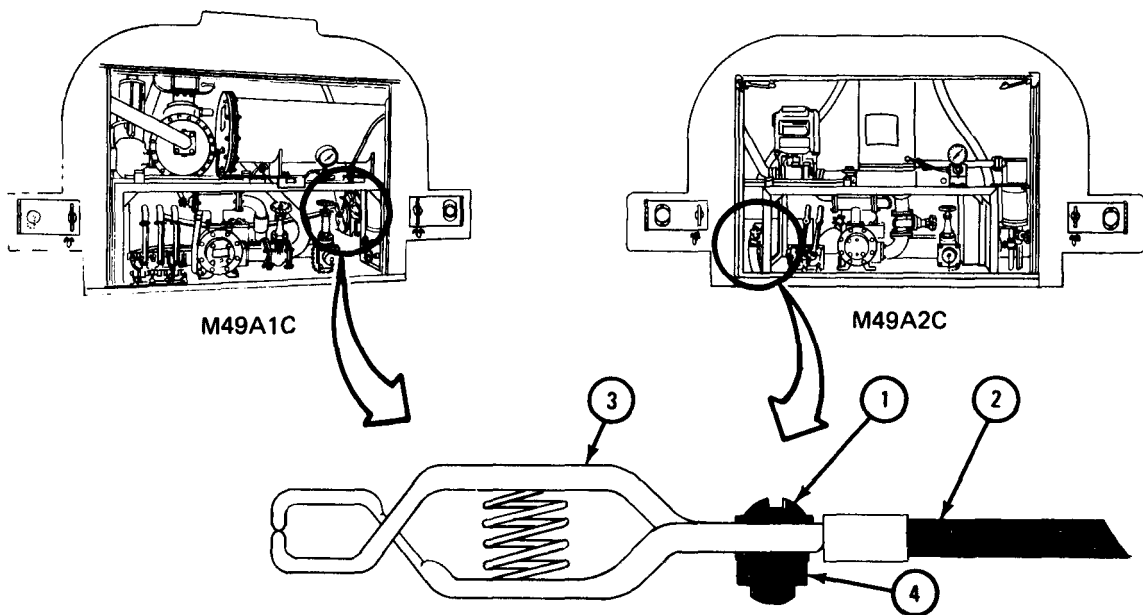

TA 046606

18-46. GALLON INDICATING METER REMOVAL AND REPLACEMENT (TRUCK M49A1C).

WARNING

Smoking, sparks or open flame are not allowed within 50 feet of fuel truck during this task. Fuel may burn, causing explosion, injury to personnel, and damage to equipment.

TOOLS: Pipe wrench  
Open end wrench set, pn GGG-W-636  
Authorized fuel container  
Scraper

SUPPLIES: Inlet gasket  
Outlet gasket  
Liquid gasket sealer, type II, MIL-S-45180  
Cloth backed adhesive tape, MIL-T-43566A

PERSONNEL: One

EQUIPMENT CONDITION: Truck parked, engine off, handbrake set.

- a. Preliminary Procedure. Open fuel truck rear compartment doors.
- b. Removal.

FRAME 1

1. Open fuel container and put it under fuel drain line (1). Turn handle on globe valve (2) to the left. When fuel stops draining, close valve by turning to the right.
2. Take container away.
3. Using pipe wrench, unscrew pipe (3) from meter (4).

GO TO FRAME 2

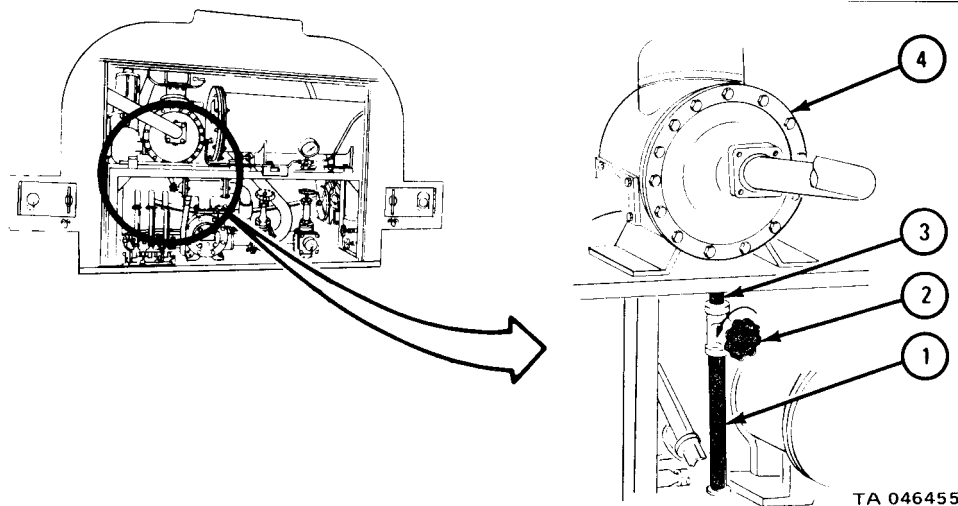

FRAME 2

1. Using wrench, unscrew coupling nut (1). Pull air eliminator tube (2) out and carefully put it aside. Using wrench, unscrew and take out elbow (3).
2. Using wrench, unscrew and take out four screws with lockwashers (4). Take off gasket (5).

GO TO FRAME 3

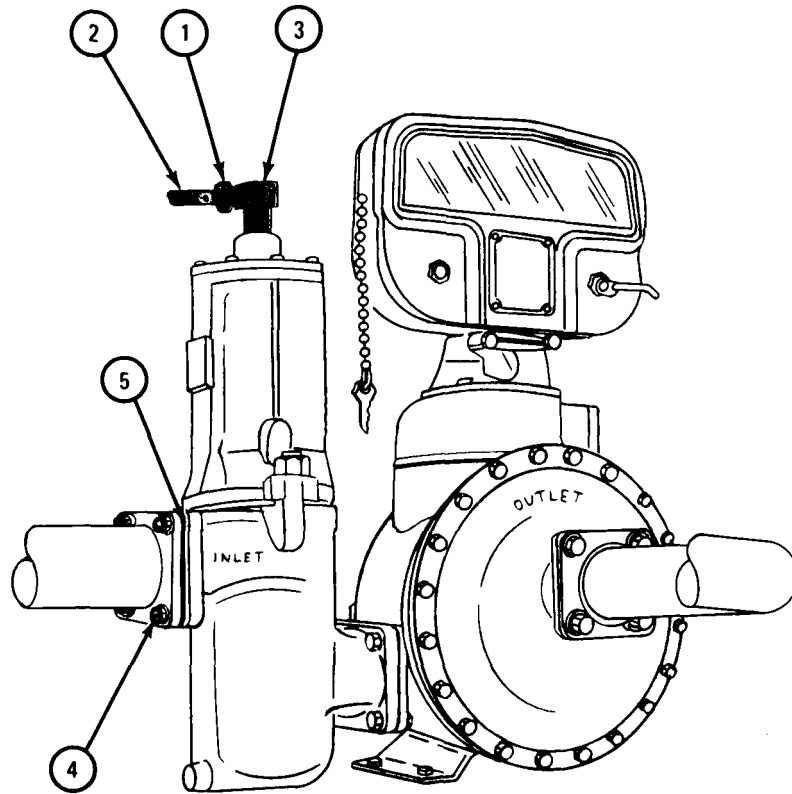

TA 046456

## FRAME 3

1. Using wrench, unscrew and take out four screws with lockwashers (1). Take out gasket (2).
2. Move pipe (3) away. Cover opening in meter (4) with tape.

GO TO FRAME 4

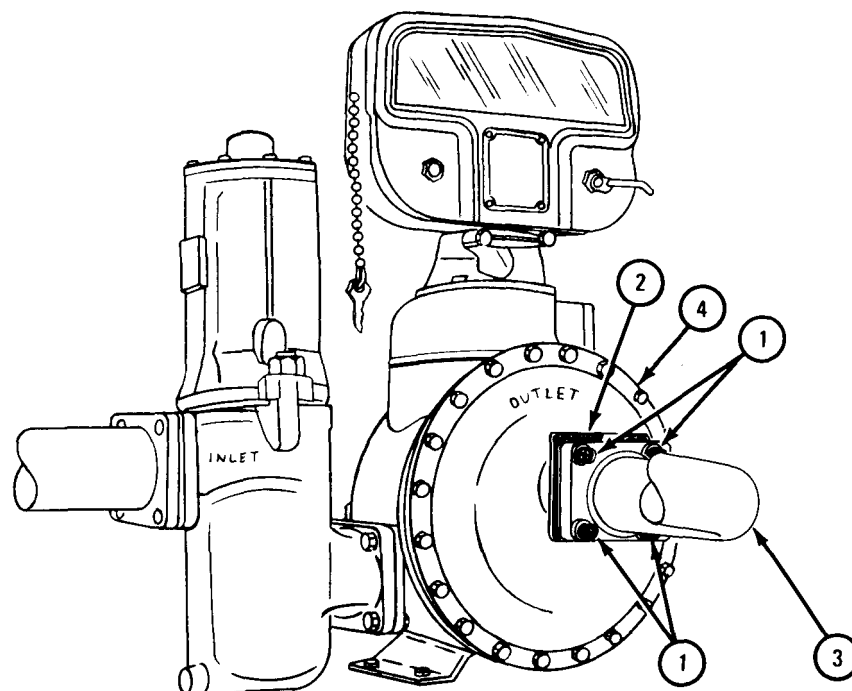

TA 046457

FRAME 4

1. Using wrenches, unscrew and take off four nuts with lockwashers (1). Take out four screws (2).
2. Carefully work meter (3) up and out of rear compartment.

END OF TASK

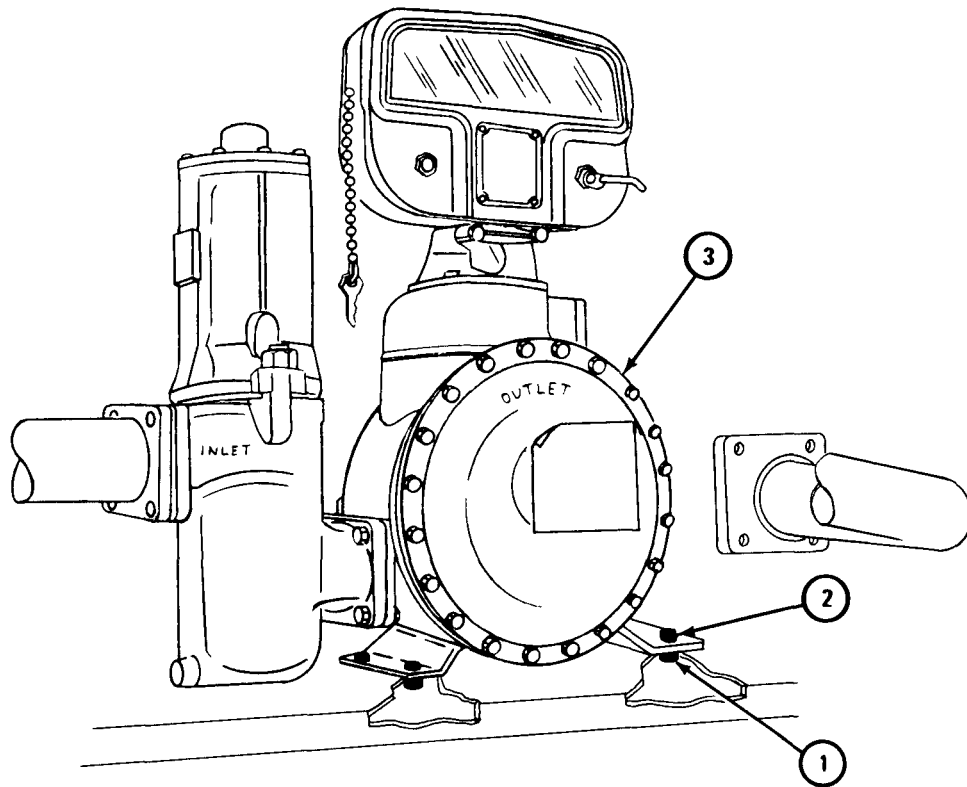

TA 046458



c. Replacement.

## FRAME 1

1. Check flanges of pipes (1 and 2) and clean the gasket area. Use scraper, if needed.
2. Using rag, wipe out dirt from inside of pipes (1 and 2) near flanges.

GO TO FRAME 2

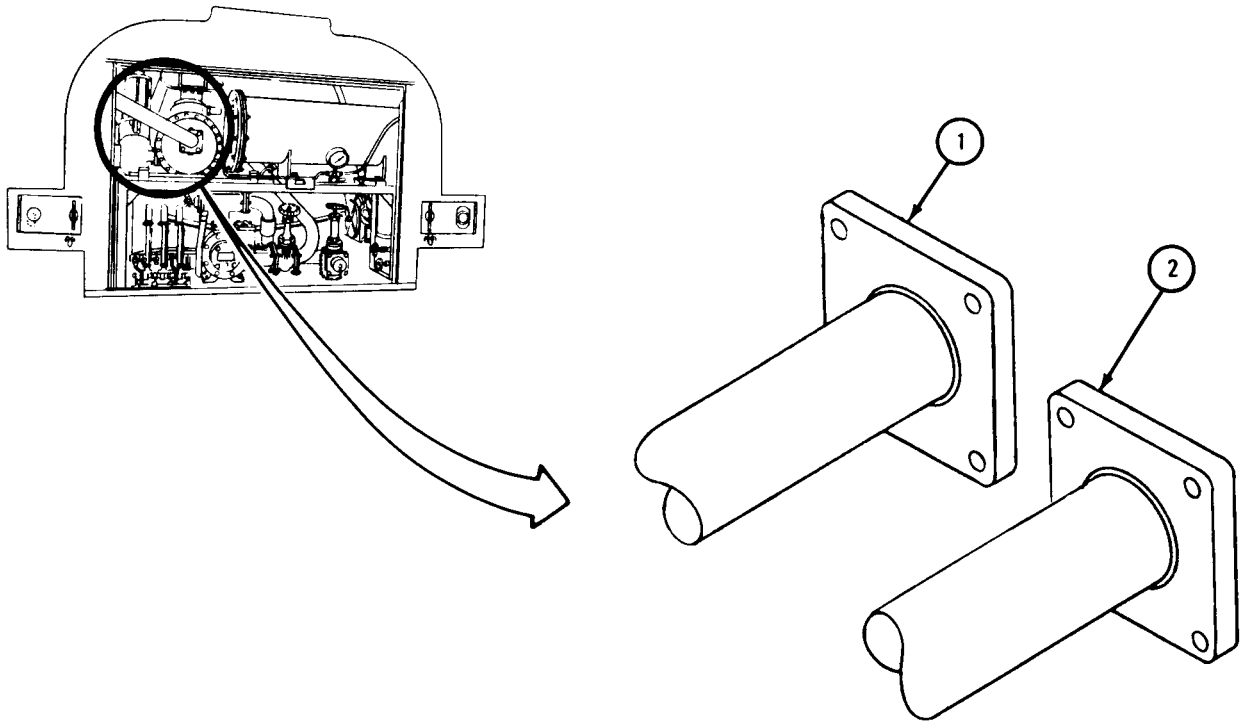

TA 046461

FRAME 2

NOTE

If meter has plugs in pipe connections, take them out before putting meter on shelf.

1. Carefully work meter (1) on shelf (2) and dine screw holes.
2. Put four screws (3) through holes in meter (1) and shelf (2) and hold with wrench. Using wrench, screw on and tighten four nuts with lockwashers (4).
3. Take tape (5) off opening in meter (1).

GO TO FRAME 3

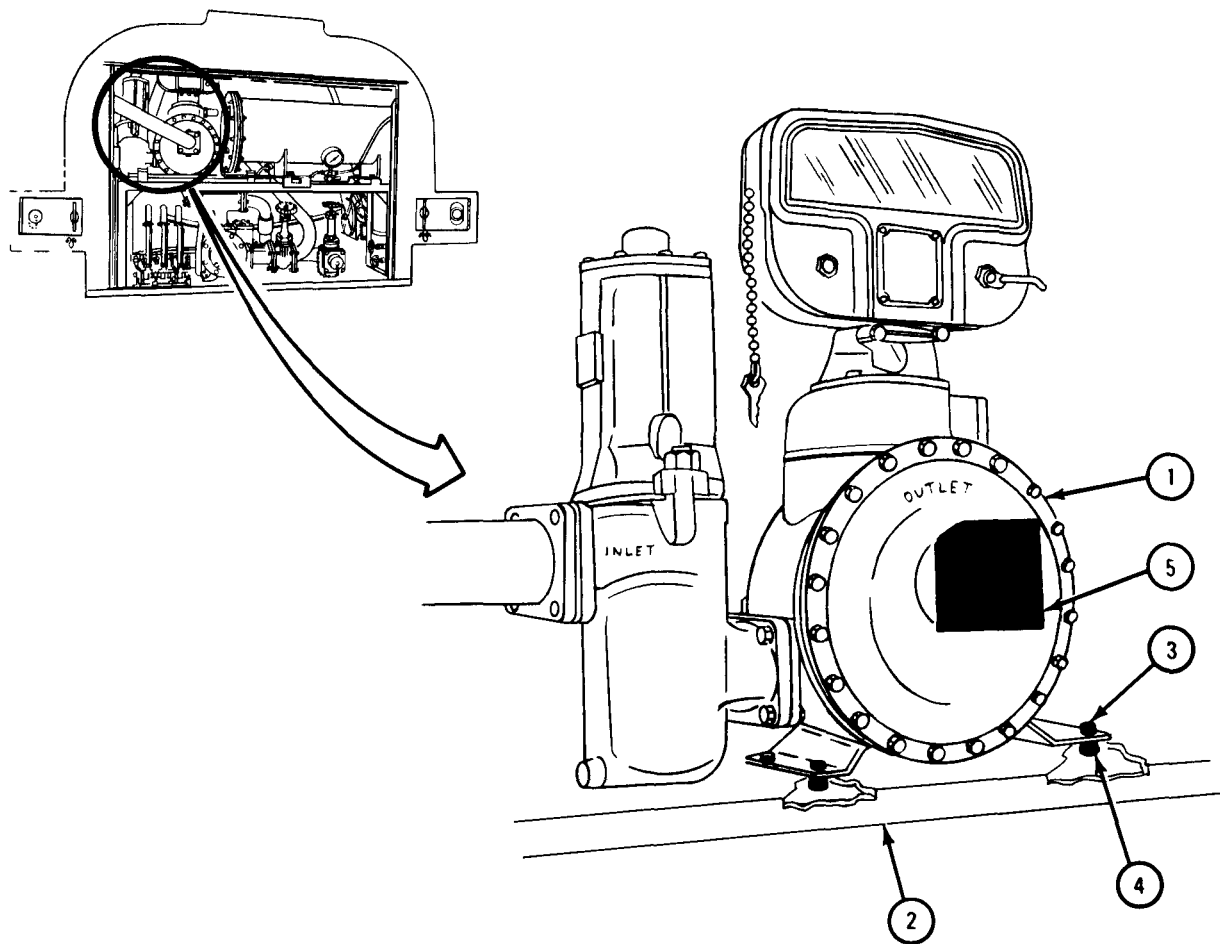

TA 046462

## FRAME 3

1. Coat both sides of gasket (1) with liquid gasket sealer. Put gasket between pipe (2) flange and meter flange (3) and align screw holes.
2. Using wrench, screw in and tighten four screws with lockwashers (4).
3. Using wrench, screw in elbow (5).

GO TO FRAME 4

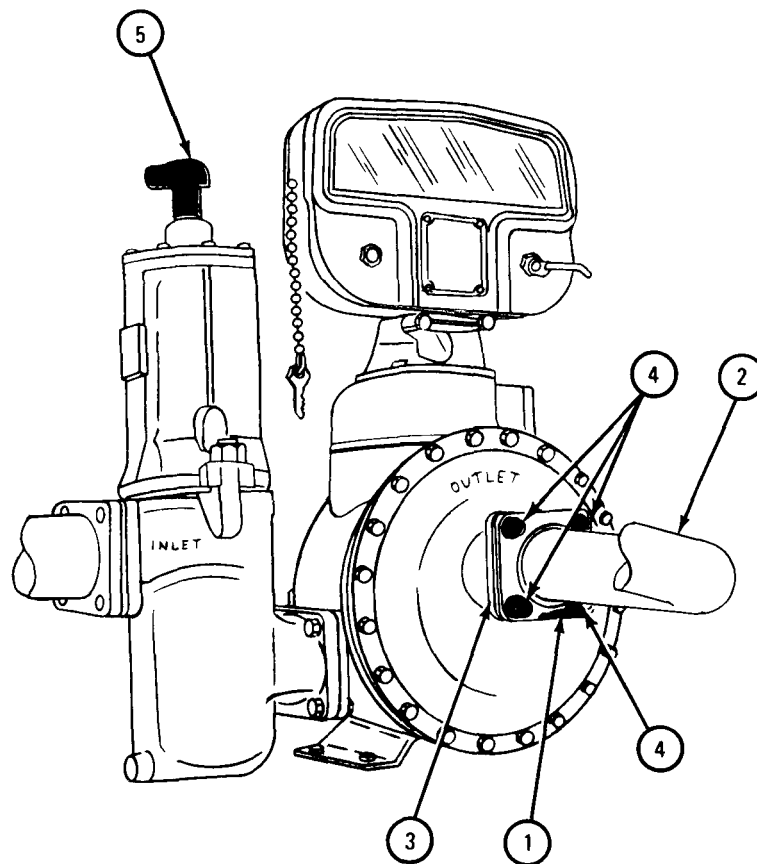

TA 046463

**FRAME 4**

1. Put air eliminator tube (1) into elbow (2). Using wrench, screw on and tighten coupling nut (3).
2. Coat both sides of gasket (4) with liquid gasket sealer. Put gasket between pipe flange (5) and meter flange (6) and align screw holes.
3. Using wrench, screw in and tighten four screws with lockwashers (7).

GO TO FRAME 5

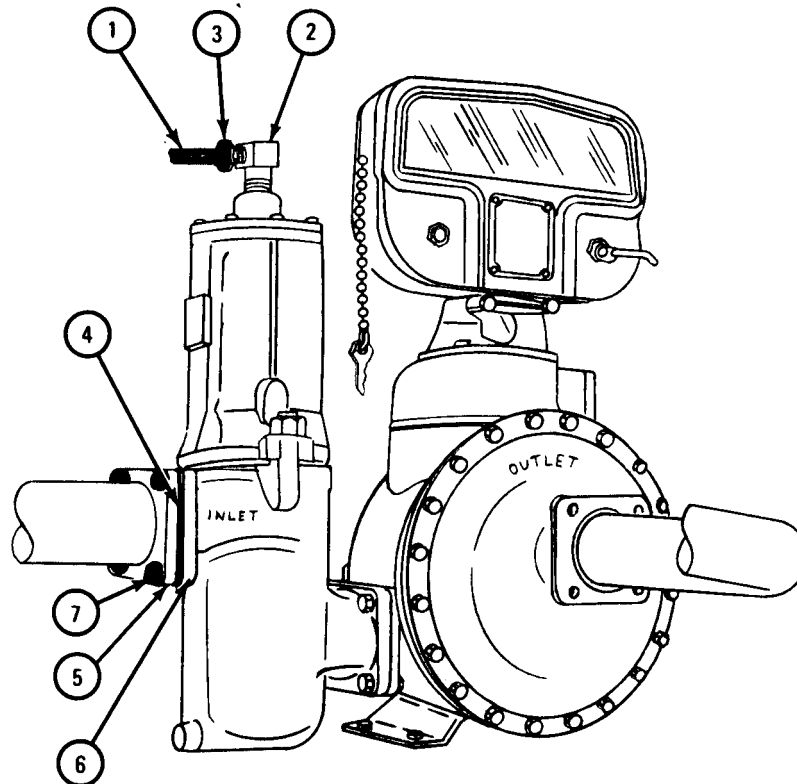

TA 046465

## FRAME 5

1. Using pipe wrench, screw pipe (1) into meter (2).
2. Check that globe valve handle (3) is turned all the way to the right.

## NOTE

Follow-on Maintenance Action Required:  
Close fuel truck rear compartment doors.

END OF TASK

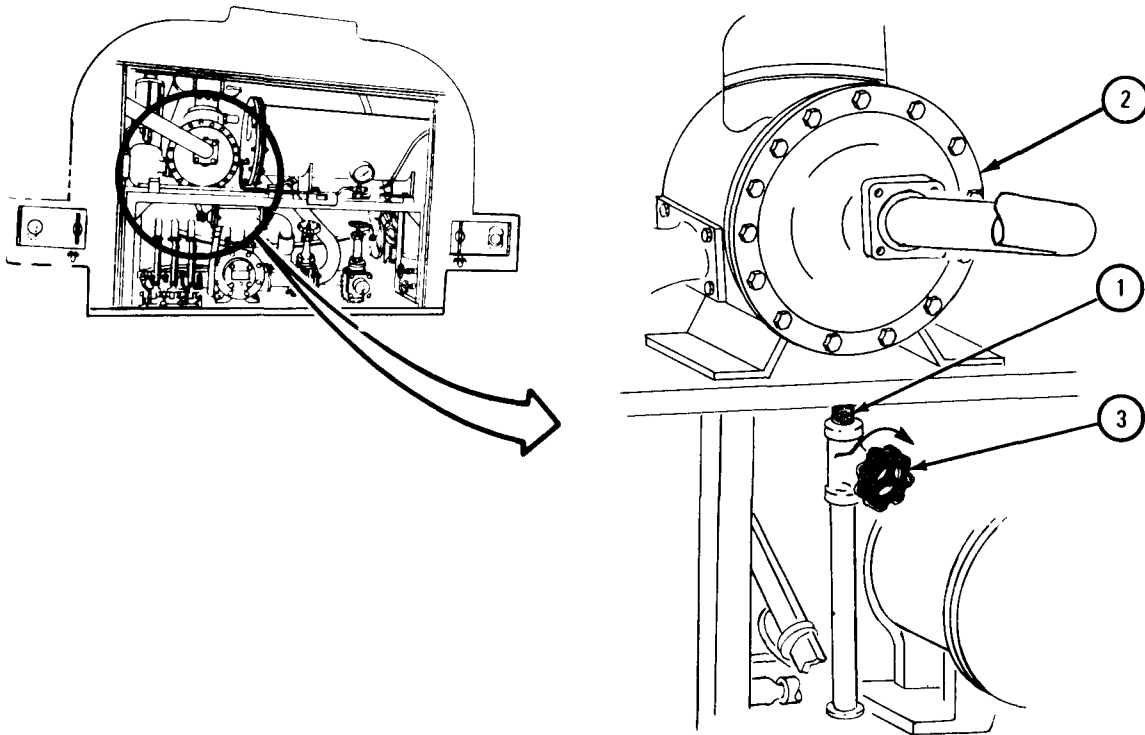

TA 046460

18-47. GALLON INDICATING METER REMOVAL AND REPLACEMENT  
(TRUCK M49A2C) .

TOOLS: 9/16-inch wrench  
13/16-inch wrench  
15/16-inch wrench (2)  
18-inch pipe wrench  
7/8-inch wrench  
Wide pan

SUPPLIES: Gasket (2)  
Liquid gasket sealer, type II, MIL-S-45180

PERSONNEL: One

EQUIPMENT CONDITION: Truck parked, engine off, handbrake set.

WARNING

To prevent fire or explosion, smoking, flame, sparks, and glowing or hot objects are not allowed within 50 feet of work area during this task.

a. Removal.

**FRAME 1**

1. Open fuel truck rear compartment doors.
2. Put wide pan below truck under drain pipe (1) . Turn globe valve handle (2) slowly to the left until fuel slowly drains from drain line.
3. When drain line (1) is empty, turn globe valve handle (2) all the way to the right. Take out wide pan and put fuel in approved disposal area.

GO TO FRAME 2

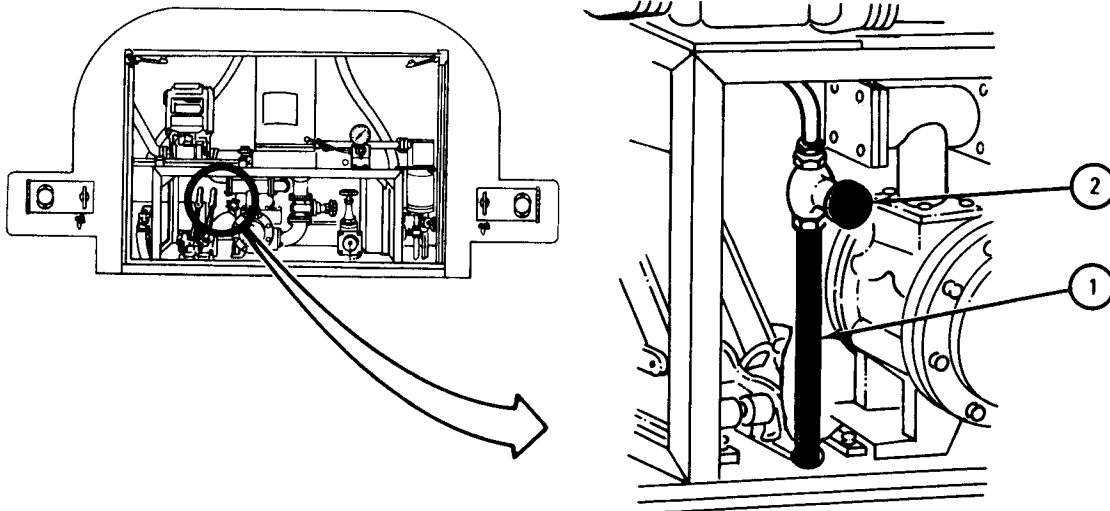

TA 046468

## FRAME 2

1. Using 15/16-inch wrench, hold two nuts (1). Using 15/16-inch wrench, unscrew and take out two bolts (2). Take off nuts.
2. Take out gasket (3) and throw it away.
3. Do steps 1 and 2 again for gasket (4) on other side of meter (5).

GO TO FRAME 3

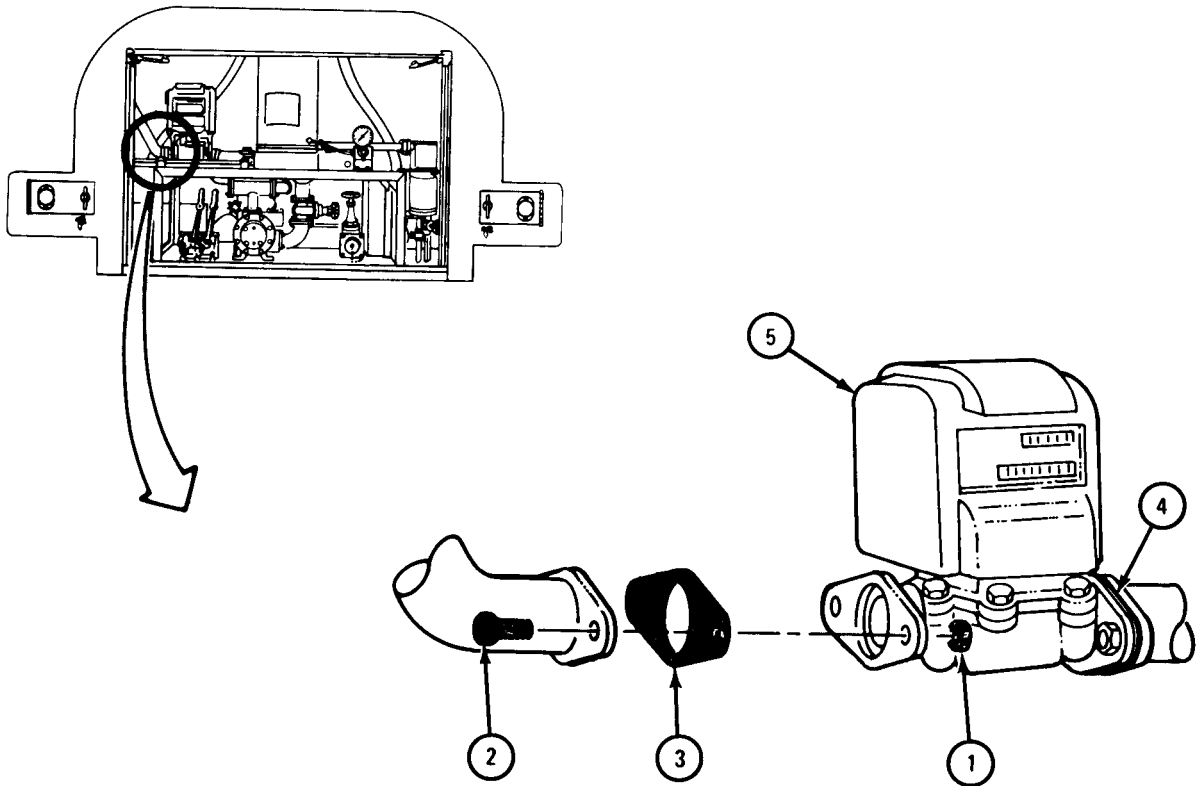

TA 046469

FRAME 3

1. Using 9/16-inch wrench, unscrew and take out three bolts (1) with lockwashers (2).
2. Using 7/8-inch wrench and pipe wrench, unscrew valve (3) from pipe (4).
3. Take off meter (5). Pipe (4) will come off with meter.

GO TO FRAME 4

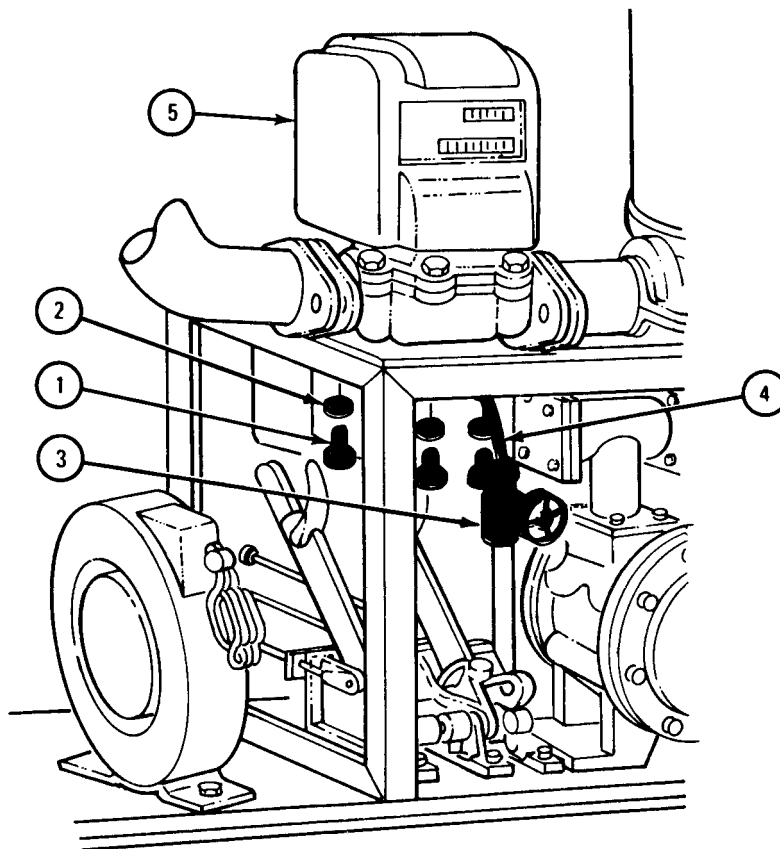

TA 046470



## FRAME 4

## NOTE

Before unscrewing pipe, note its position so it can be screwed into meter in the same position.

1. Using pipe wrench, unscrew and take off pipe (1).
2. Using 13/16-inch wrench, unscrew and take off elbow (2).

END OF TASK

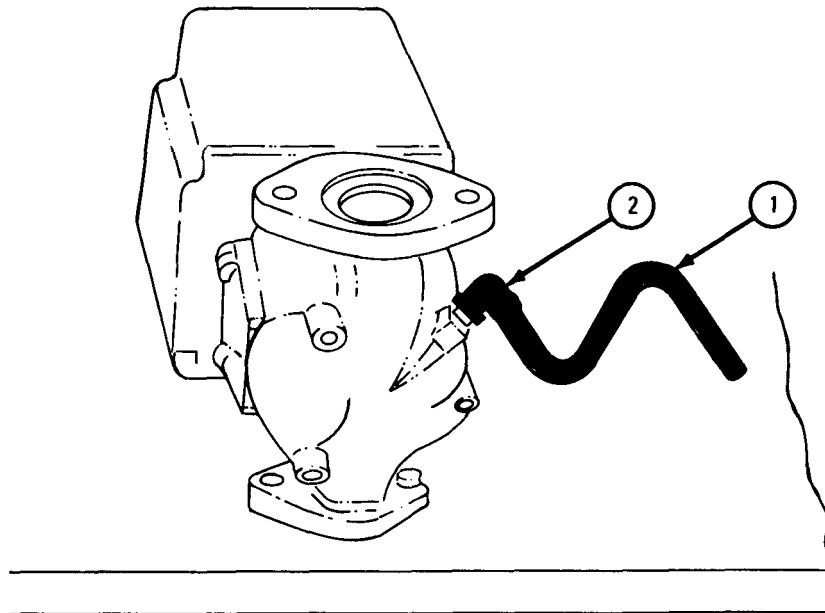

TA 046471

b. Replacement.

FRAME 1

1. Using 13/16-inch wrench, screw on and tighten elbow (1).
  2. Using pipe wrench, screw on pipe (2) to elbow (1) in position noted.
- GO TO FRAME 2

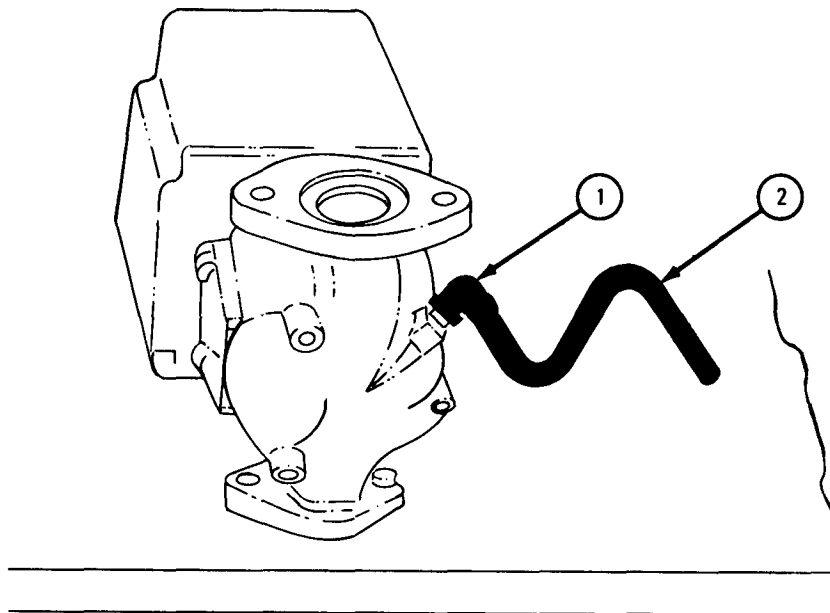

TA 046472

## FRAME 2

1. Put meter (1) on shelf (2), alining three mounting holes for bolts (3) with lockwashers (4).
2. Using 9/16-inch wrench, screw in and tighten three bolts (3) with lockwashers (4).
3. Using 7/8-inch wrench and pipe wrench, screw on and tighten valve (5) onto pipe (6).

GO TO FRAME 3

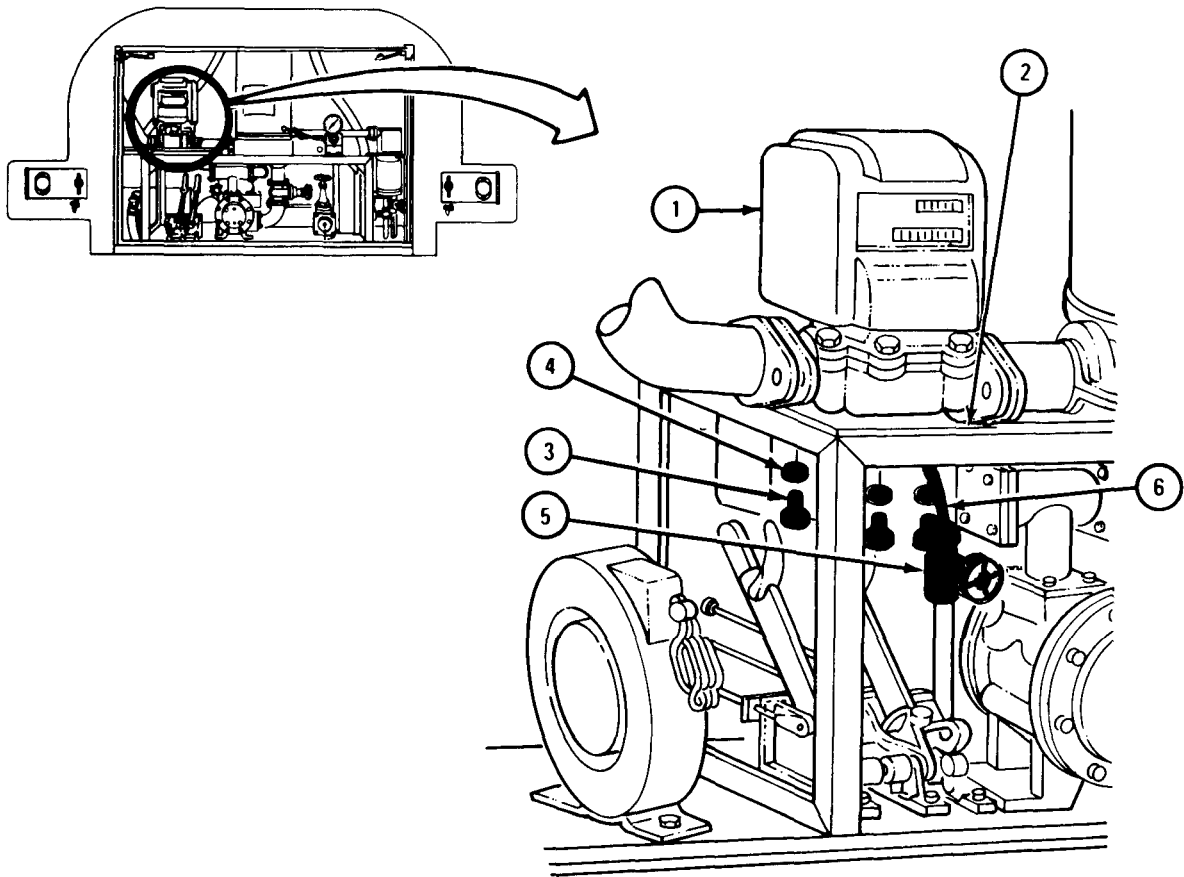

TA 046473

FRAME 3

1. Put gasket (1) between pipe flange (2) and meter flange (3), alining holes. Put two bolts (4) through pipe flange, gasket, and meter flange.
2. Using 15/16-inch wrench, hold nuts (5). Using 15/16-inch wrench, screw in and tighten bolts (4).
3. Do steps 1 and 2 again for gasket (6) on other side of meter.
4. Close fuel truck rear compartment door.

END OF TASK

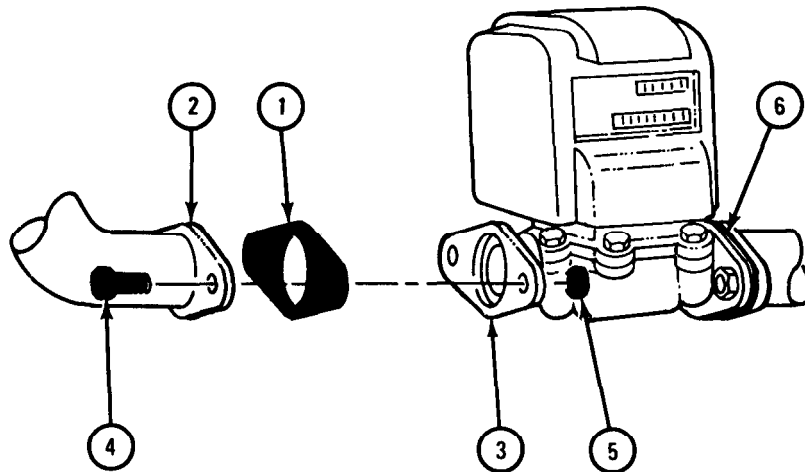

TA 046474

## 18-48. HOSE AND NOZZLE ASSEMBLY REMOVAL AND REPLACEMENT.

WARNING

Smoking, sparks, or open flame are not allowed within 50 feet of work area during this task. Use only nonsparking tools. Fuel may burn and cause an explosion.

TOOLS: Adjustable wrench  
Spanner wrench

SUPPLIES: Gasket (2)

PERSONNEL: One

EQUIPMENT CONDITION: Truck parked, engine off, handbrake set.

a. Removal.

FRAME 1

## NOTE

Some hoses may have spring (1) on end. The procedure is the same for both hoses.

1. Using spanner wrench, hold fitting (2). Using adjustable wrench, unscrew coupling nut (3).
2. Take off hose (4) from fitting (2).

GO TO FRAME 2

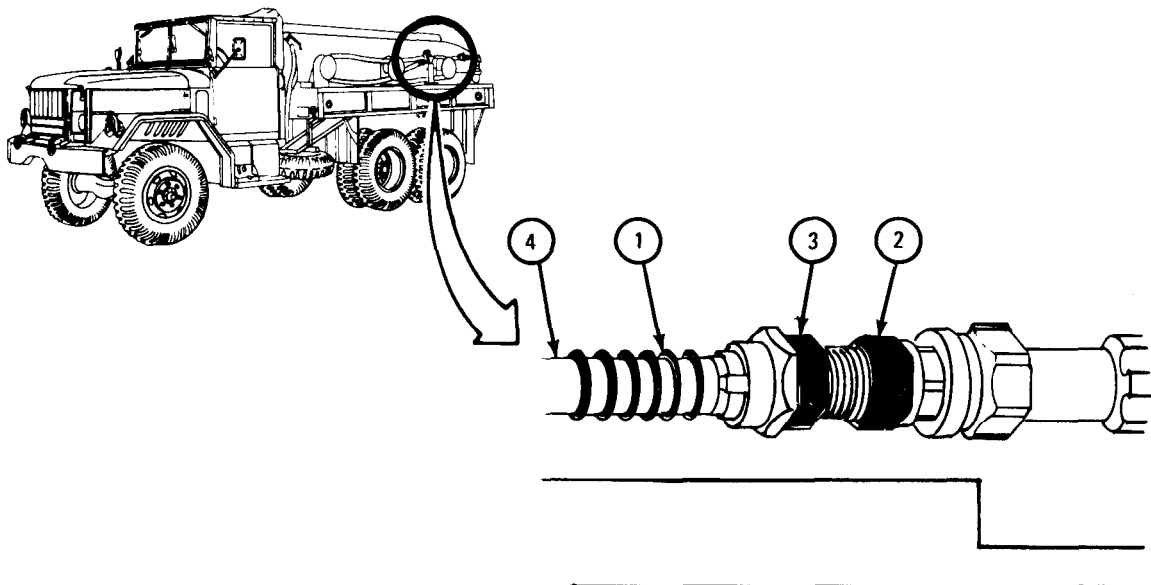

TA 046595

FRAME 2

1. Take gasket (1) out of coupling nut (2).
2. Throw gasket away. Move hose (3) out of the way.

GO TO FRAME 3

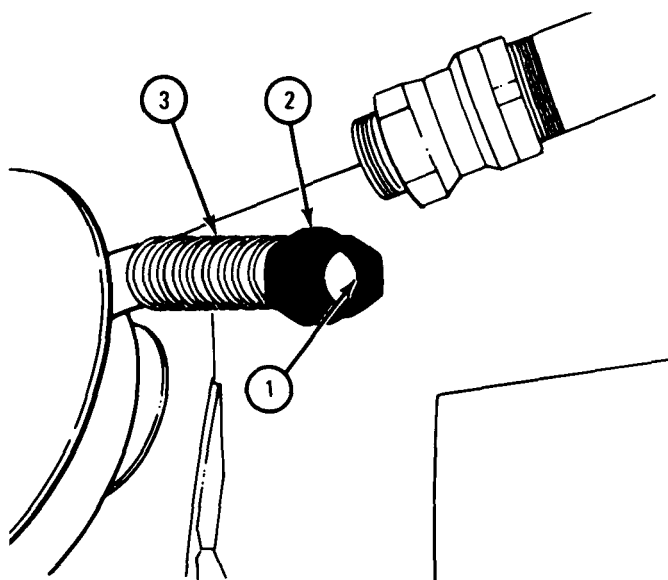

TA 046599

## FRAME 3

1. Using adjustable wrench, hold fitting (1). Unscrew and take off nozzle assembly (2).
2. Take gasket (3) out of fitting (1). Throw away gasket.

END OF TASK

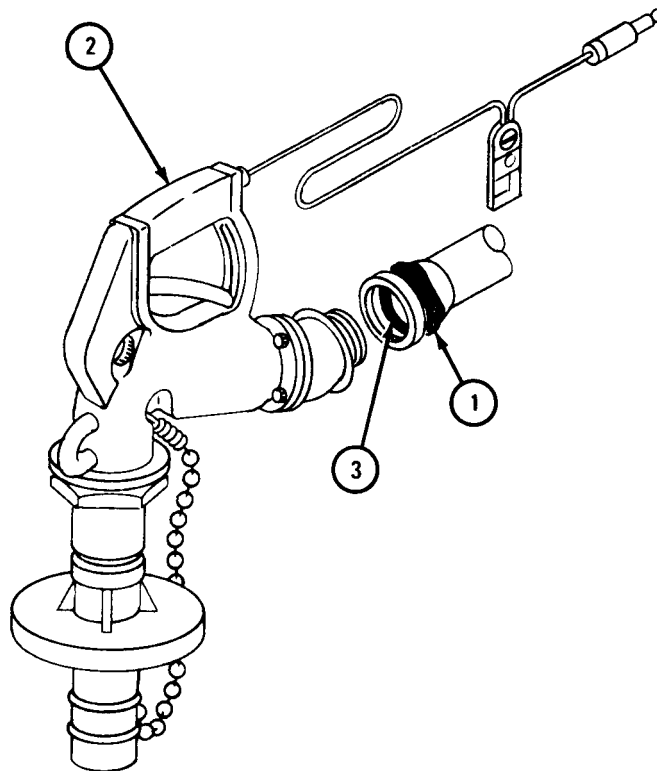

TA 101560

b. Replacement.

FRAME 1

1. Put gasket (1) into fitting (2) and seat gasket.
2. Using adjustable wrench, hold fitting (1). Screw on and tighten nozzle assembly (3) to fitting.

GO TO FRAME 2

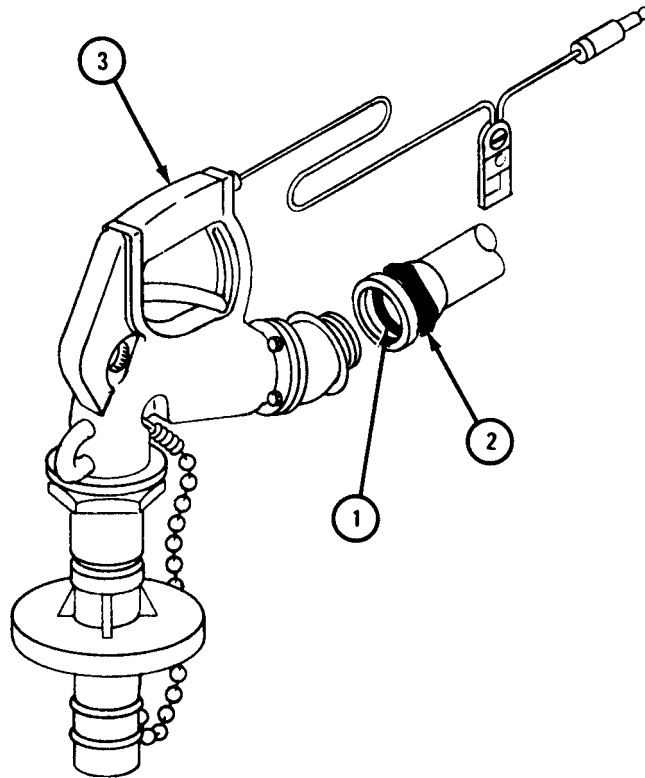

TA 101561



FRAME 2

1. Put hose (1) in place. Put gasket (2) into coupling nut (3) and seat gasket.
- GO TO FRAME 3

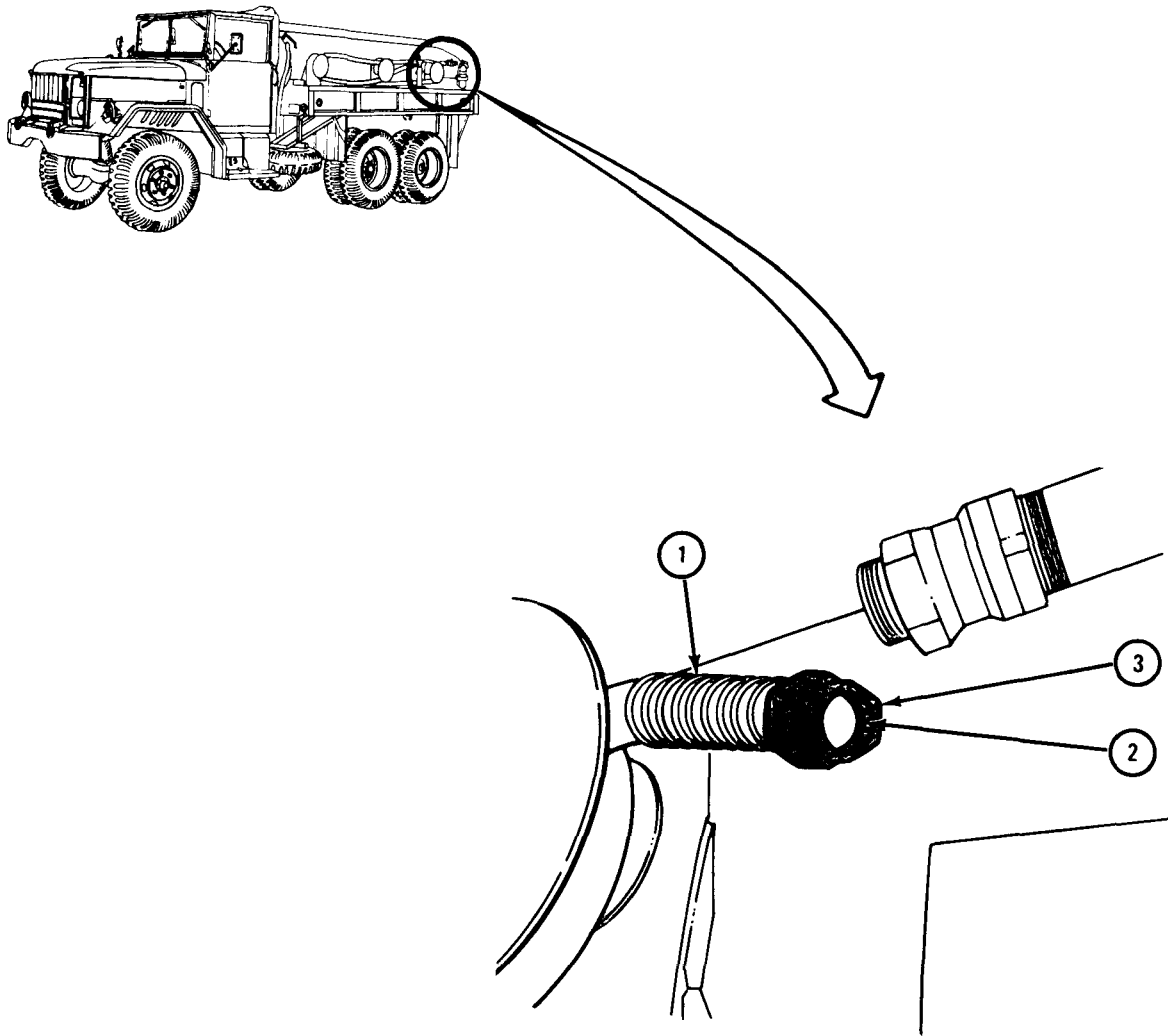

TA 046602

FRAME 3

1. Screw on coupling nut (1) to fitting (2). Using spanner wrench, hold fitting. Using adjustable wrench, tighten coupling nut.

NOTE

Follow-on Maintenance Action Required:

Stow hose in traveling position. Refer to TM 9-2320-209-10.

END OF TASK

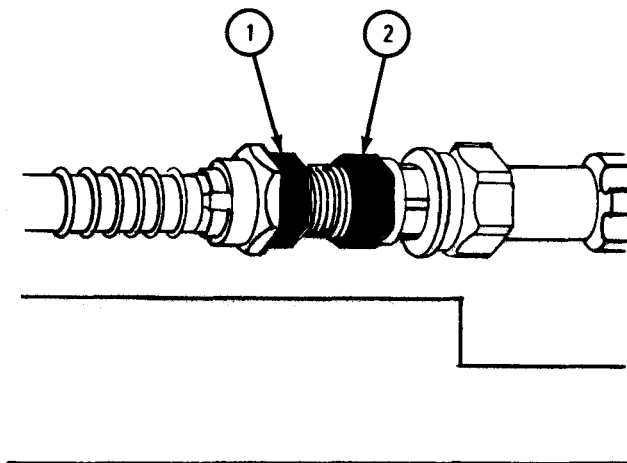

TA 046598

## 18-49. HOSE COUPLING GASKET REMOVAL AND REPLACEMENT (TRUCK M49A1C).

WARNING

Smoking, sparks, or open flame are not allowed within 50 feet of work area during this task. Fuel may burn, causing explosion, injury to personnel, and damage to equipment.

TOOLS: 2 11/16-inch open end wrench  
2 1/4-inch open end wrench

SUPPLIES: Hose coupling gasket

PERSONNEL: One

EQUIPMENT CONDITION: Truck parked, engine off, handbrake set.

a. Removal.

## FRAME 1

1. Using 2 11/16-inch wrench, hold nut (1). Using 2 1/4-inch wrench, unscrew coupling nut (2) from pipe (3).
2. Take hose (4) away from pipe (3).

GO TO FRAME 2

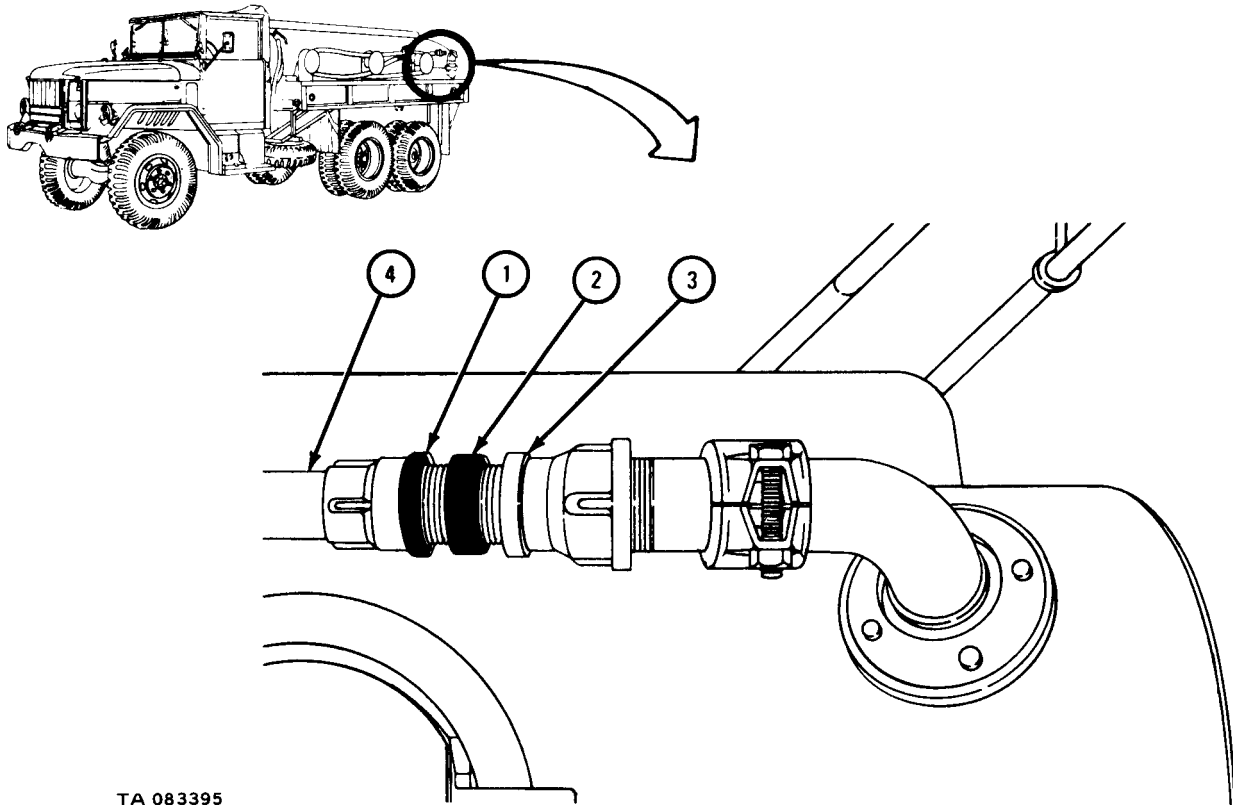

TA 083395

FRAME 2

1. Take gasket (1) out of coupling nut (2). Throw gasket away.

END OF TASK

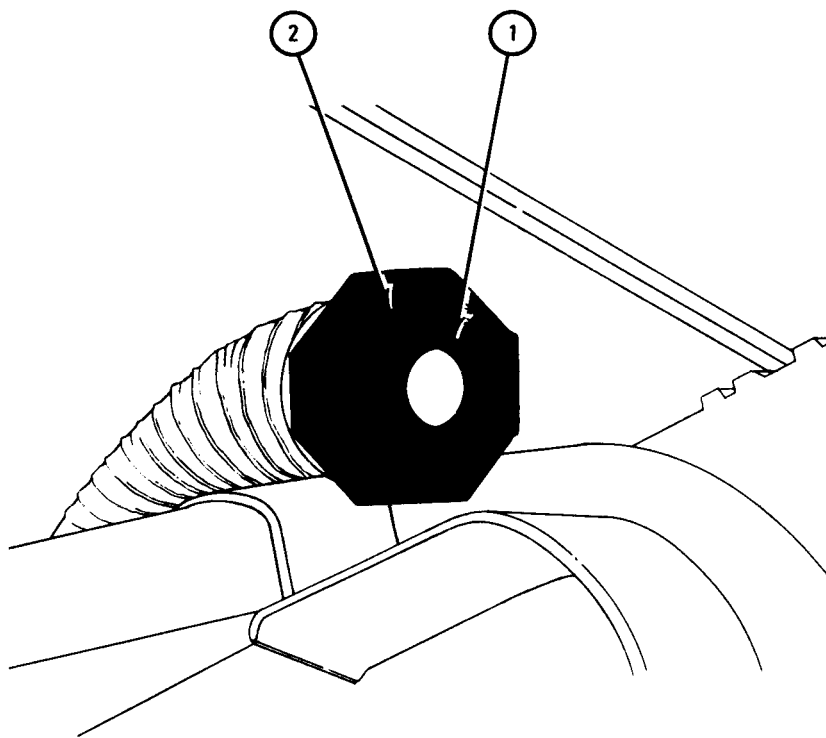

TA 083396

b. Replacement.

## FRAME 1

1. Seat gasket (1) in coupling nut (2).

GO TO FRAME 2

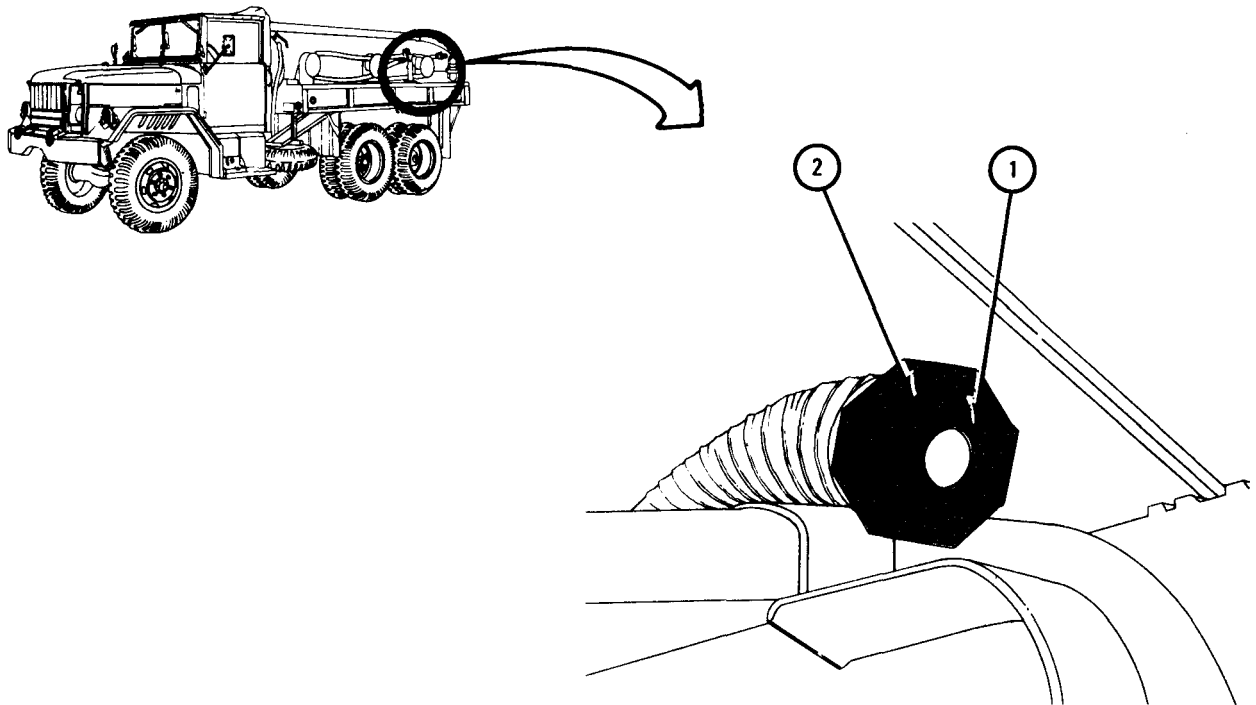

TA 083397

FRAME 2

1. Screw coupling nut (1) onto pipe (2). Using 2 11/16-inch wrench, hold nut (3). Using 2 1/4-inch wrench, tighten coupling nut onto pipe.

END OF TASK

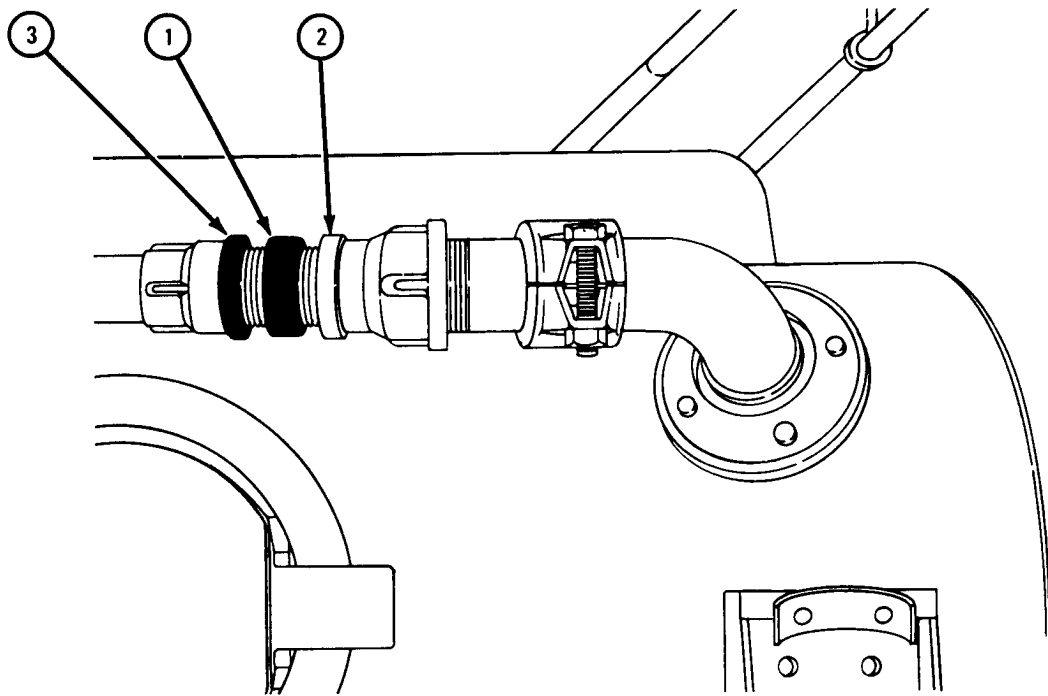

TA 083398

## 18-50. HOSE COUPLING GASKET REMOVAL AND REPLACEMENT (TRUCK M49A2C).

WARNING

Smoking, sparks or open flame are not allowed within 50 feet of work area during this task. Fuel may burn and cause an explosion, resulting in injury to personnel and damage to equipment.

TOOLS: Adjustable wrench  
Spanner wrench

SUPPLIES: Gasket

PERSONNEL: One

EQUIPMENT CONDITION: Truck parked, engine off, handbrake set.

a. Removal.

FRAME 1

## NOTE

Some hoses may have spring (1) on the end. The procedure is the same for both hoses.

1. Using spanner wrench, hold fitting (2). Using adjustable wrench, unscrew coupling nut (3).
2. Take out hose (4) from fitting (2).

GO TO FRAME 2

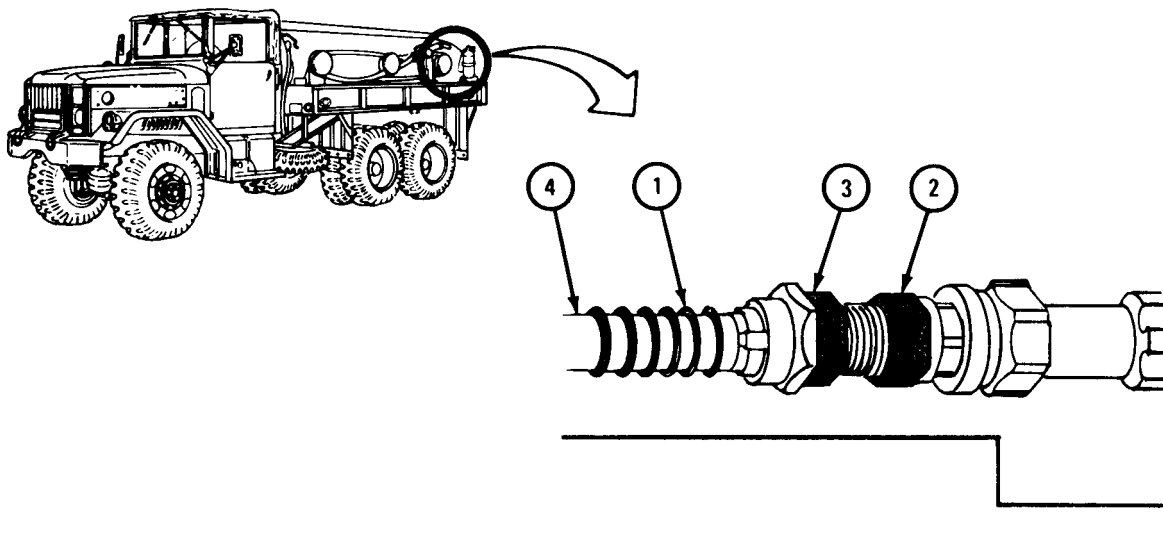

TA 101558

FRAME 2

1. Take gasket (1) out of coupling nut (2). Throw gasket away.

END OF TASK

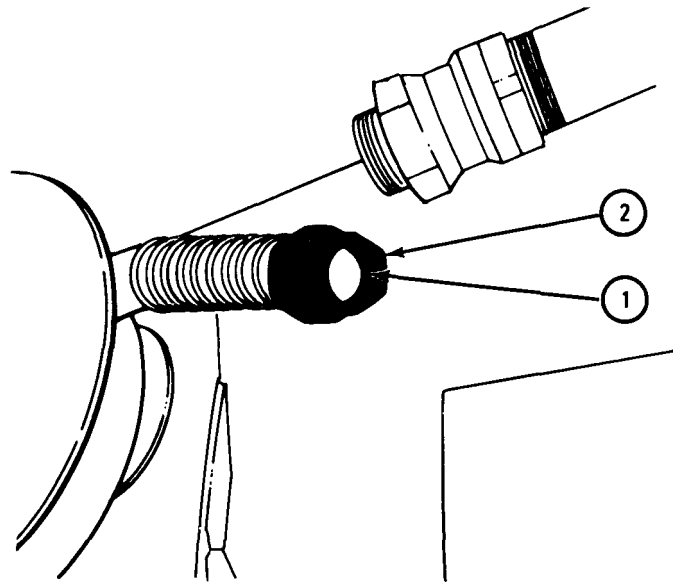

TA 046596



b. Replacement.

## FRAME 1

1. Put gasket (1) into coupling nut (2) and seat gasket.

GO TO FRAME 2

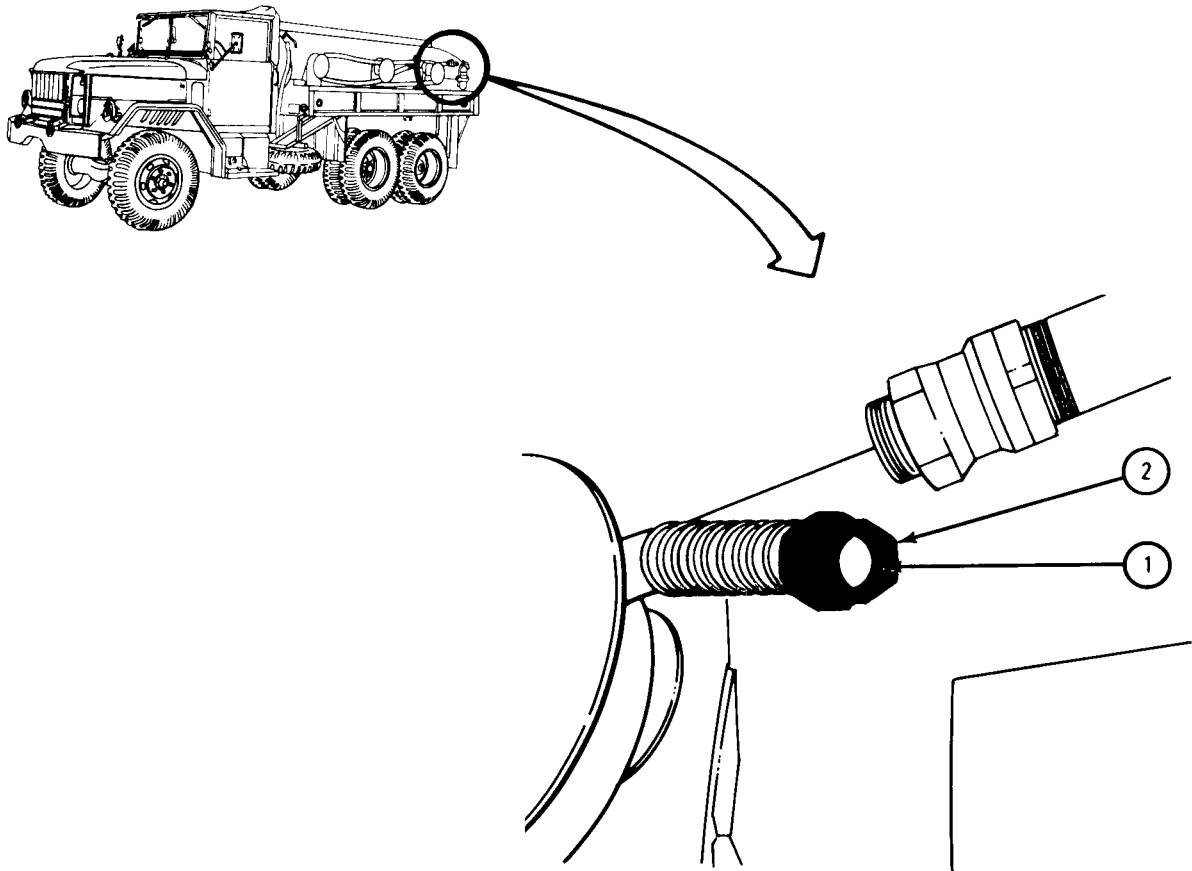

TA 046597

FRAME 2

1. Screw coupling nut (1) onto fitting (2). Using spanner, hold fitting. Using adjustable wrench, tighten coupling nut.

END OF TASK

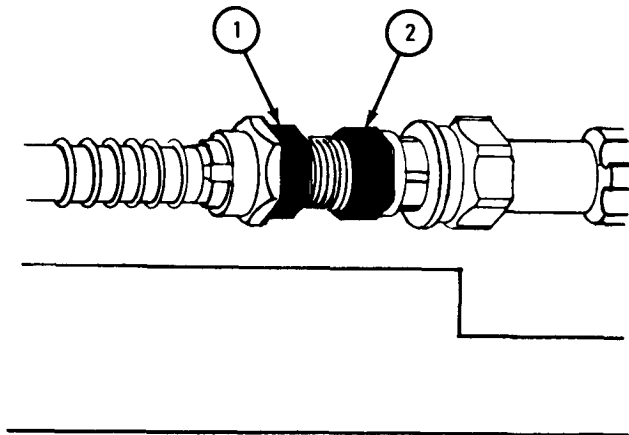

TA 101559

18-51. MANHOLE COVER REMOVAL AND REPLACEMENT (TRUCKS M49A1C AND M49A2C).

TOOLS: 9/16-inch wrench (2)  
Scraper

SUPPLIES: Manhole cover gasket  
Solvent, dry cleaning, type II (SD-2), Fed. Spec P-D-680  
Rags

PERSONNEL: One

EQUIPMENT CONDITION: Truck parked, engine off, handbrake set.

WARNING

Smoking, open flame, sparks, and glowing or hot objects are not allowed within 50 feet of work area. Fuel may catch fire and explode, causing injury to personnel and damage to equipment.

a. Removal.

FRAME 1

1. Using wrenches, hold screw (1) and unscrew and take off nut (2) and washer (3). Take out screw.
2. Take off clamp ring (4). Take off manhole cover (5). Take off gasket (6) and throw it away.

END OF TASK

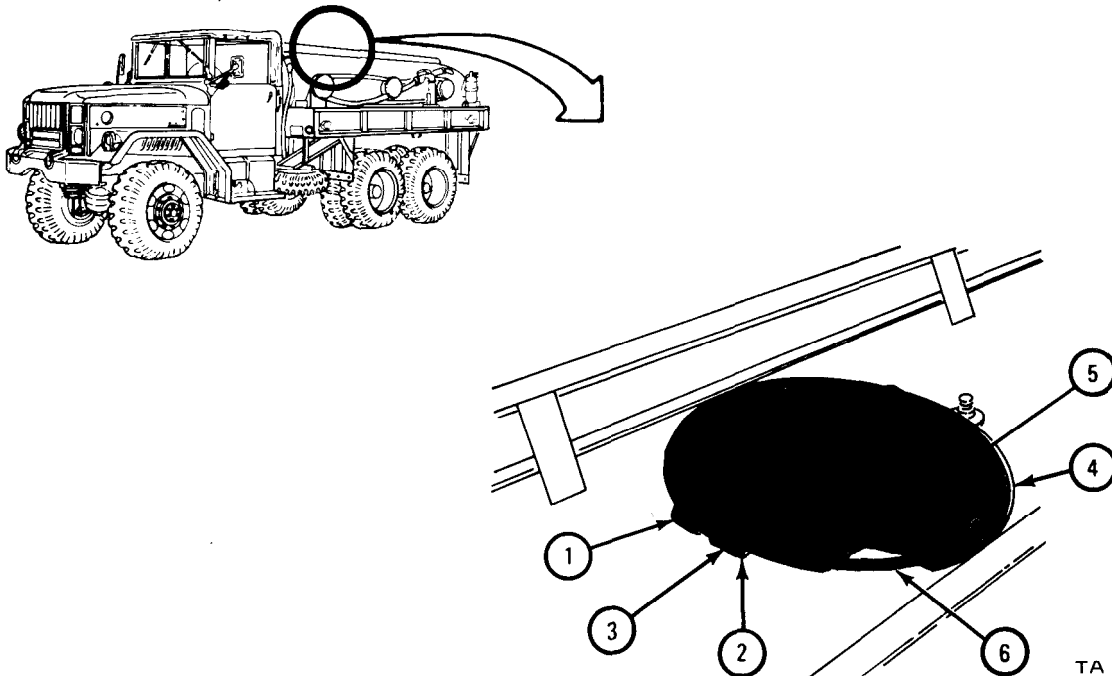

TA 046409

b. Replacement.

FRAME 1

WARNING

Dry cleaning solvent is flammable. Do not use near an open flame. Keep a fire extinguisher nearby when solvent is used. Use only in well-ventilated places. Failure to do this may result in injury to personnel and damage to equipment.

1. Using solvent, clean manhole cover (1) around where gasket (2) was. Use scraper, if needed, to get rid of all of old gasket pieces.
2. Using solvent, clean around manhole where gasket (2) was. Use scraper, if needed, to get rid of all old gasket pieces. Do not let any gasket pieces fall into tank.
3. Put new gasket (2) in place. Put manhole cover (1) down on gasket.
4. Hold clamp ring (3) open and put it on manhole cover (1). Make sure it catches manhole cover and truck all around.
5. Put screw (4) through clamp ring (3) and using wrench, hold it. Put washer (5) on screw. Using wrench, screw on and tighten nut (6).

END OF TASK

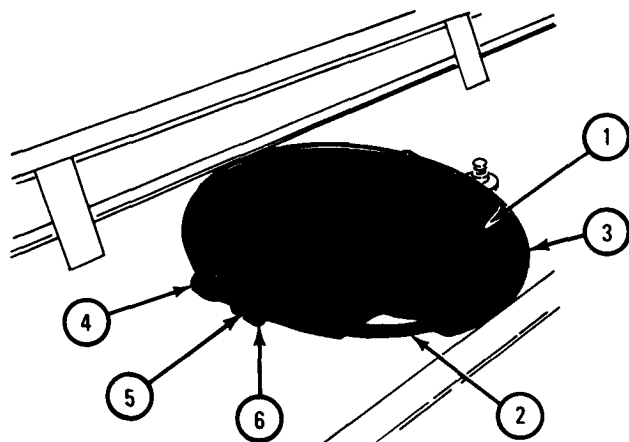
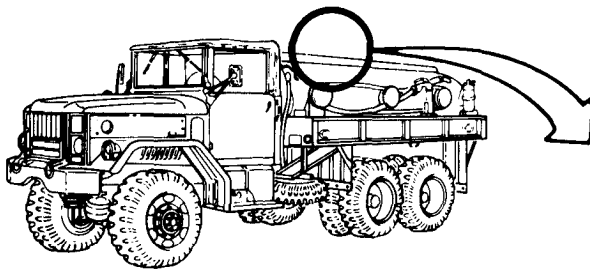

TA 046410

## 18-52. MANHOLE COVER REPAIR.

TOOLS: Spanner wrench, 4-inch span

SUPPLIES: None

PERSONNEL: One

EQUIPMENT CONDITION: Truck parked, engine off, handbrake set.

- a. Preliminary Procedure. Remove manhole cover. Refer to para 18-51.
- b. Disassembly.

## FRAME 1

1. Using spanner wrench, unscrew and take out valve (1) with washer (2).
2. Take off cover (3), gasket (4), and retainer (5).

END OF TASK

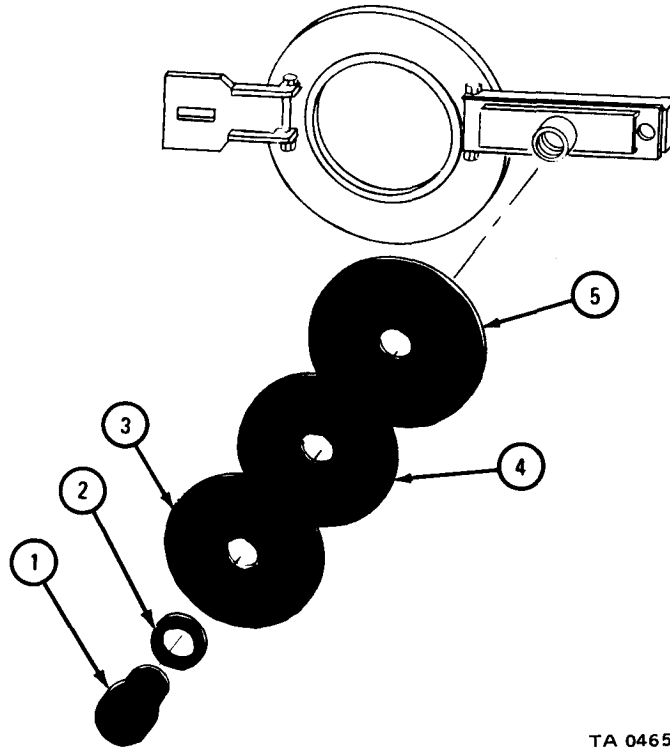

TA 046589

c. Inspection and Repair. Check all parts for damage. Throw away damaged parts. Get new parts in their place.

d. Assembly.

FRAME 1

1. Put washer (1) on vent valve (2).
2. Put cover (3), gasket (4), and retainer (5) on vent valve (2). Screw vent valve into arm (6). Using spanner wrench, tighten vent valve.

NOTE

Follow-on Maintenance Action Required:  
Replace manhole cover. Refer to para 18-51.

END OF TASK

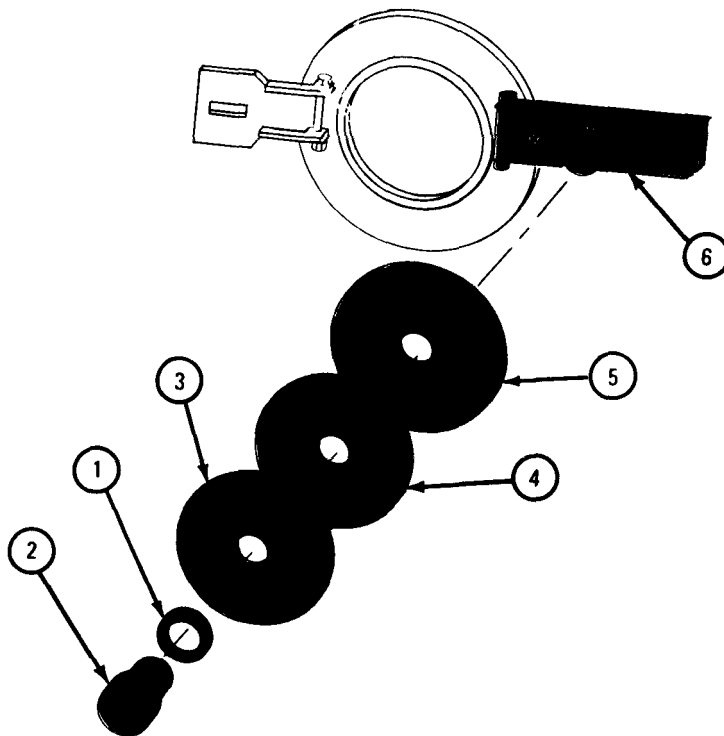

TA 046590

18-53. DISCHARGE VALVE REMOVAL AND REPLACEMENT (TRUCKS M50A1, M50A2, AND M50A3).

NOTE

This task is shown for the front discharge valve.  
This task is the same for the front and rear discharge valves.

TOOLS: 9/16-inch open-end wrench (2)  
Cross-tip screwdriver (Phillips type)  
Pliers  
9/16-inch socket  
10-inch extension  
Universal joint  
Ratchet

SUPPLIES: Discharge valve gasket  
Discharge valve-to-tank drain pipe gasket

PERSONNEL: Two

EQUIPMENT CONDITION: Truck parked, engine off, handbrake set.

a. Preliminary Procedure. Drain water from tank body. Refer to  
TM 9-2320-209-10.

b. Removal.

FRAME 1

Soldier A 1. Using 9/16-inch wrench, hold three capscrews (1).

Soldier B 2. Using 9/16-inch wrench, unscrew and take off three nuts (2) and washers (3).

Soldier A 3. Take out three capscrews (1). Go to front of cover (4).

GO TO FRAME 2

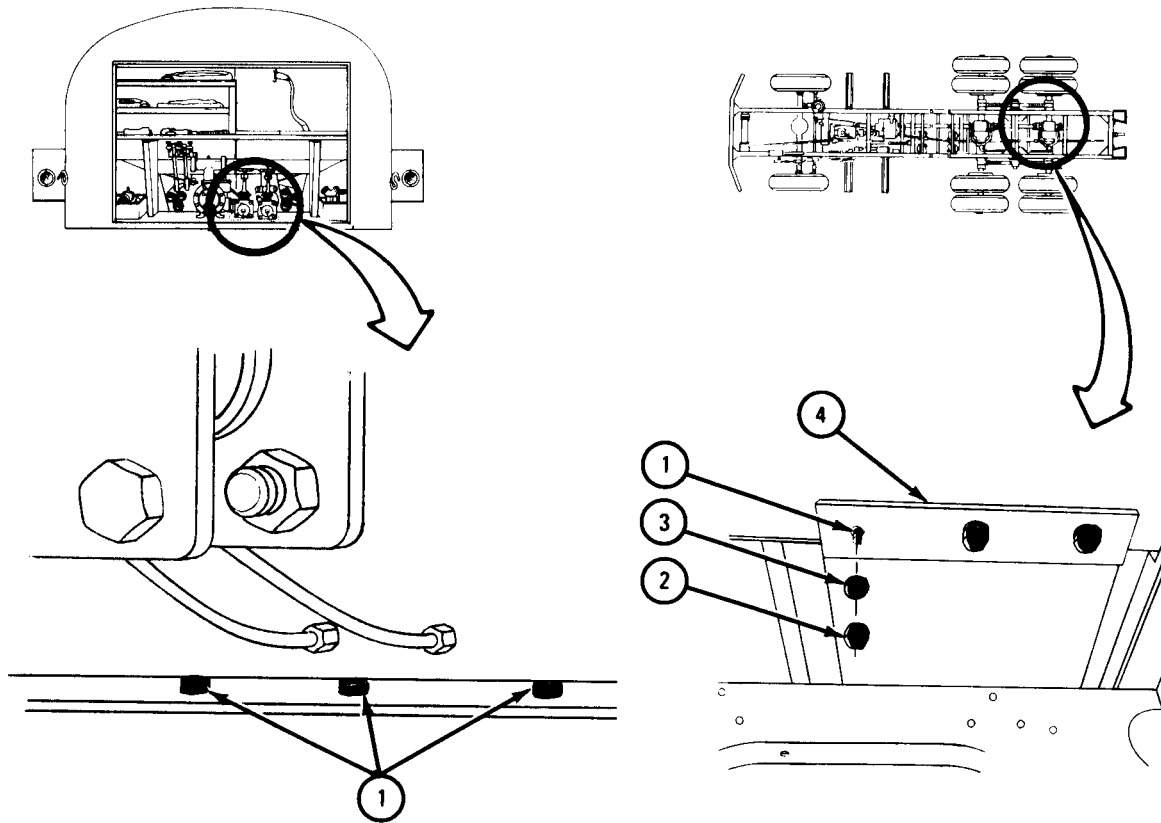

TA 080806



FRAME 2

- Soldier A
1. Using 9/16-inch wrenches, hold three capscrews (1) and unscrew and take off three nuts (2) and lockwashers (3).
  2. Take out three capscrews (1).
  3. Hold up drain pipe cover (4).
- Soldier B
4. Using screwdriver, unscrew and take out two screws (5). Go to rear of truck.

GO TO FRAME 3

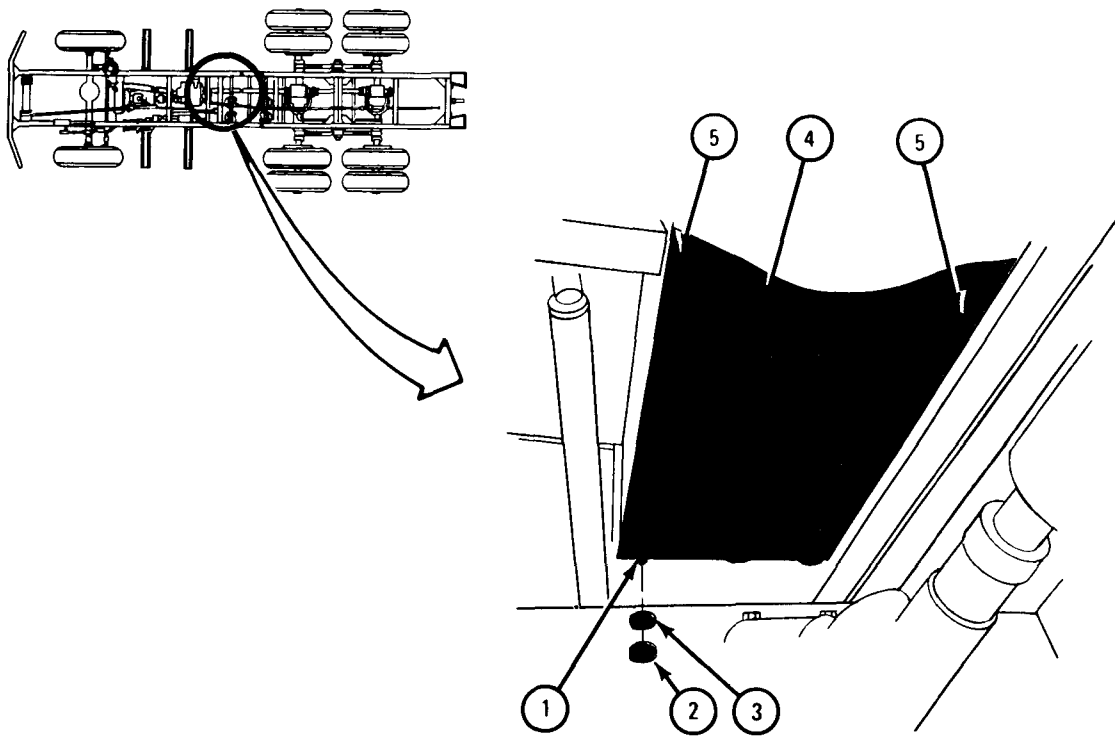

TA 080805

FRAME 3

1. Using screwdriver, unscrew and take out two screws (1) from drain pipe cover (2).

Soldiers A and B

2. Slide cover (2) to left side of truck.

GO TO FRAME 4

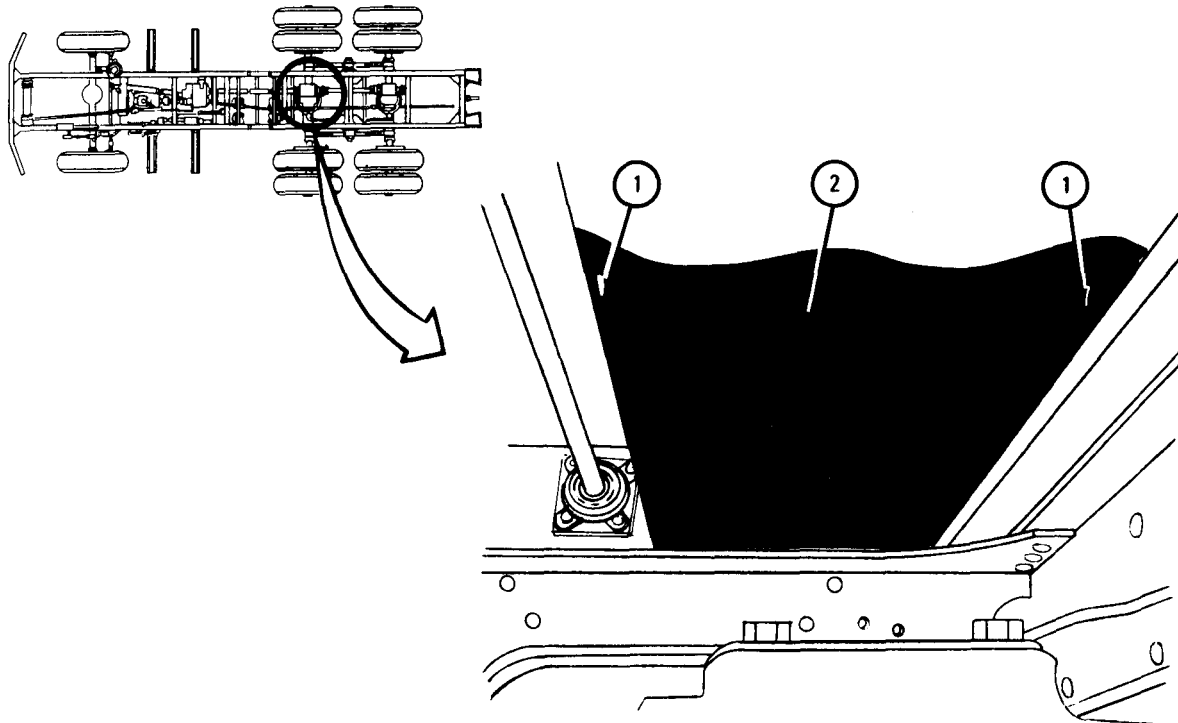

TA 080804

## FRAME 4

- Soldier A 1. Using pliers, pull out and throw away cotter pin (1). Slide off arm (2).
2. Using 9/16-inch wrench, hold six cap screws (3).
- Soldier B 3. Using 9/16-inch socket wrench, extension, universal joint, and ratchet, unscrew and take off six nuts (4).
- Soldier A 4. Take out six capscrews (3).
5. Hold discharge valve (5) in place.
- Soldier B 6. Using 9/16-inch wrenches, unscrew and take out six capscrews (6) and flat washers (7).
- Soldiers A and B 7. Take out discharge valve (5) and two gaskets (8). Throw away two gaskets.

END OF TASK

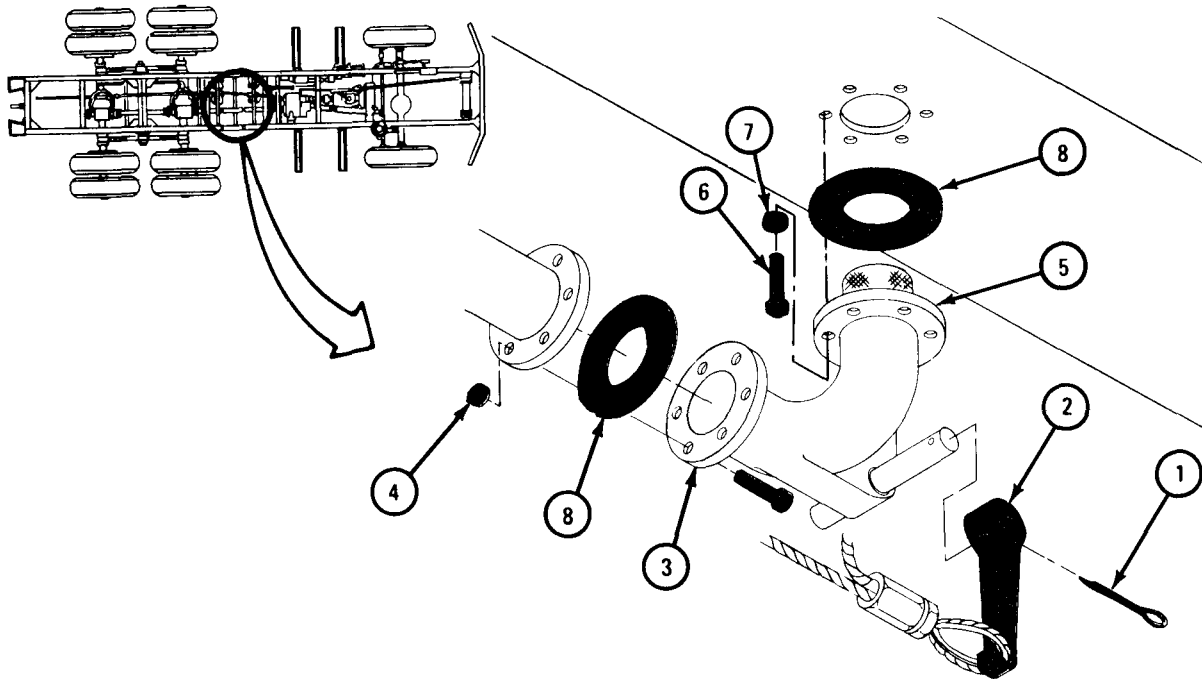

TA 080807

c. Replacement.

FRAME 1

1. Put on gasket (1) as shown.
- Soldier A 2. Put discharge valve (2) in place and hold it there.
- Soldier B 3. Using 9/16-inch wrench, screw in and tighten six capscrews (3) and flat washers (4).
4. Put gasket (5) between drain pipe (6) and discharge valve (2).
5. Aline holes and put in six cap screws (7). Using 9/16-inch wrench, hold capscrews.
- Soldier A 6. Using 9/16-inch socket, extension, universal joint, and ratchet, screw on and tighten six nuts (8).
7. Slide arm (9) into place, alining holes for cotter pin (10).
8. Put in cotter pin (10). Using pliers, bend open ends of cotter pin.

GO TO FRAME 2

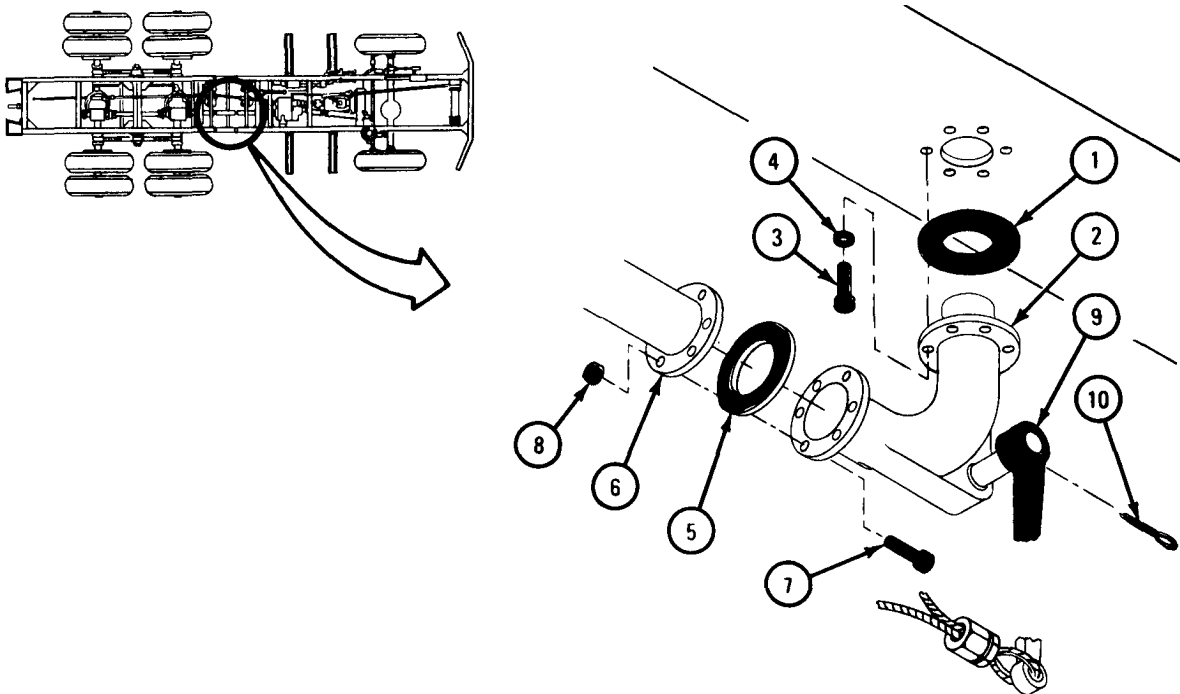

TA 080808

## FRAME 2

Soldiers 1. Slide drain pipe cover (1) in place as shown.  
A and B

Soldier A 2. Hold drain pipe cover (1) in place.

Soldier B 3. Aline holes in drain pipe cover (1) and brackets (2). Using screwdriver, screw in and tighten two screws (3). Go to front of truck.

GO TO FRAME 3

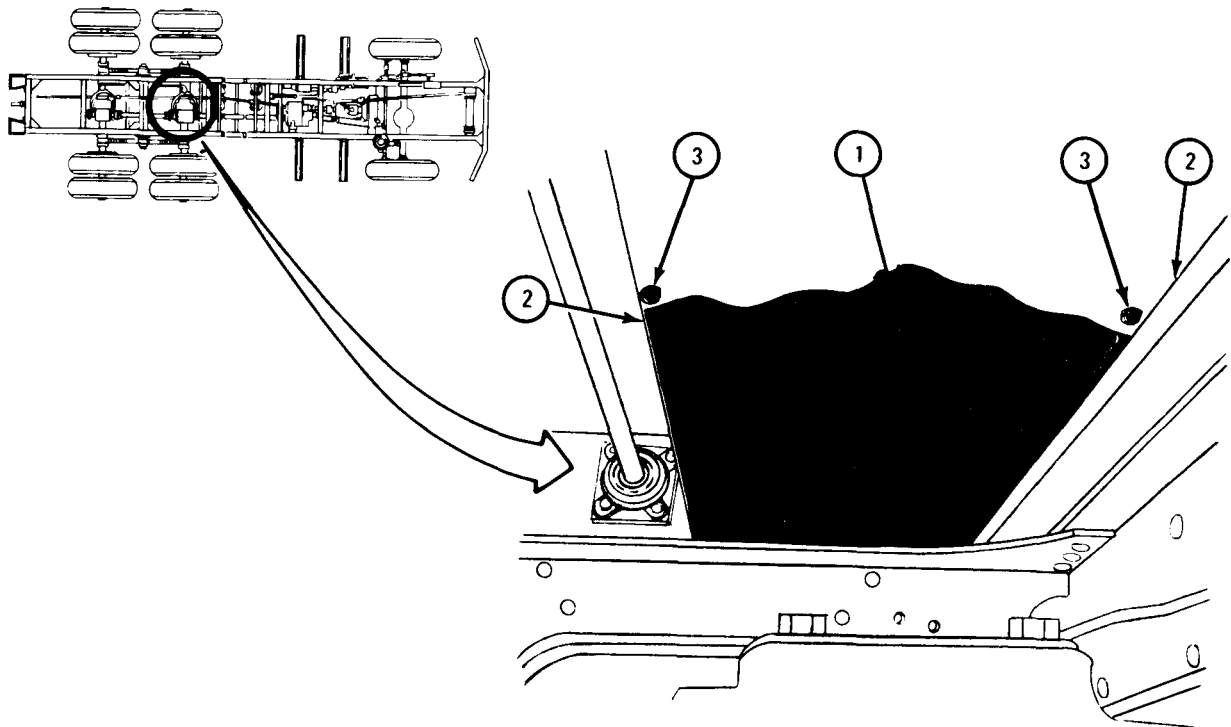

TA 080811

FRAME 3

Soldier B 1. Aline holes in drain pipe cover (1) and brackets (2). Using screwdriver, screw in and tighten two screws (3).

Soldier A 2. Put three capscrews (4) through holes and using 9/16-inch wrench, hold them.

Soldier B 3. Using 9/16-inch wrench, screw on and tighten three nuts (5) and washers (6). Go to back of truck.

GO TO FRAME 4

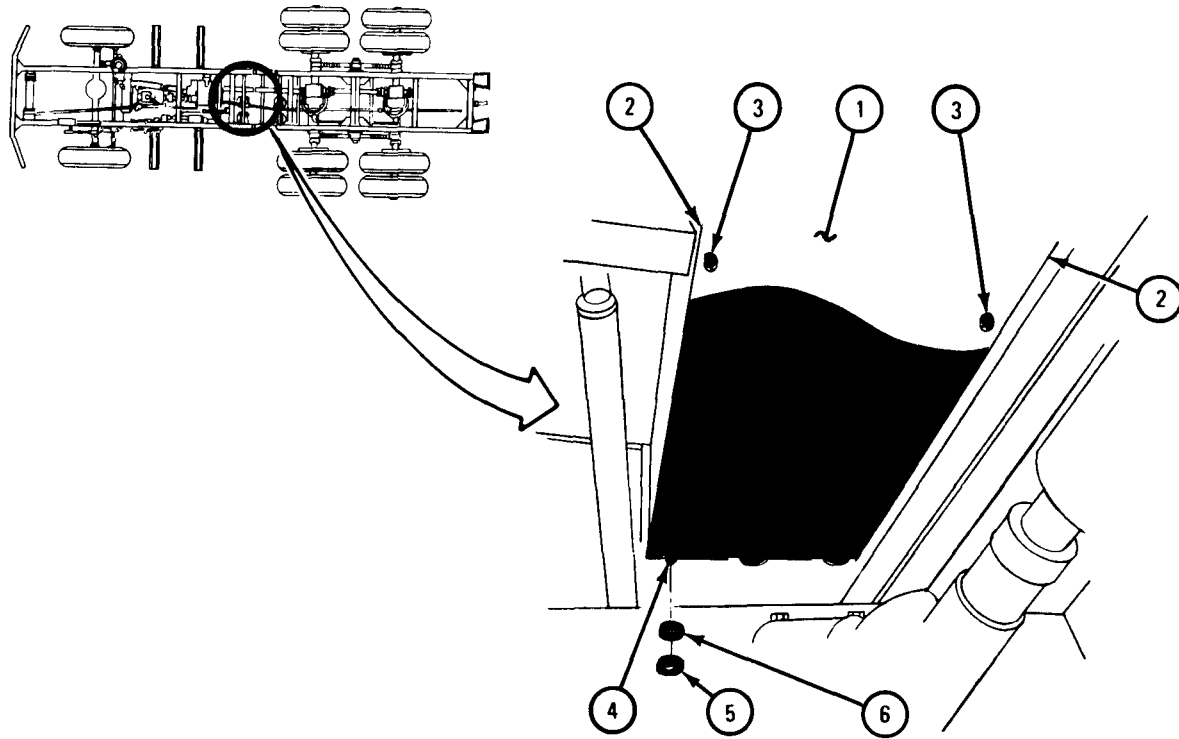

TA 080810

FRAME 4

Soldier A 1. Put in three capscrews (1) and hold them using 9/16-inch wrench.

Soldier B 2. Using 9/16-inch wrench, screw in and tighten three nuts (2) and washers (3).

NOTE

Follow-on Maintenance Action Required:  
Fill water tanks. Refer to TM 9-2320-209-10.

END OF TASK

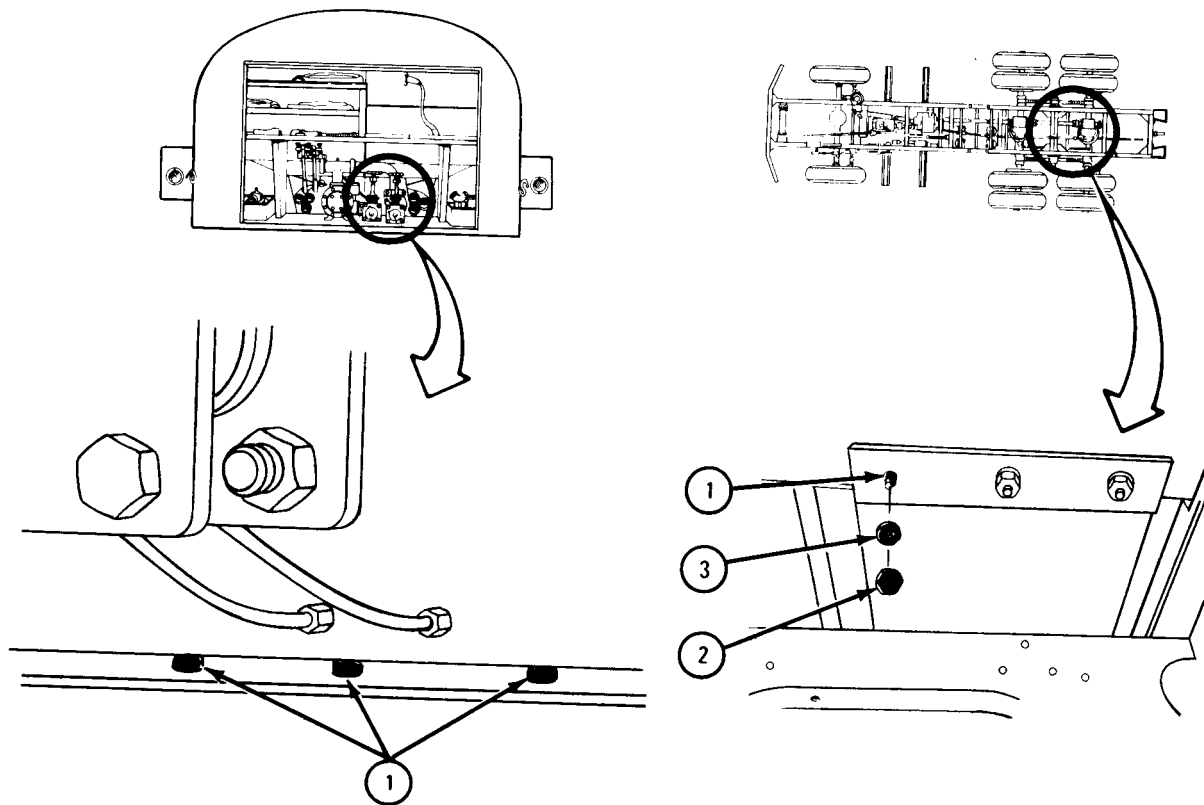

TA 080809

18-54. DISCHARGE VALVE PACKING REMOVAL AND REPLACEMENT (TRUCKS M50A1, M50A2, AND M50A3).

NOTE

Truck M50A1 has three discharge valves, one for each compartment. Trucks M50A2 and M50A3 have two discharge valves, one for each compartment. This task can be used for all valves.

TOOLS: Pliers  
1 3/8-inch wrench  
Pick

SUPPLIES: Discharge valve preformed packing

PERSONNEL: One

EQUIPMENT CONDITION: Truck parked, engine off, handbrake set.

a. Preliminary Procedures.

(1) Empty water from compartment for discharge valve being worked on. Refer to TM 9-2320-209-10

(2) Refer to discharge valve removal, para 18-53, for removal of bottom cover plate under tank section of chassis.

b. Removal.

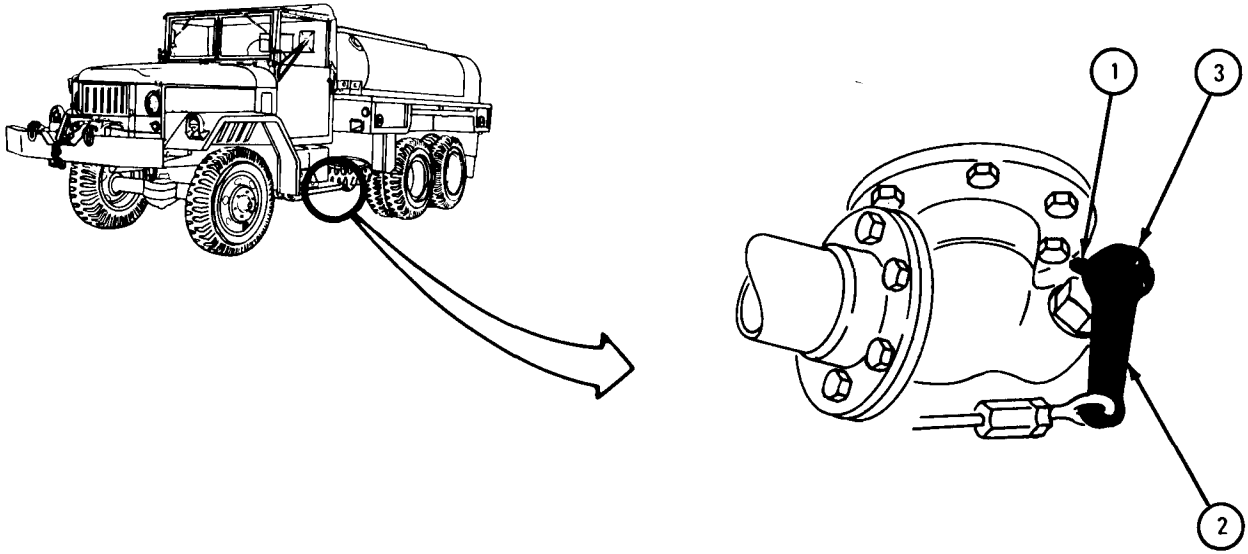
FRAME 1
<p>1. Working under truck and using pliers, take out and throw away cotter pin (1).</p> <p>2. Slide lever (2) off stem (3).</p> <p>GO TO FRAME 2</p>  <p>The diagram consists of two parts. On the left, a line drawing of a truck is shown from a front-three-quarter view. A circular callout with the number '1' is positioned under the truck's chassis, with a large arrow pointing to the right. On the right, a detailed line drawing of a discharge valve assembly is shown. It features a cylindrical stem with a lever attached to its side. Three callouts are present: '1' points to a cotter pin inserted through the stem, '2' points to the lever, and '3' points to the stem itself.</p>

TA 084044



## FRAME 2

1. Using wrench, unscrew and take off stem packing plug (1).
2. Using pick, take stem packing (2) out of valve body (3). Throw away stem packing.

END OF TASK

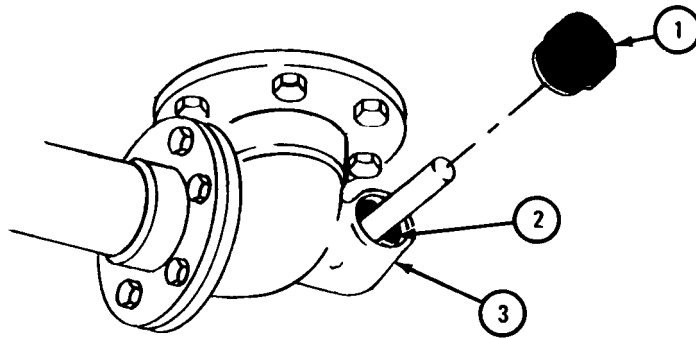

TA 046429

c. Replacement.

FRAME 1

1. Working under truck, put stem packing (1) on water tank discharge valve stem (2).
2. Put packing plug (3) on stem (2). Using packing plug as tool, push stem packing (1) into valve body (4).
3. Using wrench, screw in packing plug (3).

GO TO FRAME 2

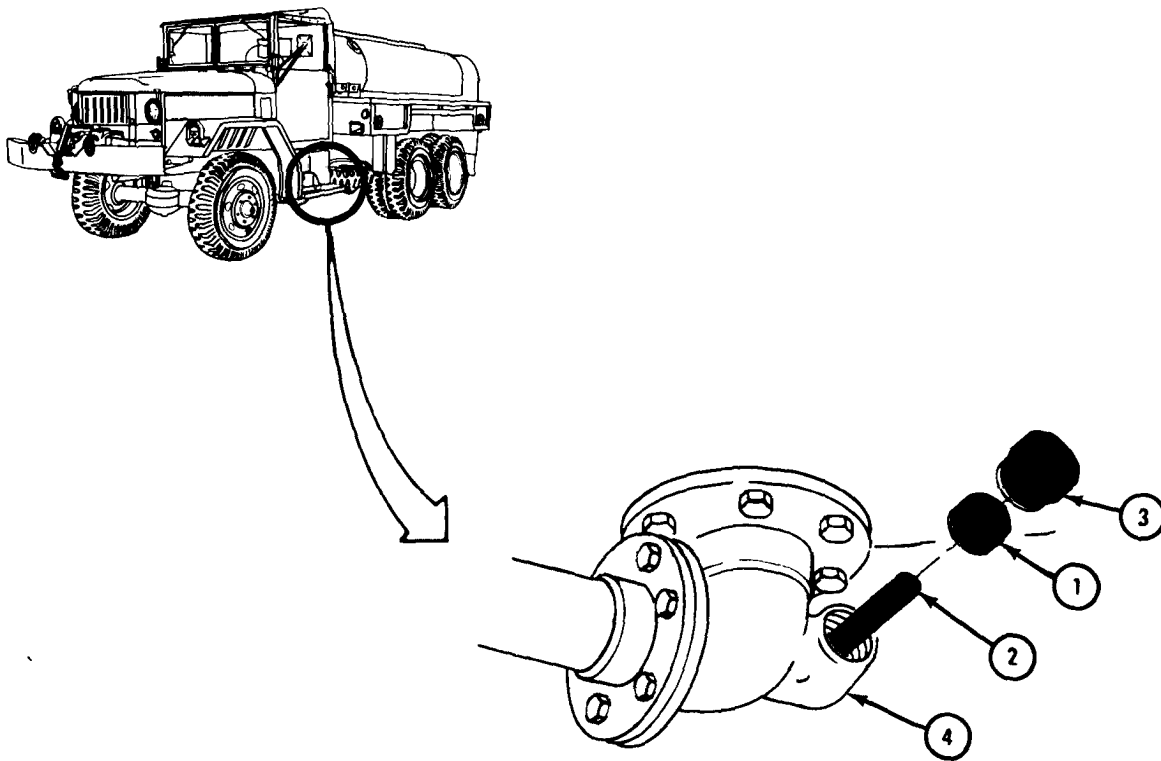

TA 084045

## FRAME 2

1. Put lever (1) onto stem (2). Line up holes for cotter pin (3).
2. Put cotter pin (3) through holes in lever (1) and stem (2). Using pliers, bend open ends of cotter pin.

## NOTE

Follow-on Maintenance Action Required:

Refer to discharge valve replacement, para 18-53, for replacement of bottom cover plate under tank section of chassis.

END OF TASK

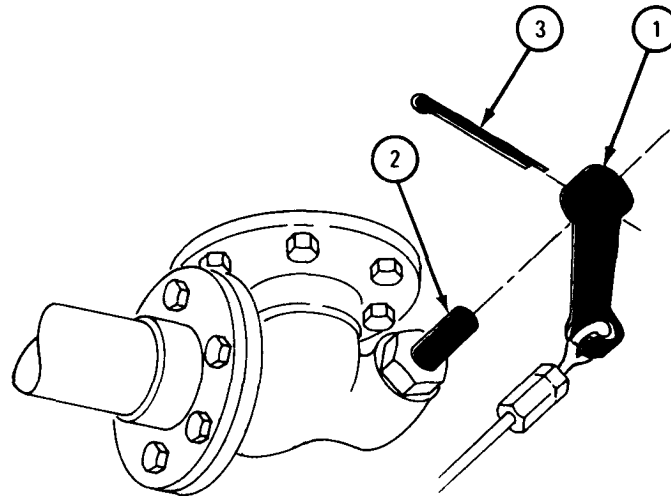

TA 046431

18-55. DISCHARGE VALVE CONTROL LEVERS REMOVAL AND REPLACEMENT  
(TRUCKS M50A1, M50A2, AND M50A3).

TOOLS: 1/2-inch open end wrench  
5/8-inch wrench  
7/16-inch wrench (2)  
Pliers  
Leather gloves

SUPPLIES: None

PERSONNEL: One

EQUIPMENT CONDITION: Truck parked, engine off, handbrake set.

WARNING

Always wear protective gloves when handling cable. Do not let cable slip through hands. Rusty or broken wires can cause injury.

- a. Preliminary Procedure. Open rear compartment doors.
- b. Removal.

FRAME 1

1. Using 1/2-inch open end wrench, unscrew two nuts (1) until two cables (2) are free.
2. Pull two cables (2) out of two bolts (3).

GO TO FRAME 2

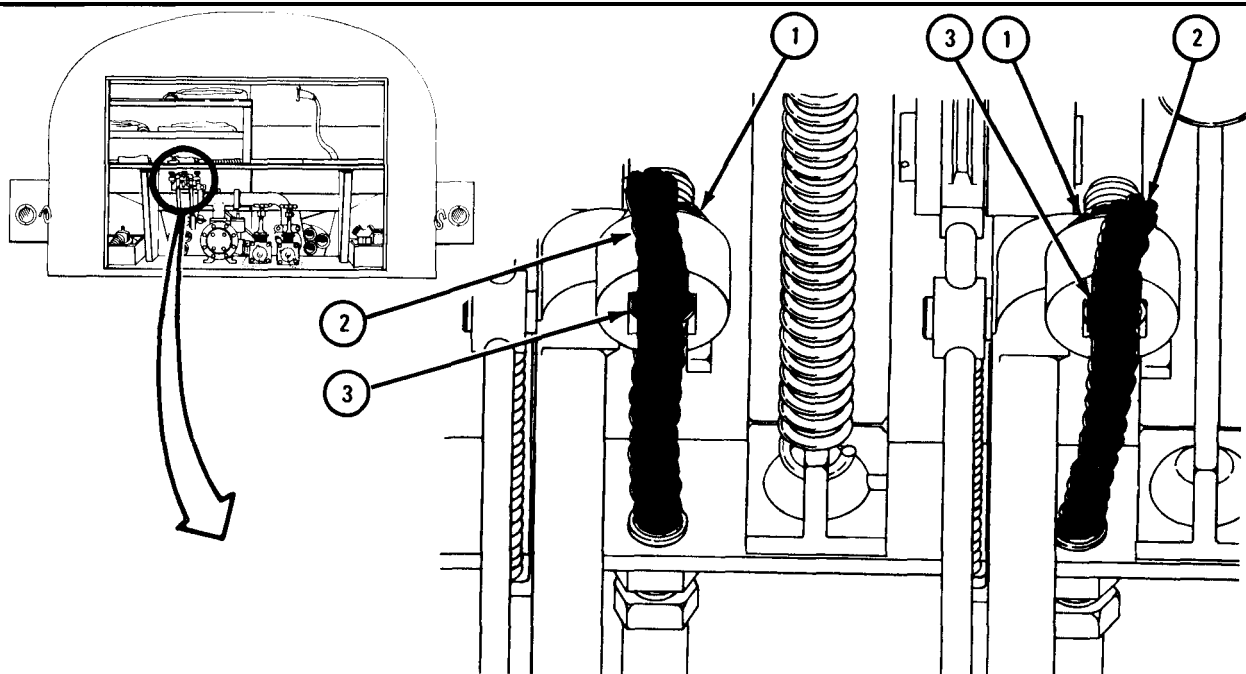

TA 083374

## FRAME 2

1. Using 5/8-inch open end wrench, hold fitting nut (1). Using 3/4-inch wrench, unscrew two coupling nuts (2). Slide coupling nuts back on tubes (3).
2. Using 7/16-inch wrenches, unscrew and take off six nuts (4) and six bolts (5).
3. Take out discharge valve operating lever assembly (6).

END OF TASK

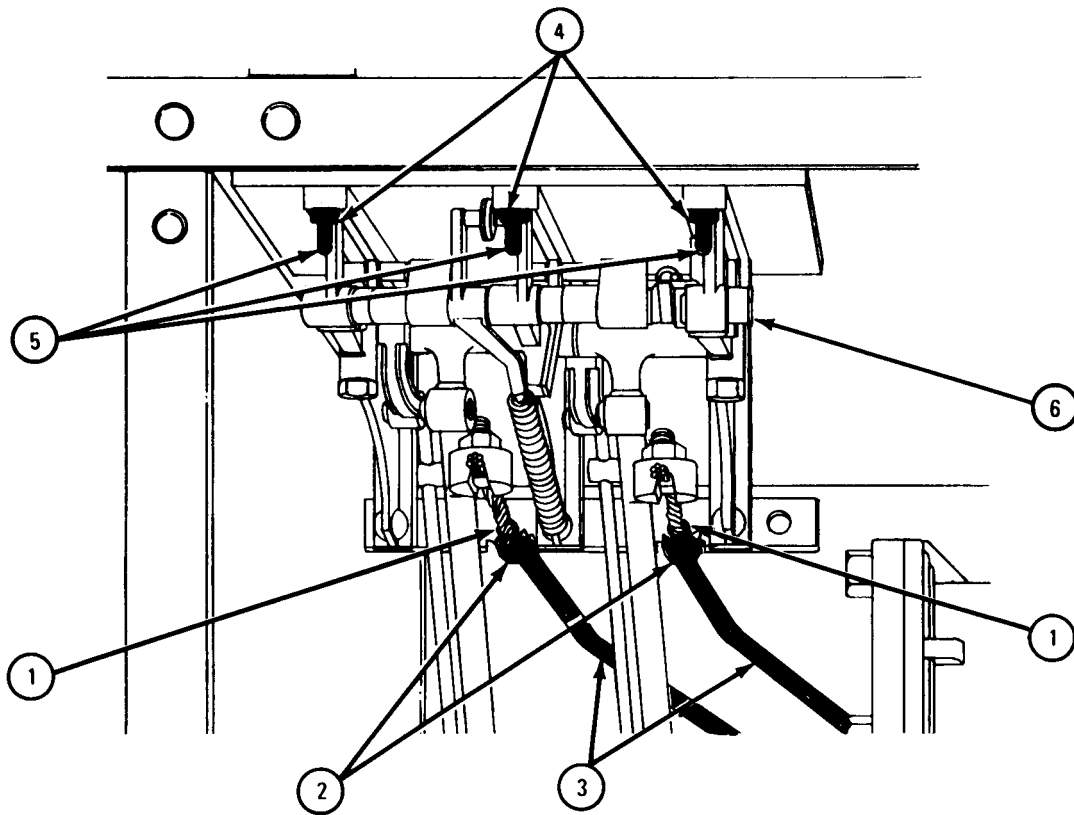

TA 083375

c. Replacement.

FRAME 1

1. Put discharge valve operating lever assembly (1) in place, feeding two cables (2) through holes in bracket (3).
2. Using 7/16-inch wrenches, screw in and tighten six bolts (4) and six nuts (5).
3. Using 5/8-inch open end wrench, hold two fitting nuts (6). Using 3/4-inch wrench, screw on and tighten two coupling nuts (7).

GO TO FRAME 2

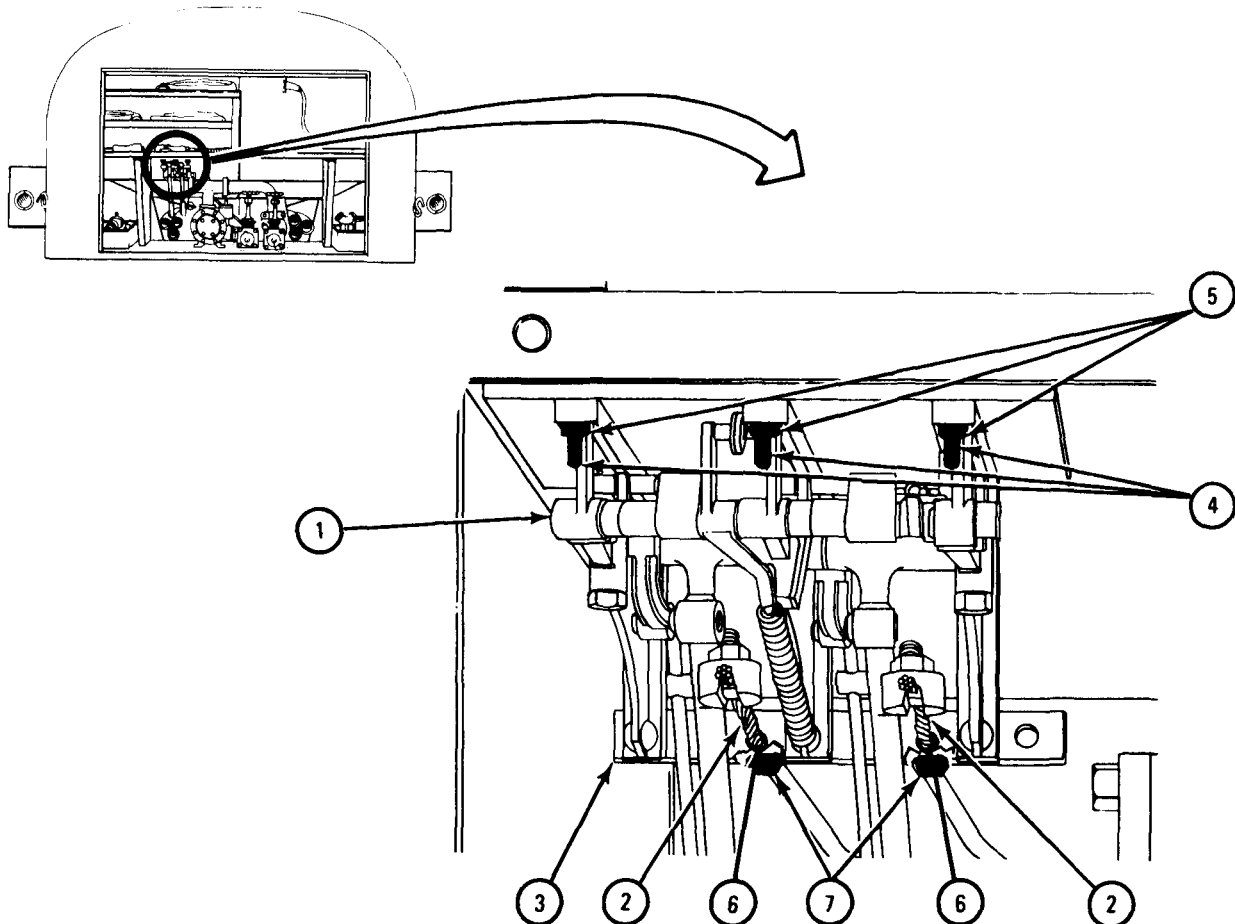

TA 083376

## FRAME 2

## NOTE

Make sure discharge valve operating levers (1) are in closed position.

1. Using pliers, pull two cable ends (2) through holes in two bolts (3).
2. Using pliers, pull cable ends (2) to take out slack. Using 1/2-inch wrench, tighten two nuts (4).

## NOTE

Follow-on Maintenance Action Required:

Close rear compartment doors.

END OF TASK

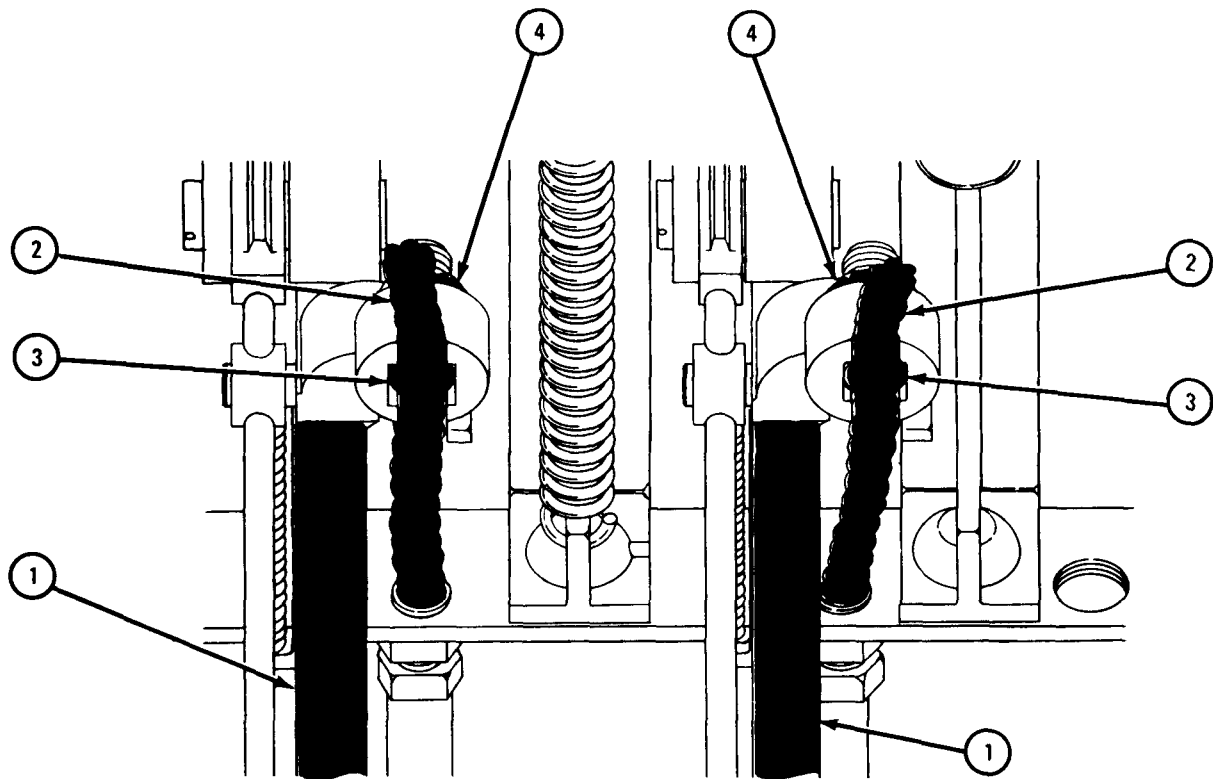

TA 083377

18-56. FRONT AND REAR DISCHARGE VALVE CABLES REMOVAL AND REPLACEMENT (TRUCKS M50A1, M50A2, AND M50A3).

TOOLS: 1/2-inch wrench  
7/8-inch wrench  
13/16-inch wrench  
Pliers

SUPPLIES: None

PERSONNEL: One

EQUIPMENT CONDITION: Truck parked, engine off, handbrake set.

a. Preliminary Procedure. Refer to discharge valve removal, para 18-53, for removal of bottom cover plate under tank section of chassis.

b. Removal.

(1) Rear discharge valve cable.

FRAME 1

1. Working under rear of tank using 13/16-inch wrench, hold split nut (1). Using 7/8-inch wrench, unscrew and slide back thimble (2). Take off split nut (1).
2. Pull end of cable (3) out of thimble (2) and through hole in rear discharge valve lever (4).
3. Take thimble (2) off cable (3).

GO TO FRAME 2

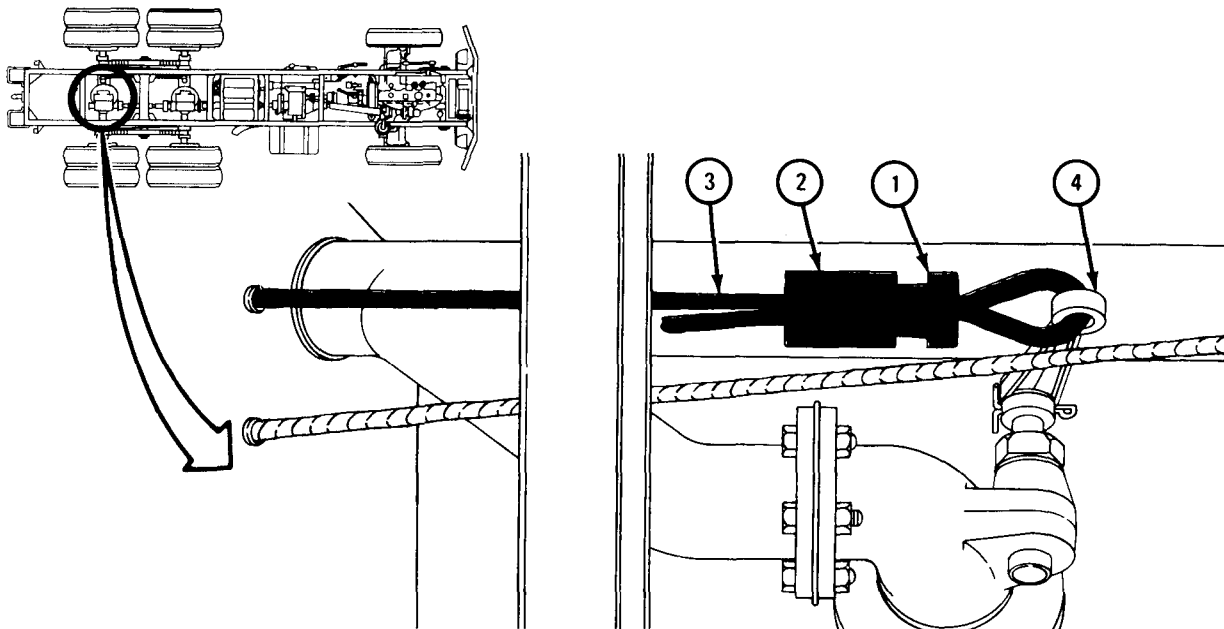

TA 083368



## FRAME 2

1. Open rear compartment doors.
2. Using 1/2-inch wrench, loosen nut (1) and pull end of cable (2) out of clamp bolt (3).
3. Pull cable (2) out of truck.

END OF TASK

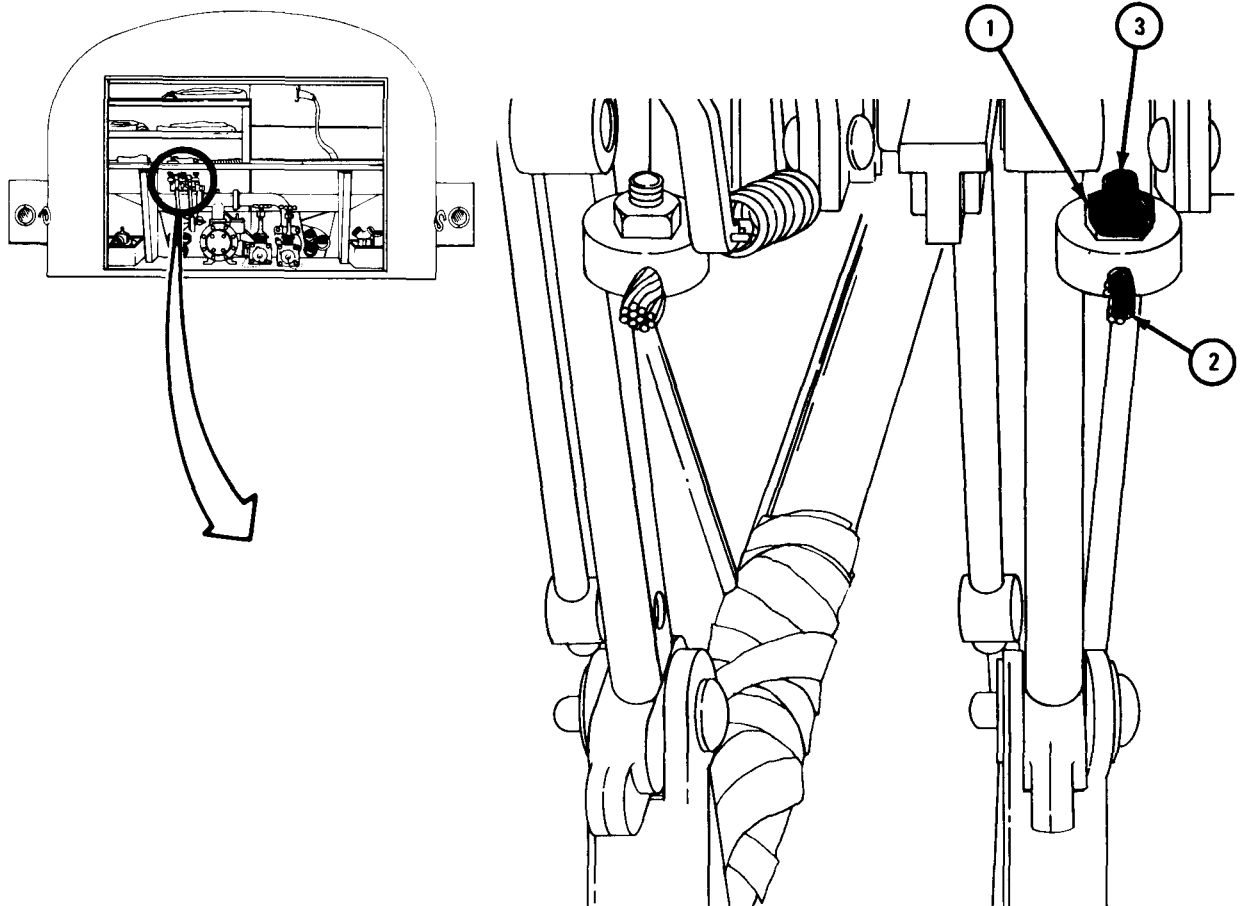

TA 083370

(2) Front discharge valve cable.

FRAME 1

1. Working under front of tank using 13/16-inch wrench, hold split nut (1). Using 7/8-inch wrench, unscrew and slide back thimble (2). Take off split nut (1).
2. Pull end of cable (3) out of thimble (2) and through hole in front discharge valve lever (4).
3. Take thimble (2) off cable (3).

GO TO FRAME 2

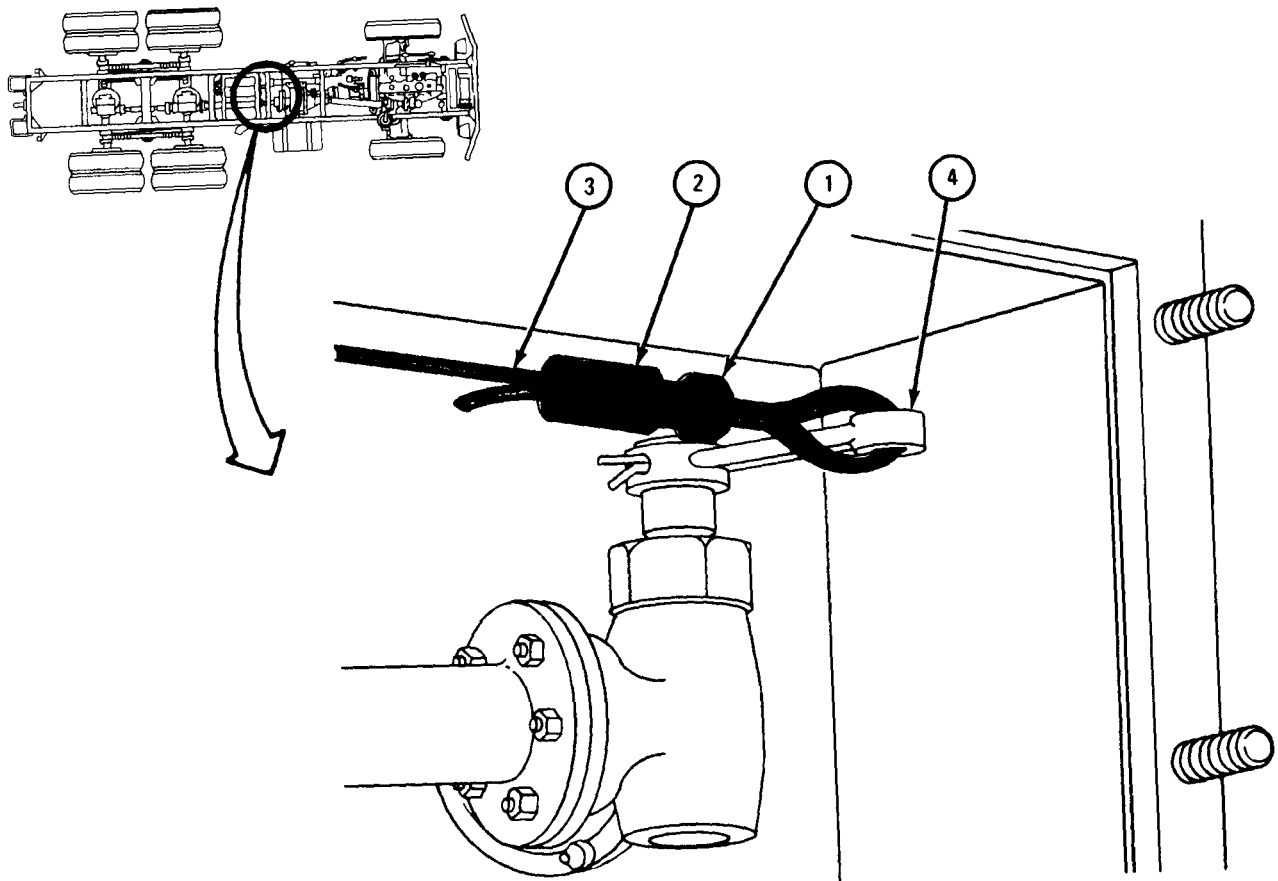

TA 083369

## FRAME 2

1. Open rear compartment doors.
2. Using 1/2-inch wrench, loosen nut (1) and pull end of cable (2) out of clamp bolt (3).
3. Pull cable (2) out of truck.

END OF TASK

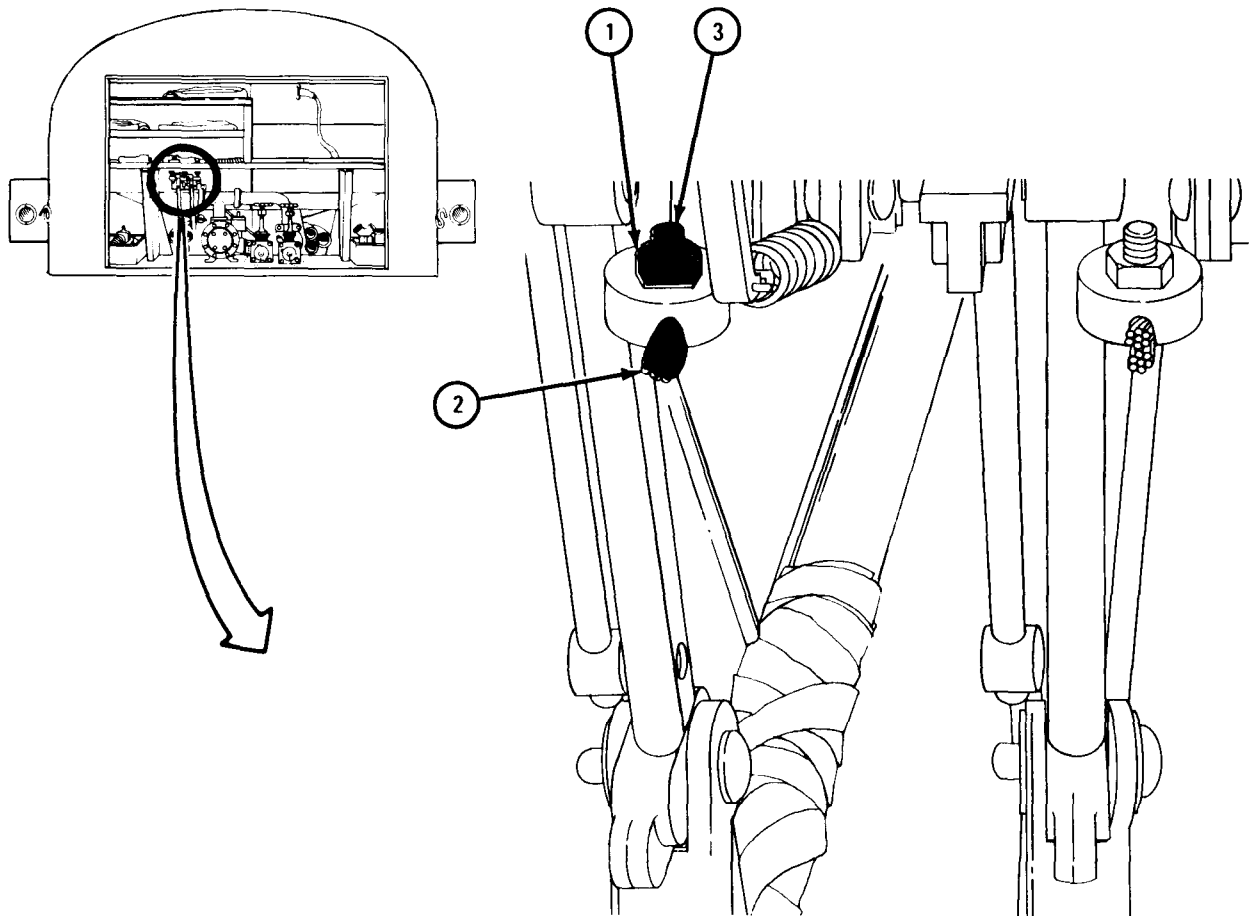

TA 083390

c. Replacement.

(1) Rear discharge valve cable.

FRAME 1

1. Slide thimble (1) on end of cable (2).
2. Working under rear of tank, put end of cable (2) around eye (3) in discharge valve lever (4) and back through thimble (1), as shown.
3. Put split nut (5) over cable (2) between thimble (1) and eye (3) as shown.
4. Using pliers, hold split nut (5) together. Screw on thimble (1).
5. Using 13/16-inch and 7/8-inch wrenches, hold split nut (5) and tighten thimble (1).
6. Push other end of cable (2) through hole in wall (6) and push all slack in cable through hole.

GO TO FRAME 2

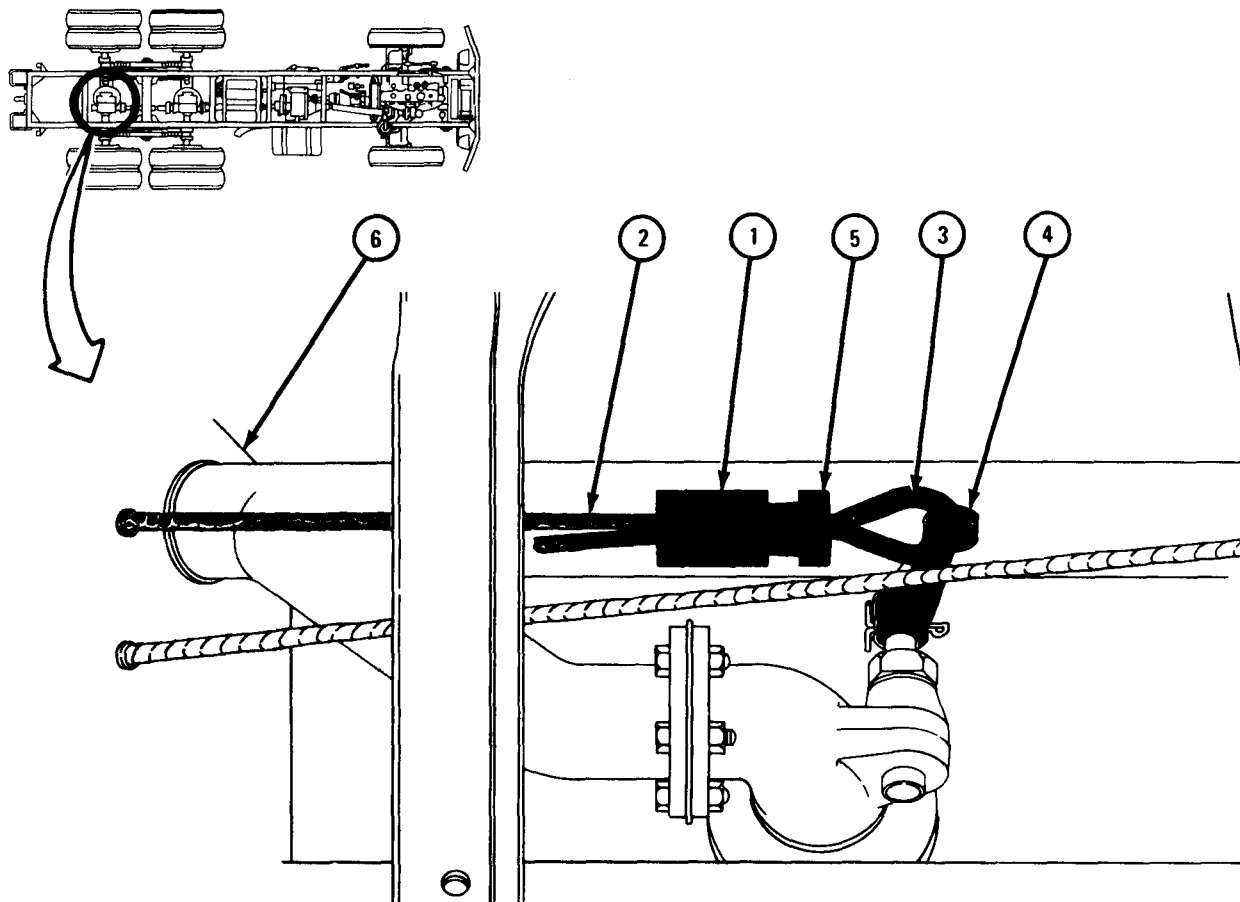

TA 083372

## FRAME 2

1. Put rear discharge lever (1) in forward (off) position.
2. Using pliers, pull cable (2) through hole in bolt (3) until all slack is out of cable.

CAUTION

Do not put any tension on cable (2) when tightening nut (4).

3. Using 1/2-inch wrench, tighten nut (4).

NOTE

Follow-on Maintenance Action Required:

1. Lubricate tubes. Refer to LO 9-2320-209-12/1.
2. Refer to discharge valve replacement, para 18-53, for replacement of bottom cover plate under tank section of chassis.

END OF TASK

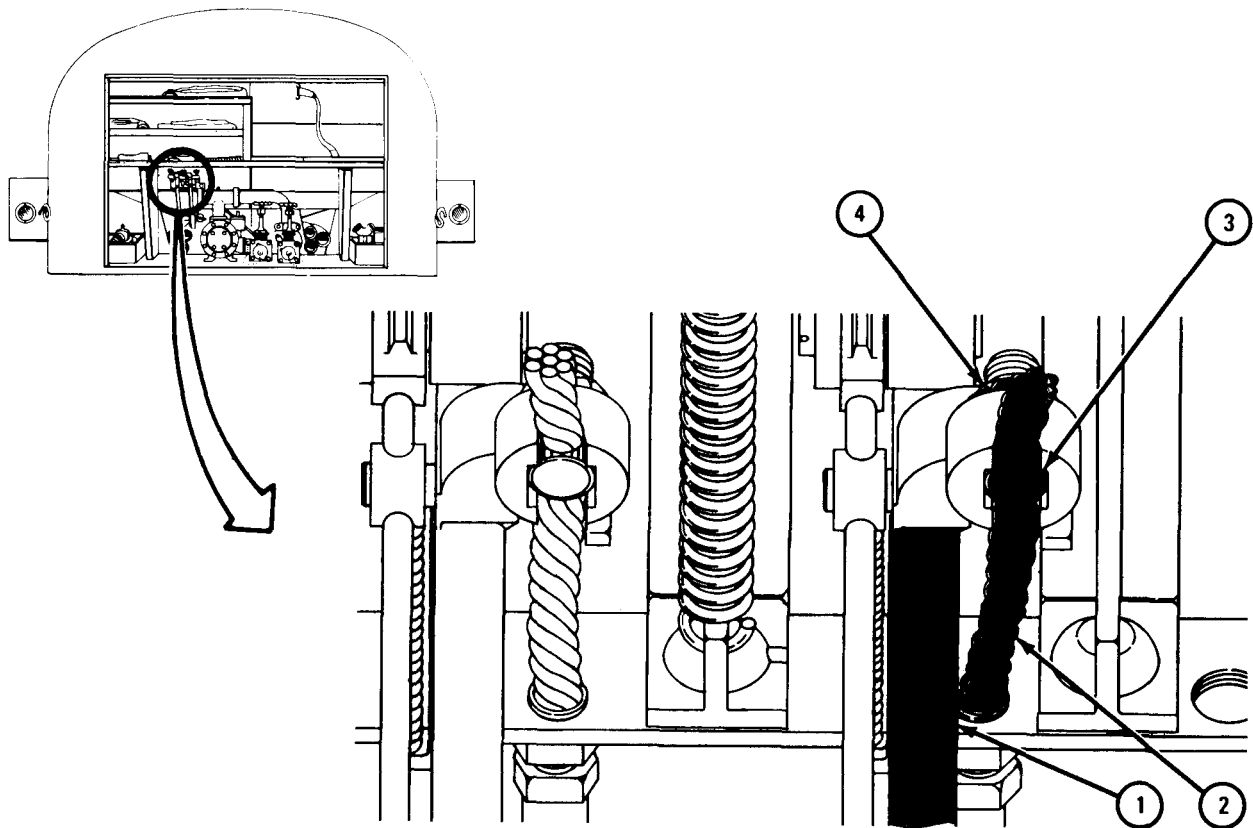

TA 083373

(2) Front discharge valve cable.

FRAME 1

1. Slide thimble (1) on end of cable (2).
2. Working under rear of tank, put end of cable (2) around eye (3) in discharge valve lever (4) and back through thimble (1) as shown.
3. Put split nut (5) over cable (2) between thimble (1) and eye (3).
4. Using pliers, hold split nut (5) together. Screw on thimble (1).
5. Using 13/16-inch and 7/8-inch wrenches, hold split nut (5) and tighten thimble (1).

GO TO FRAME 2

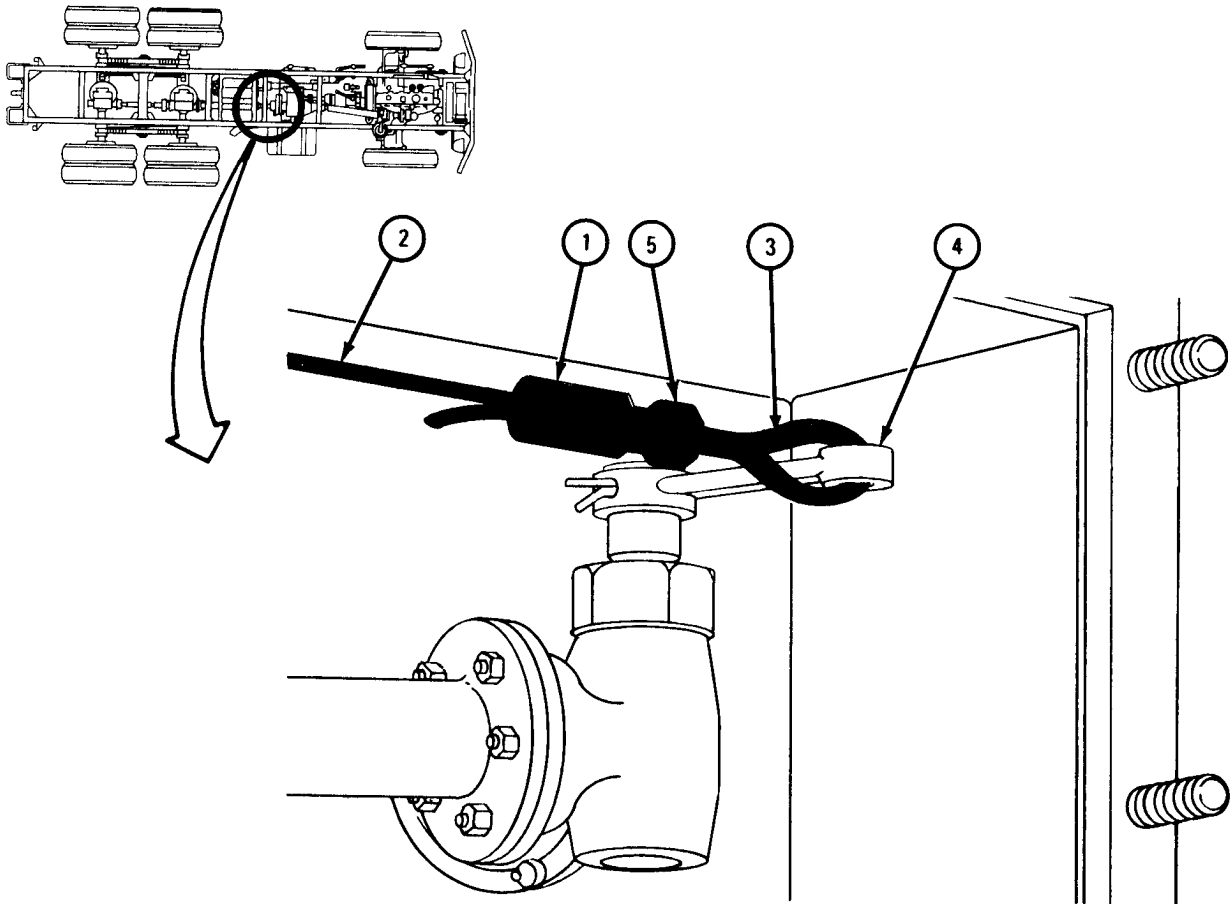

TA 083371

FRAME 2

1. Working under rear of tank, pull end of cable (1) over frame (2) and through hole in wall (3), and push all slack in cable through hole.

GO TO FRAME 3

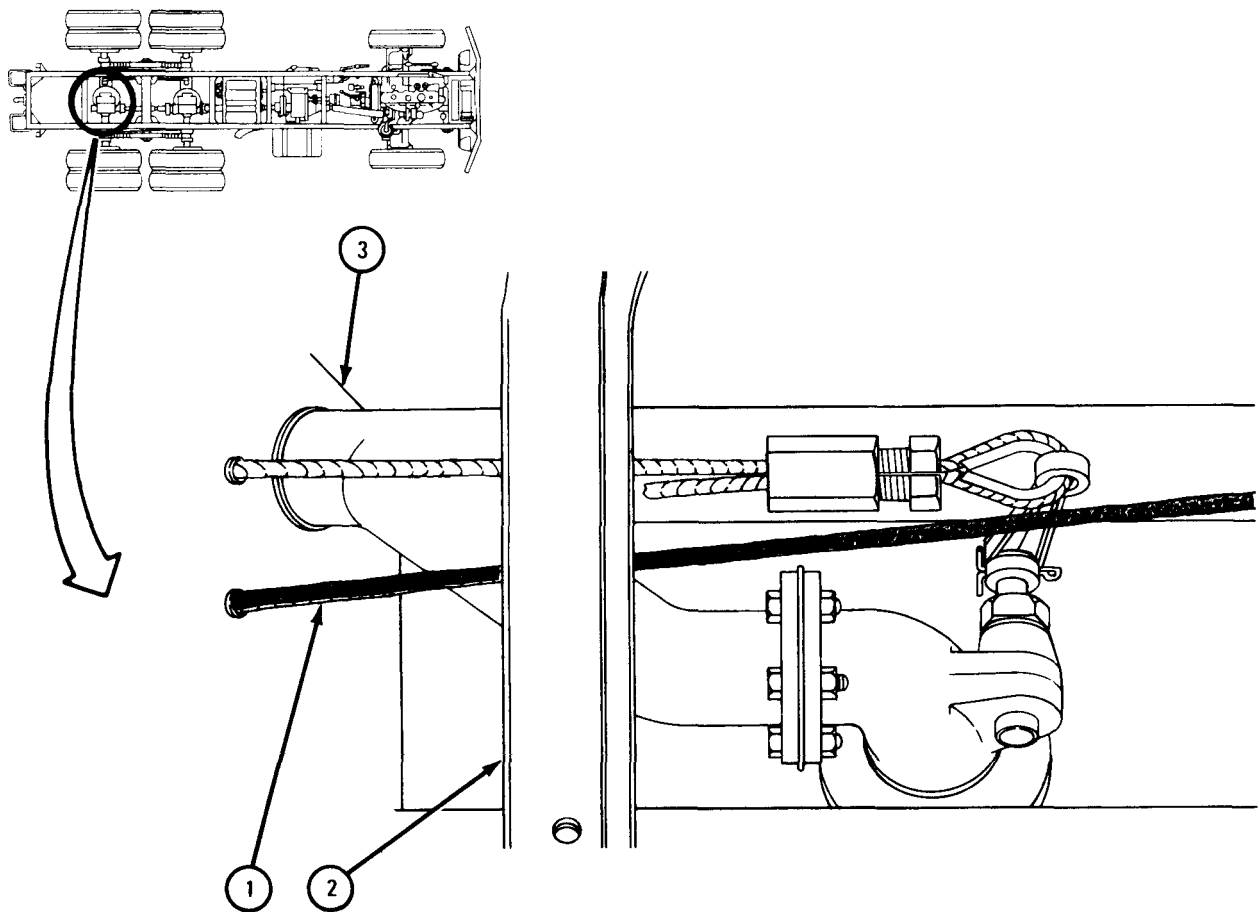

TA 083391

FRAME 3

1. Put front discharge lever (1) in forward (off) position.
2. Using pliers, pull cable (2) through hole in bolt (3) until all slack is out of cable.

CAUTION

Do not put any tension on cable (2) when tightening nut (4).

3. Using 1/2-inch wrench, tighten nut (4).

NOTE

Follow-on Maintenance Action Required:

1. Lubricate tubes. Refer to LO 9-2320-209-12/1.
2. Refer to discharge valve replacement, para 18-53, for replacement of bottom cover plate under tank section of chassis.

END OF TASK

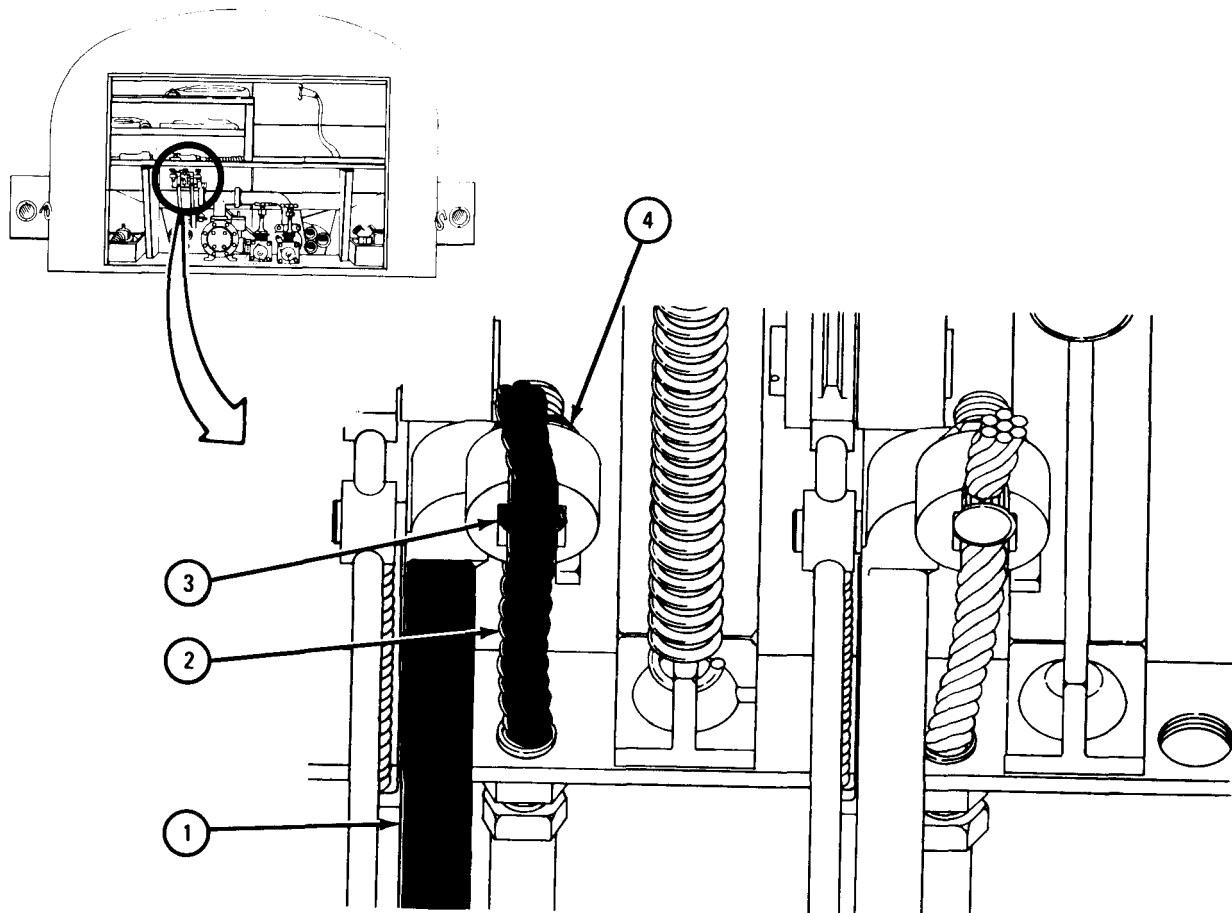

TA 083392



## 18-57. DISCHARGE PIPE REMOVAL AND REPLACEMENT (TRUCKS M50A1, M50A2, AND M50A3).

TOOLS: Cross-tip screwdriver (Phillips type)  
9/16-inch open end wrench  
9/16-inch socket  
Universal joint  
10-inch extension  
5/8-inch open end wrench  
11/16-inch socket  
Ratchet  
11/16-inch open end wrench  
7/16-inch socket  
7/16-inch open end wrench  
7/8-inch open end wrench

SUPPLIES: Discharge valve gasket (2)

PERSONNEL: Two

EQUIPMENT CONDITION: Truck parked, engine off, handbrake set.

a. Preliminary Procedure. Drain all water from holding compartments. Refer to TM 9-2320-209-10.

b. Removal.

(1) Trucks M50A1 and M50A2.

FRAME 1

- Soldier A
1. Open pump compartment doors.
  2. Using 11/16-inch wrench, unscrew and take off two nuts (1).
  3. Take out two bolts (2).
  4. Take off two halves of coupling clamp (3).
  5. Slide coupling gasket (4) toward rear of truck.

GO TO FRAME 2

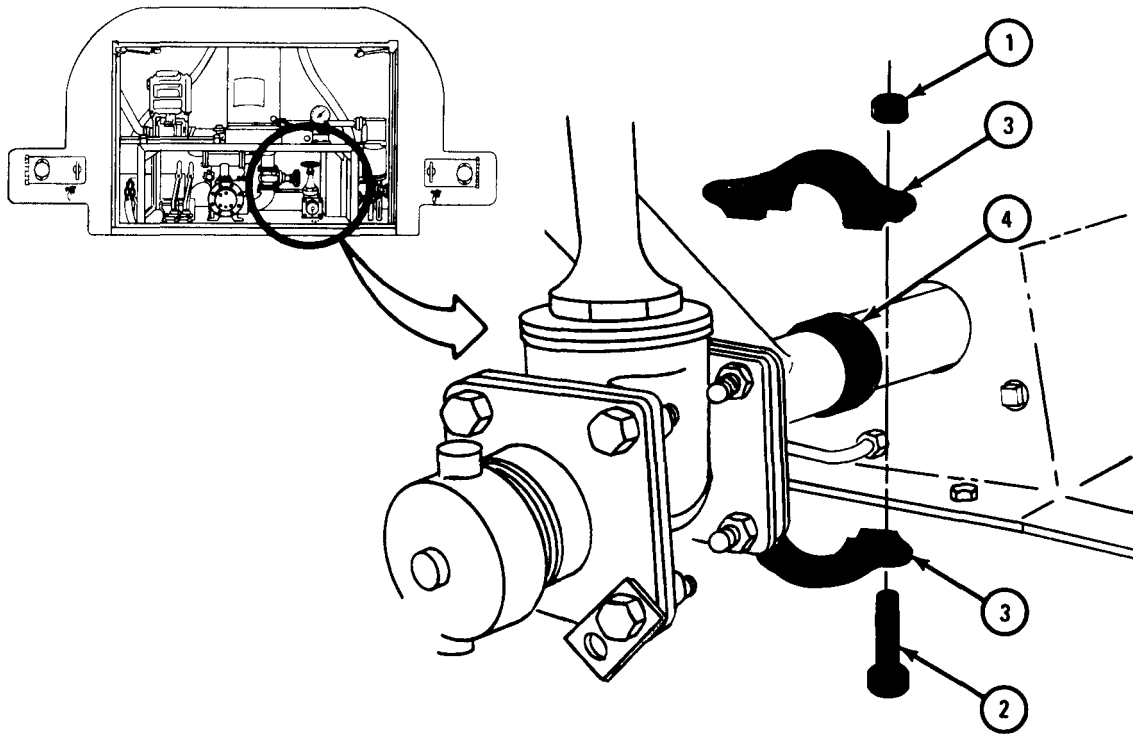

TA 104701

FRAME 2

Soldier A 1. Using 9/16-inch wrench, hold three capscrews (1).

Soldier B 2. Using 9/16-inch wrench, unscrew and take off three nuts (2) and washers (3).

Soldier A 3. Take out three capscrews (1).

GO TO FRAME 3

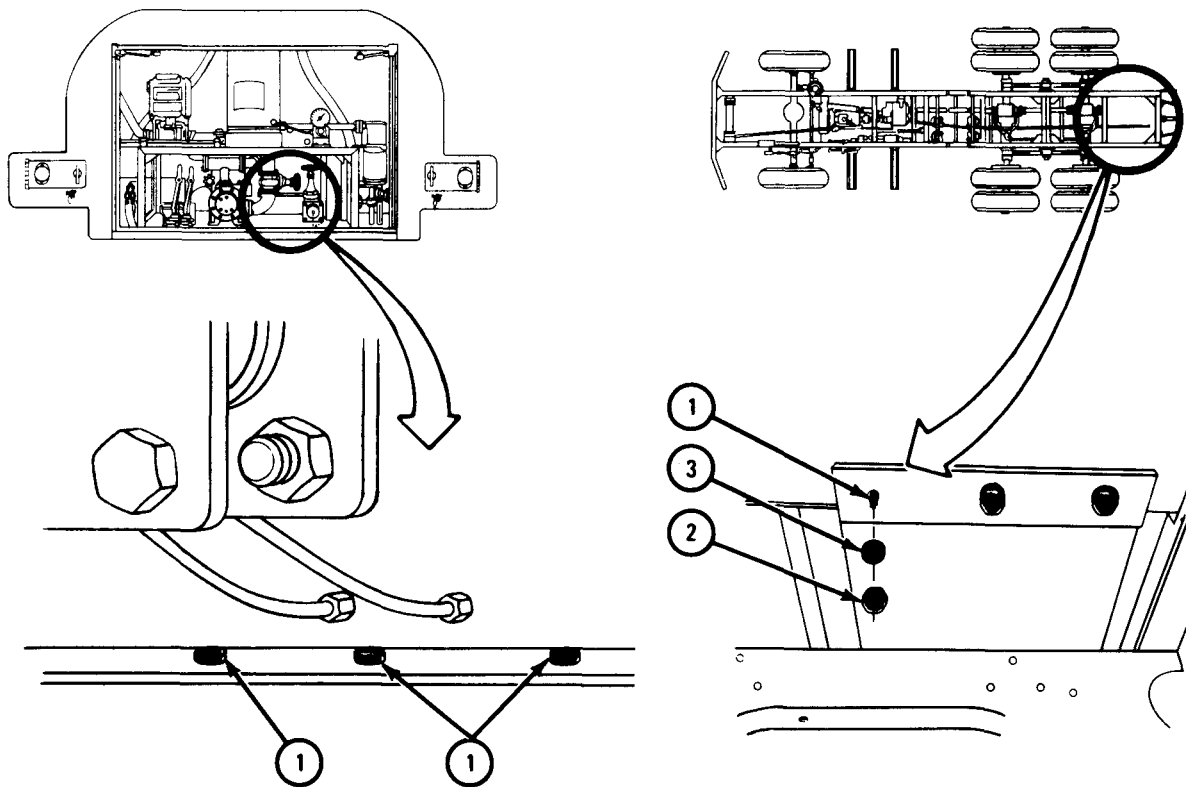

TA 104702

FRAME 3

- Soldier A 1. Using 9/16-inch wrench, hold three capscrews (1).
  - Soldier B 2. Using 9/16-inch socket and ratchet, unscrew and take off three nuts (2) and washers (3).
  - Soldier A 3. Take out three capscrews (1).
  - Soldier B 4. Using phillips screwdriver, unscrew and take out four screws (4).
  - Soldiers A and B 5. Slide cover (5) to left side of truck.
- GO TO FRAME 4

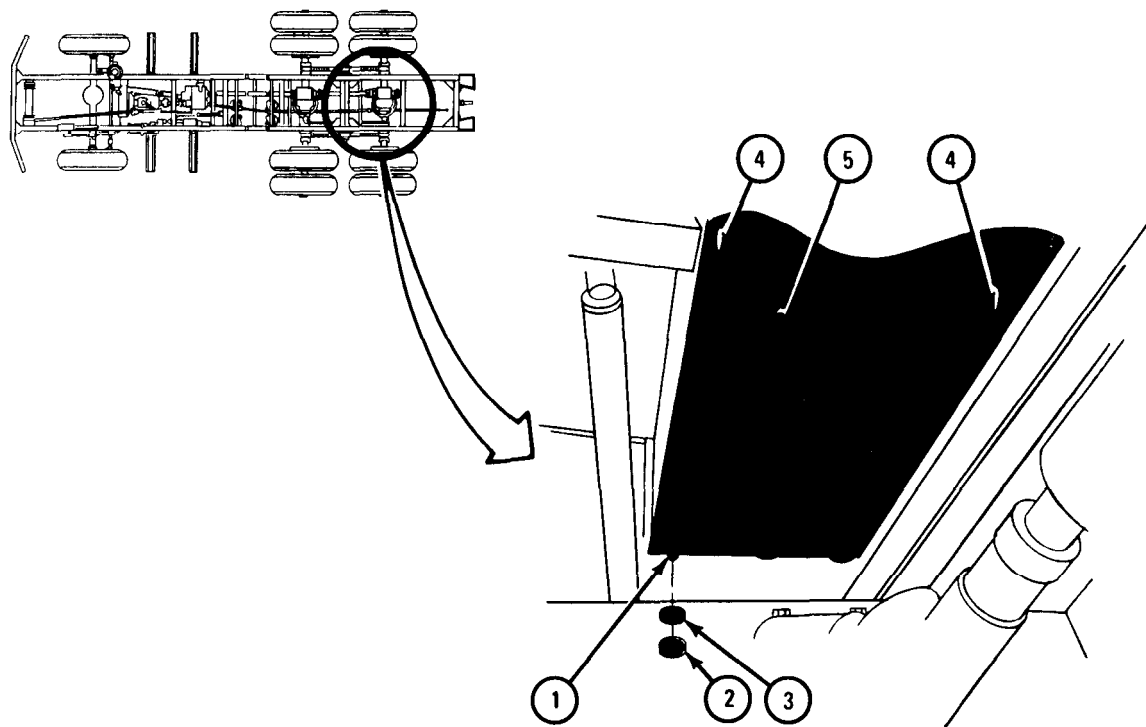

TA 104703

## FRAME 4

- Soldier A 1. Using 9/16-inch wrench, hold six capscrews (1).
- Soldier B 2. Using 9/16-inch socket, extension, universal joint, and ratchet, unscrew and take off six nuts (2) and washers (3).
- Soldier A 3. Take out six capscrews (1).
- Soldiers A and B 4. Take discharge pipe (4) away from discharge valve (5).
- Soldier A 5. Take out discharge valve gasket (6). Throw away discharge valve gasket.

GO TO FRAME 5

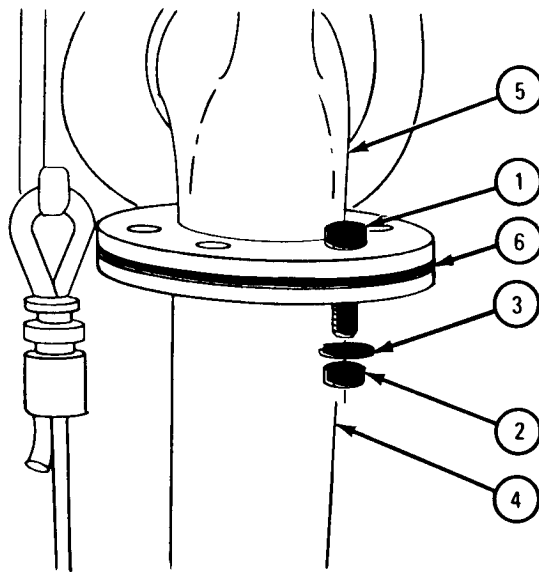

TA 104704

FRAME 5

- Soldier A 1. Using 9/16-inch wrench, hold six capscrews (1).
- Soldier B 2. Using 9/16-inch socket, extension, universal joint, and ratchet, unscrew and take off six nuts (2) and washers (3).
- Soldier A 3. Take out six capscrews (1).
- Soldiers A and B 4. Take discharge pipe (4) away from discharge valve (5).
- Soldier A 5. Take out and throw away discharge valve gasket (6).
- GO TO FRAME 6

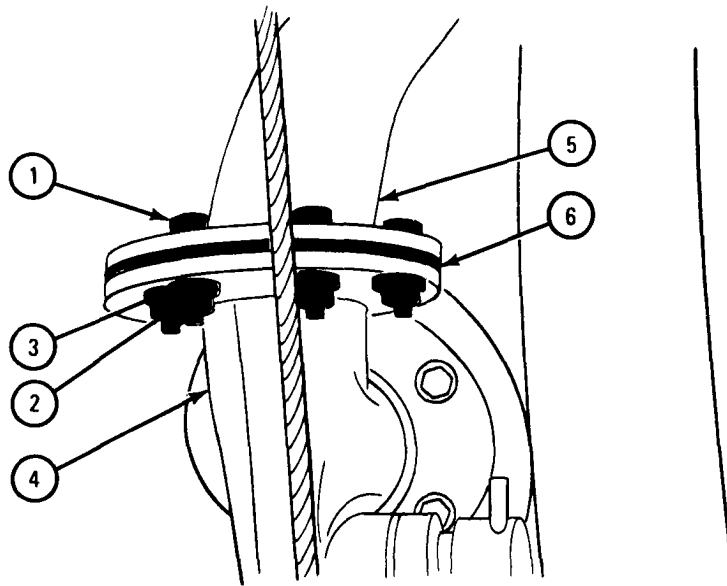

TA 104705

FRAME 6

Soldiers 1. Pull pipe (1) down and out toward front of truck.  
A and B

END OF TASK

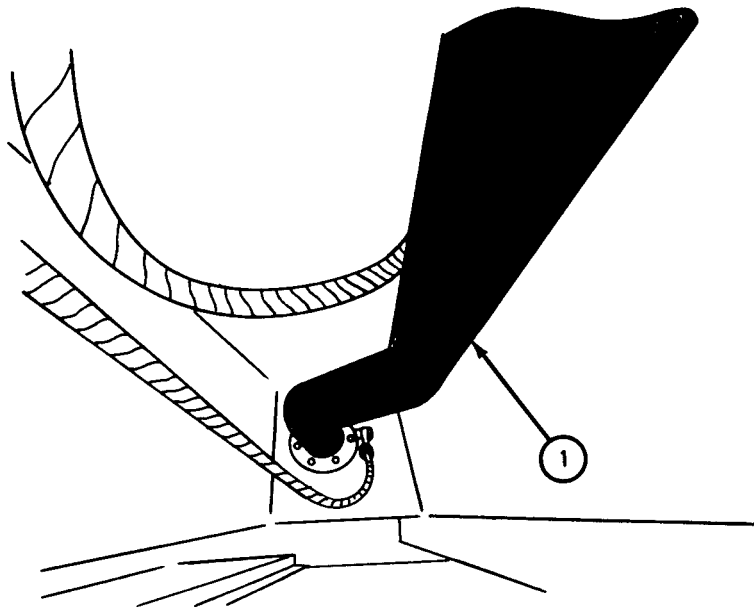

TA 104706

(2) Truck M50A3.

FRAME 1

Soldier A 1. Open pump compartment doors.

2. Using 7/8-inch wrench, unscrew and take off two nuts (1).

Soldier B 3. Take out two bolts (2).

4. Take off two halves of coupling clamp (3).

5. Slide coupling gasket (4) toward rear of truck.

GO TO FRAME 2

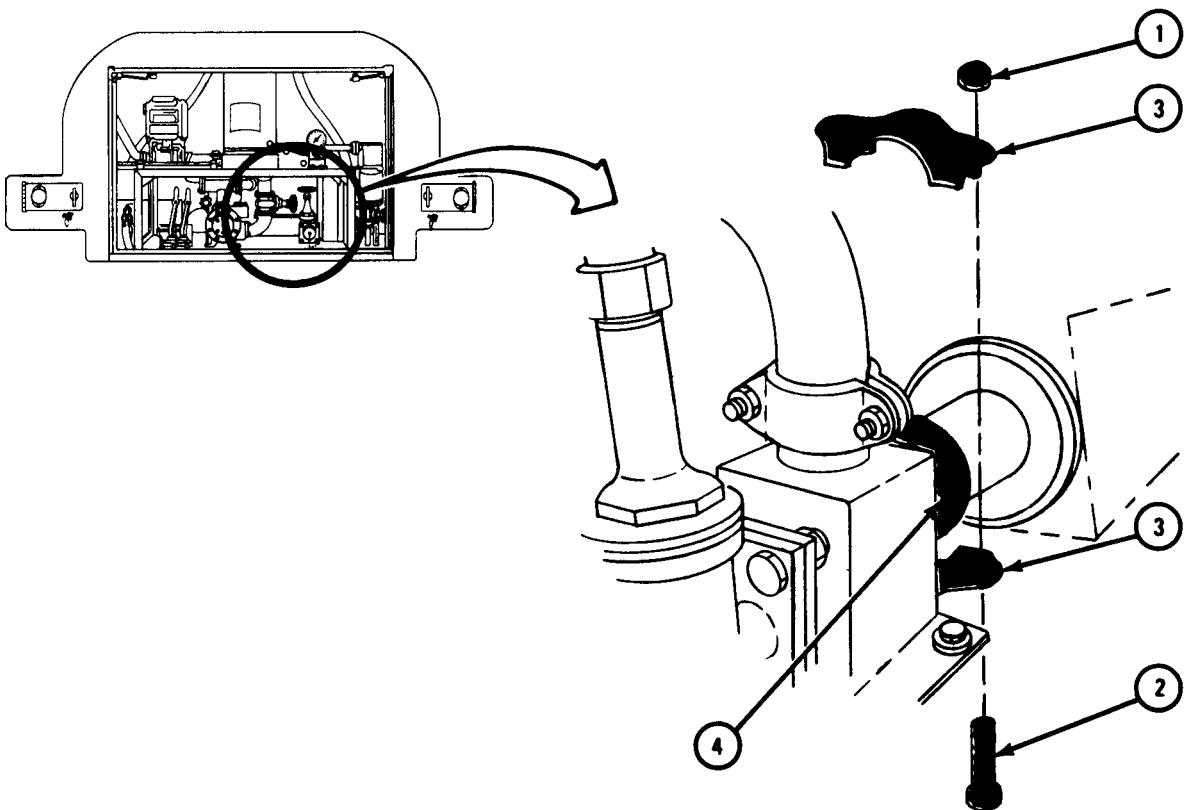

TA 104707



## FRAME 2

- Soldier A 1. Using 7/16-inch wrench, hold four capscrews (1).
- Soldier B 2. Working under rear of truck using 7/16-inch socket, universal, extension, and ratchet, take off four nuts (2).
- Soldier A 3. Take out four capscrews (1).
4. Slide off two plates (3).

GO TO FRAME 3

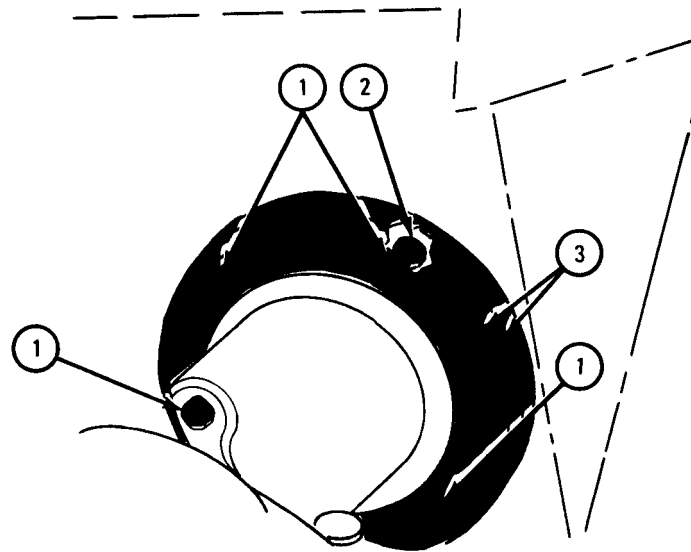

TA 104708

FRAME 3

Soldier A 1. Using phillips screwdriver, take out 52 screws (1).

Soldiers 2. Slide cover plate (2) to left side of truck.  
A and B

GO TO FRAME 4

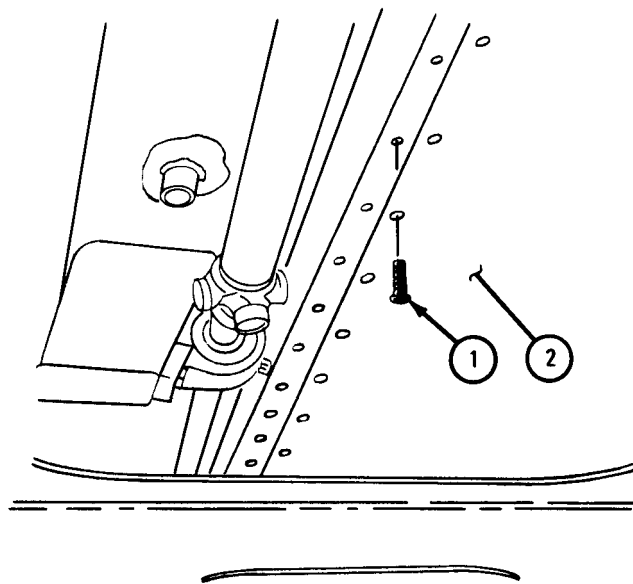

TA 104709

## FRAME 4

- Soldier A 1. Using 9/16-inch wrench, hold two screws (1).
- Soldier B 2. Using 7/8-inch wrench, unscrew and take off two nuts (2).
- Soldier A 3. Take out two screws (1).
4. Take off two halves of coupling clamp (3).
- Soldier B 5. Slide coupling gasket (4) toward front of truck.
- GO TO FRAME 5

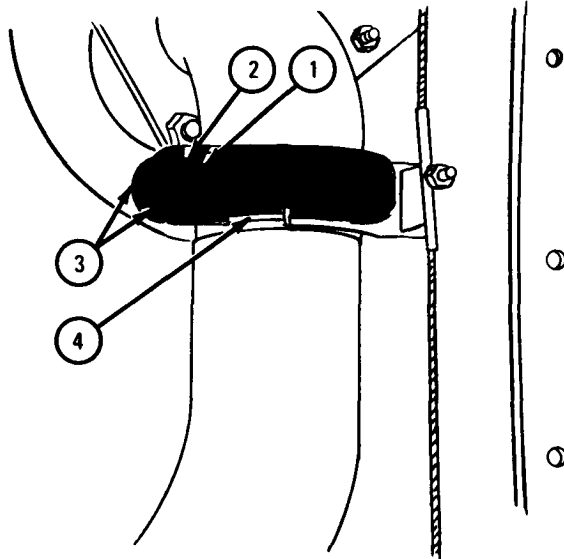

TA 104710

FRAME 5

- Soldier A 1. Using 9/16-inch wrench, hold two bolts (1).
- Soldier B 2. Using 7/8-inch wrench, unscrew and take off two nuts (2).
- Soldier A 3. Take out two bolts (1).
4. Take off two halves of coupling clamp (3).
- Soldier B 5. Slide coupling gasket (4) towards front of truck.
- GO TO FRAME 6

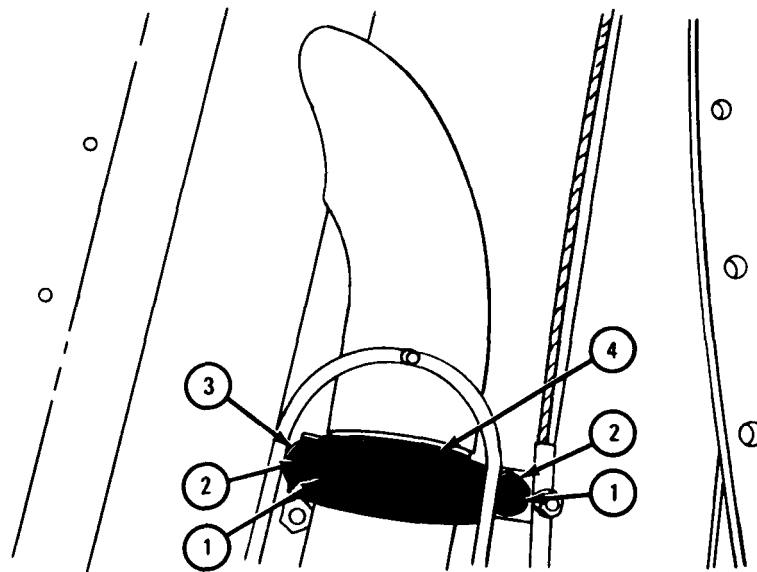

TA 104711

FRAME 6

Soldiers 1. Pull pipe (1) down and out toward front of truck.  
A and B

END OF TASK

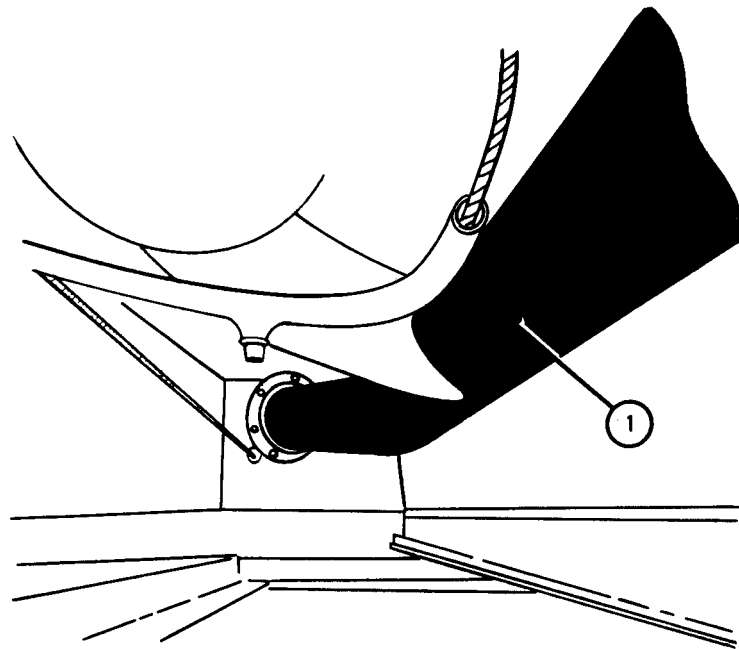

TA 104712

c. Replacement.

(1) Trucks M50A1 and M50A2.

FRAME 1

Soldiers 1. Put pipe (1) up into truck from front of truck.

A and B

GO TO FRAME 2

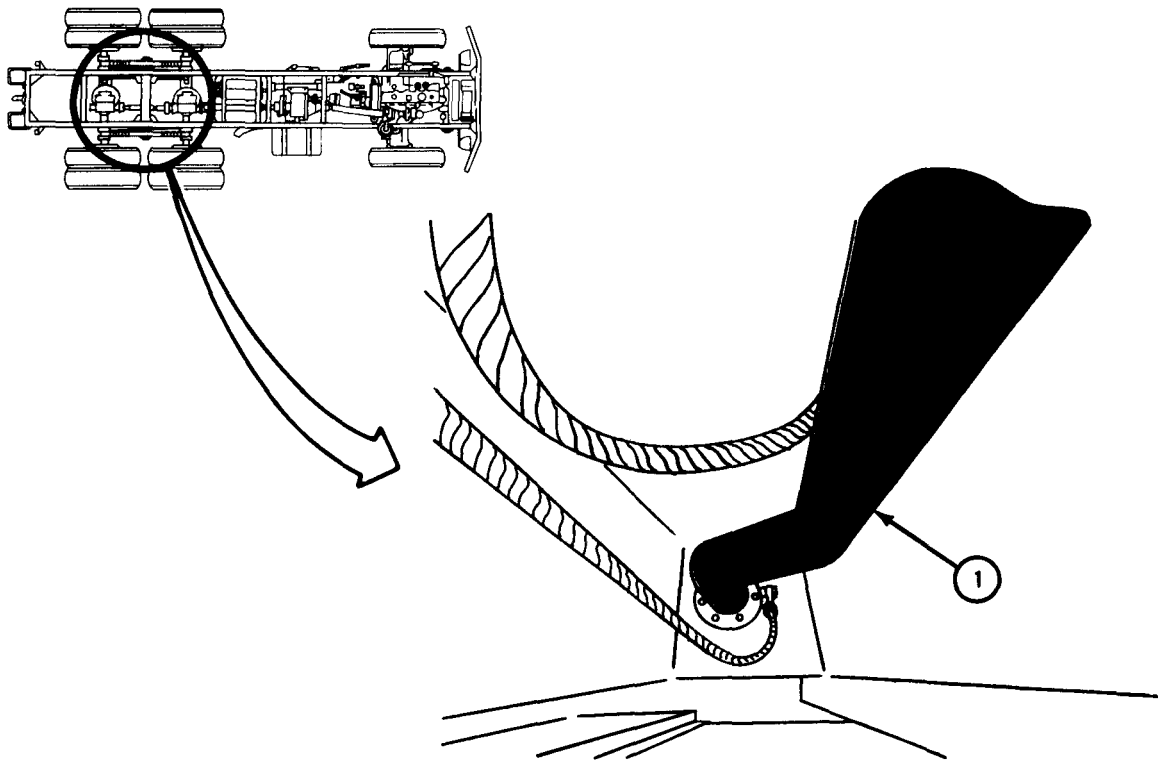

TA 104713

## FRAME 2

- Soldier A 1. Put discharge valve gasket (1) between discharge valve (2) and discharge pipe (3), alining holes.
- Soldier B 2. Put in six capscrews (4). Using 9/16-inch wrench, hold capscrews.
- Soldier A 3. Put on six washers (5). Using 9/16-inch socket, extension, universal joint, and ratchet, screw on and tighten six nuts (6).
- GO TO FRAME 3

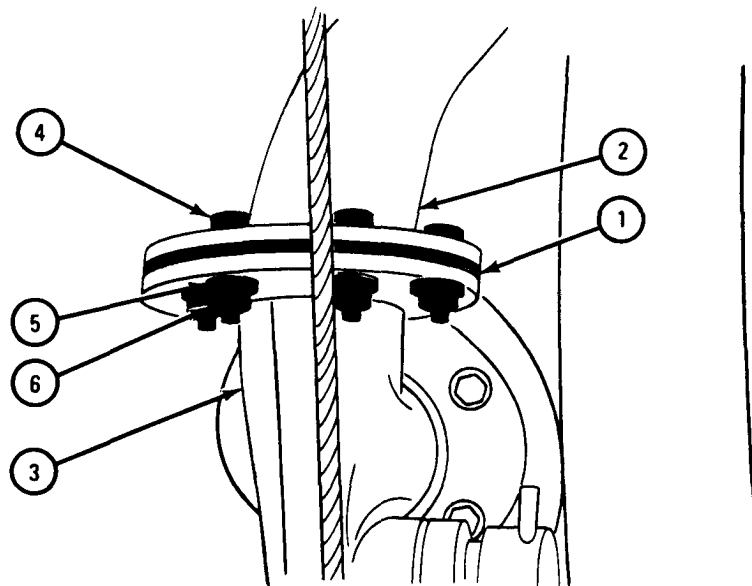

TA 104714

FRAME 3

- Soldier A 1. Put discharge valve gasket (1) between discharge valve (2) and discharge pipe (3), alining holes.
- Soldier B 2. Put in six cap screws (4). Using 9/16-inch wrench, hold capscrews.
- Soldier A 3. Put on six washers (5). Using 9/16-inch socket, extension, universal joint, and ratchet, screw on and tighten six nuts (6).

GO TO FRAME 4

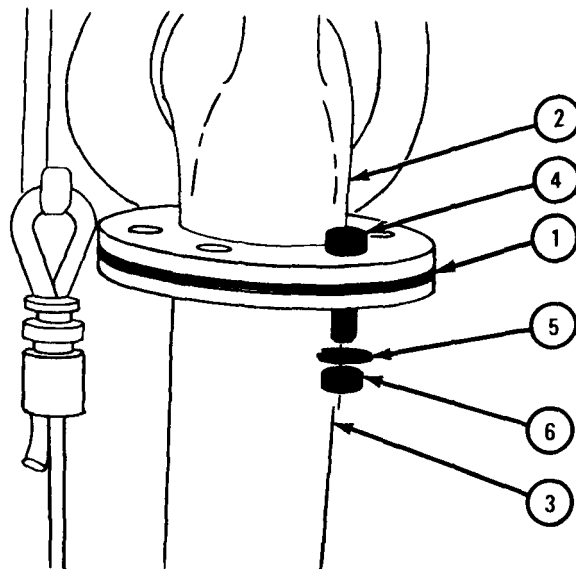

TA 104715



## FRAME 4

- Soldiers A and B 1. Slide cover (1) to right of truck until holes align.
- Soldier A 2. Hold up cover (1).
- Soldier B 3. Using phillips screwdriver, screw in and tighten four screws (2).
4. Put in three capscrews (3). Using 9/16-inch wrench, hold capscrews.
- Soldier A 5. Using 9/16-inch socket and ratchet, put on three washers (4) and screw on and tighten three nuts (5).

GO TO FRAME 5

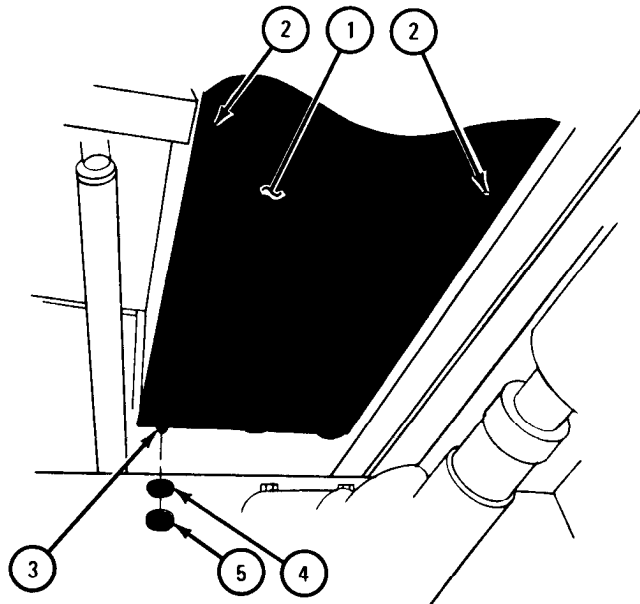

TA 104716

FRAME 5

Soldier A 1. Put in three capscrews (1). Using 9/16-inch wrench, hold capscrews.

Soldier B 2. Using 9/16-inch socket and ratchet, put on three washers (2) and put on and tighten three nuts (3).

GO TO FRAME 6

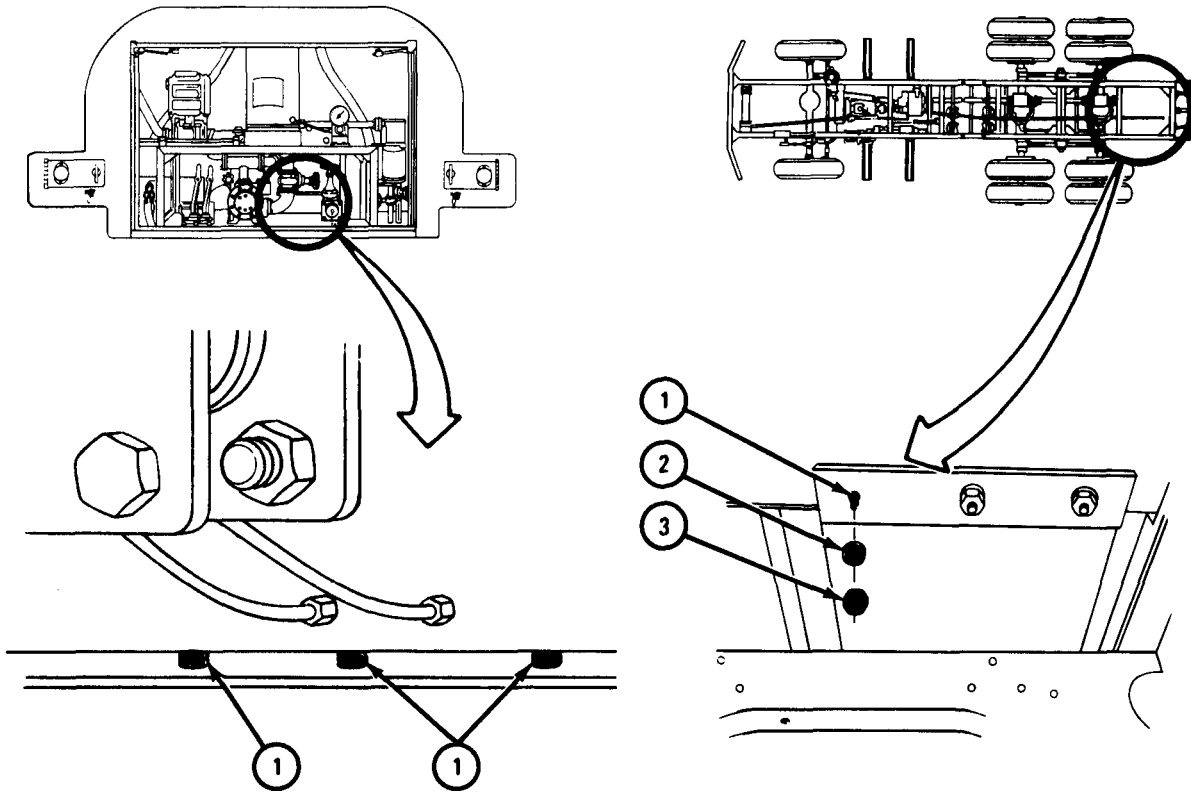

TA 104717

## FRAME 6

- Soldier A 1. Slide coupling gasket (1) toward front of truck.  
2. Put on two halves of coupling clamp (2).
- Soldier B 3. Put in two bolts (3).  
4. Using 11/16-inch socket and ratchet, screw on and tighten two nuts (4).
- Soldier A 5. Close pump compartment doors.  
END OF TASK

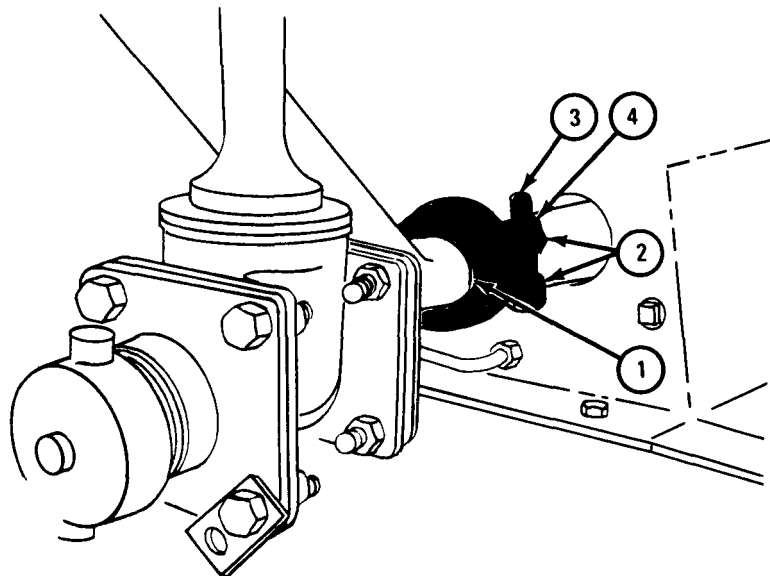

TA 104718

(2) Truck M50A3.

FRAME 1

Soldiers 1. Put discharge pipe (1) up into truck from front of truck.  
A and B

GO TO FRAME 2

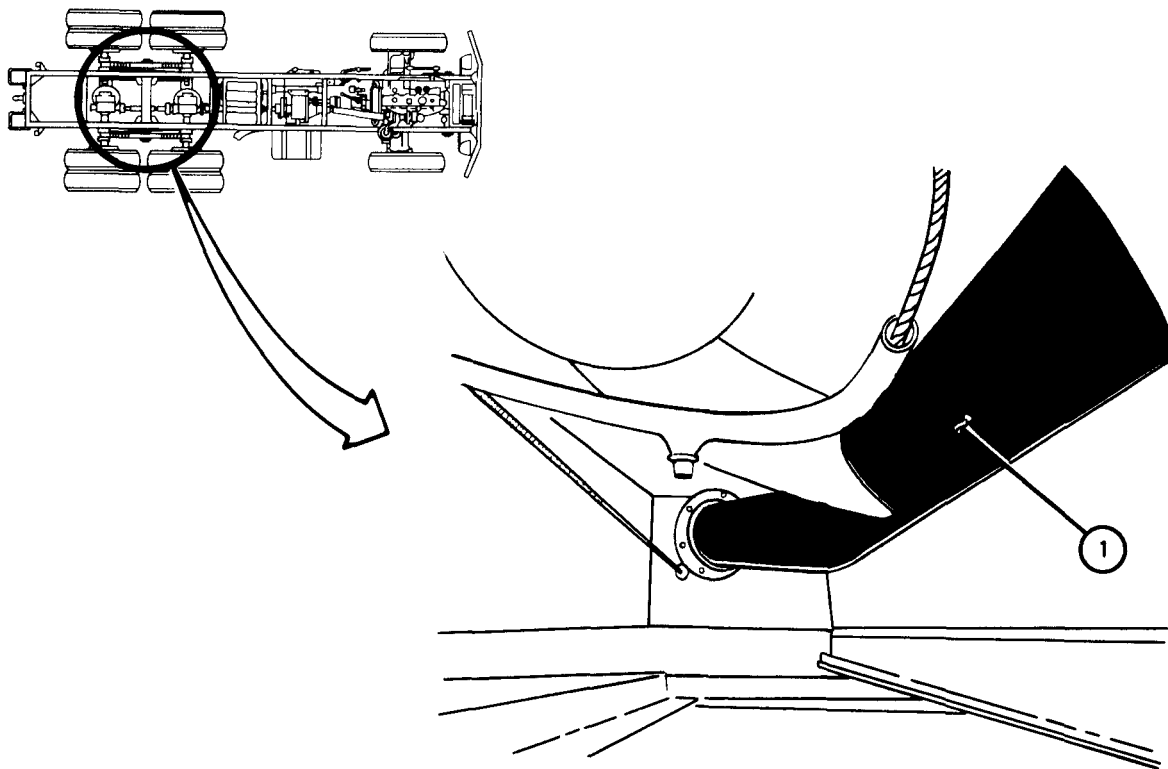

TA 104719

## FRAME 2

- Soldier A 1. Slide coupling gasket (1) towards rear of truck.
- Soldier B 2. Put on two halves of coupling clamp (2).
- Soldier A 3. Put in two bolts (3).
4. Using 9/16-inch wrench, socket, and ratchet, screw on and tighten two nuts (4).

GO TO FRAME 3

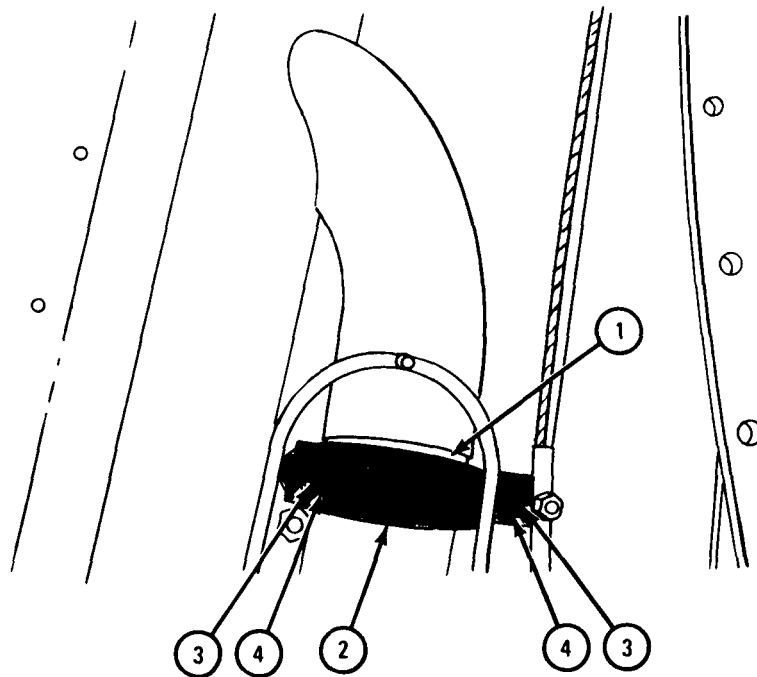

TA 104720

FRAME 3

- Soldier A 1. Slide coupling gasket (1) toward rear of truck.
- Soldier B 2. Put on two halves of coupling clamp (2).
- Soldier A 3. Put in two screws (3).
4. Using 7/8-inch wrench, socket, and ratchet, screw on and tighten two nuts (4).

GO TO FRAME 4

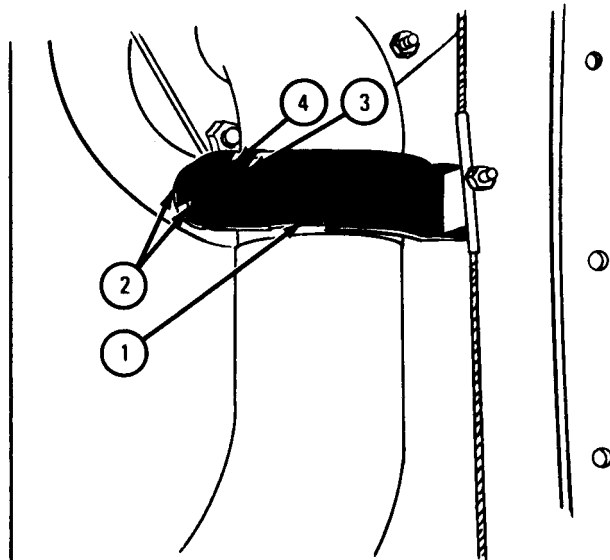

TA 104721

## FRAME 4

Soldiers 1. Slide cover (1) to right of truck until holes aline.  
A and B

Soldier A 2. Hold up cover (1).

Soldier B 3. Using phillips screwdriver, screw in and tighten 52 screws (2).

GO TO FRAME 5

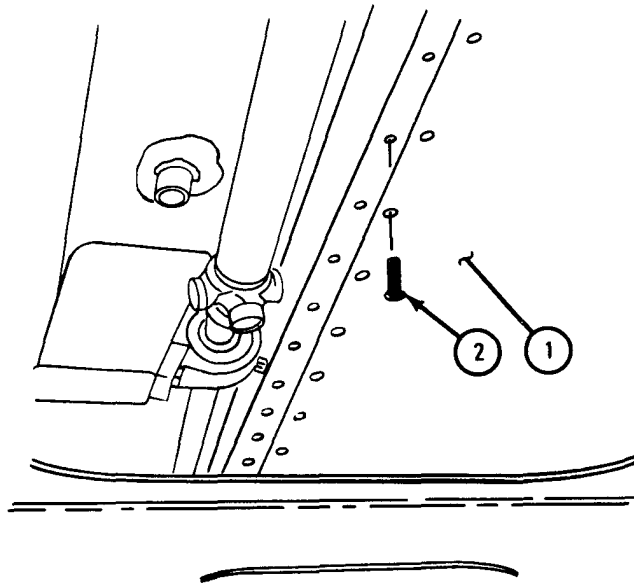

TA 104722

FRAME 5

- Soldier A
1. Aline holes in two plates (1) with holes in truck body.
  2. Put in four capscrews (2).
  3. Using 7/16-inch wrench, hold four capscrews (2).

- Soldier B
4. Working under rear of truck using 9/16-inch socket, universal, extension, and ratchet, screw on and tighten four nuts (3).

GO TO FRAME 6

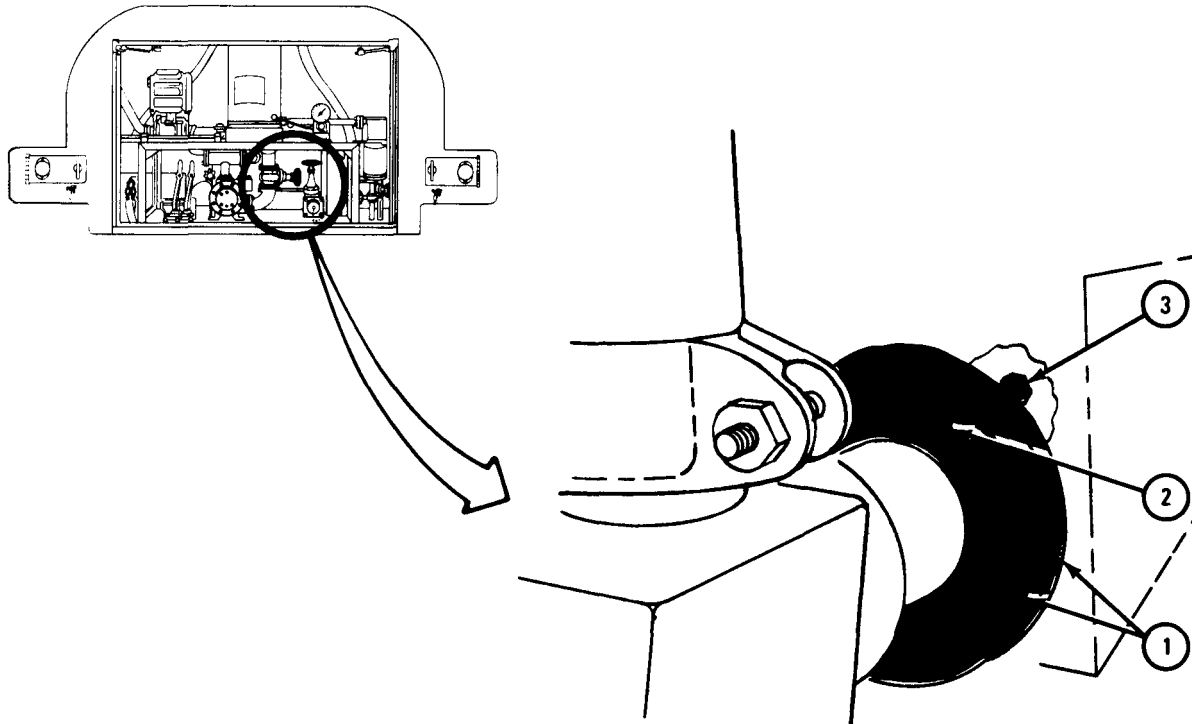

TA104723



## FRAME 6

- Soldier A 1. Slide coupling gasket (1) toward front of truck.
- Soldier B 2. Put on two halves of coupling clamp (2). Hold coupling clamp in place.
- Soldier A 3. Put in two bolts (3).
4. Using 5/8-inch wrench, screw on and tighten two nuts (4).
- Soldiers A and B 5. Close pump compartment doors.
- END OF TASK

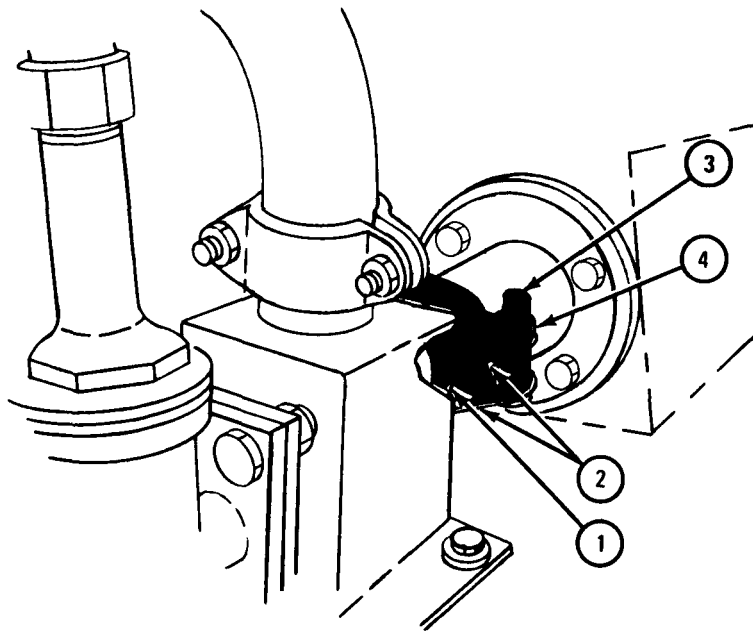

TA 104724

18-58. DELIVERY PUMP REMOVAL AND REPLACEMENT (TRUCKS M50A1, M50A2, AND M50A3).

TOOLS: 3/4-inch wrench  
          9/16-inch wrench  
          Nose pliers  
          9/16-inch socket  
          10-inch extension (socket set)  
          Ratchet

SUPPLIES: Delivery pump inlet gasket  
          Delivery pump outlet gasket

PERSONNEL: One

EQUIPMENT CONDITION: Truck parked, engine off, handbrake set.

a. Removal.

FRAME 1

1. Open rear compartment doors (1).
2. Using pliers, take off connecting link clip (2).
3. Take off link retainer (3), link (4), and sprocket chain (5).

GO TO FRAME 2

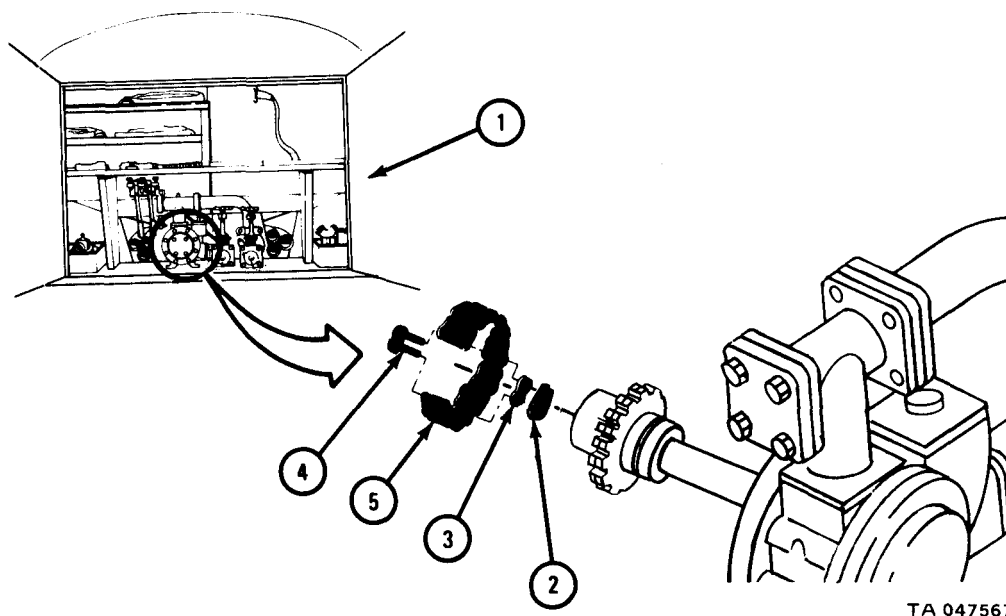

TA 047567

## FRAME 2

1. Using 9/16-inch wrench, unscrew and take out four screws (1) with lockwashers (2).
2. Take off gasket (3) and throw it away.

GO TO FRAME 3

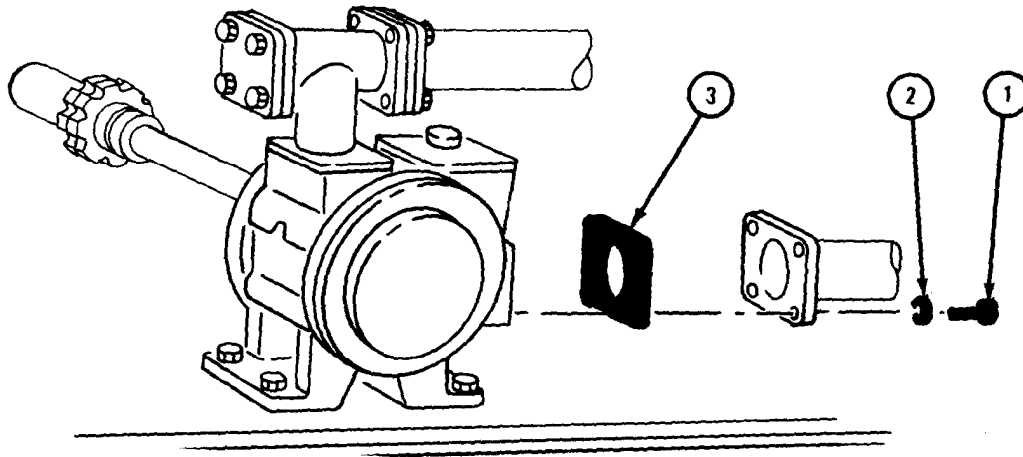

TA 047568

FRAME 3

1. Using 3/4-inch wrench, unscrew and take out four screws (1) with lockwashers (2).
2. Take off gasket (3) and throw it away.

GO TO FRAME 4

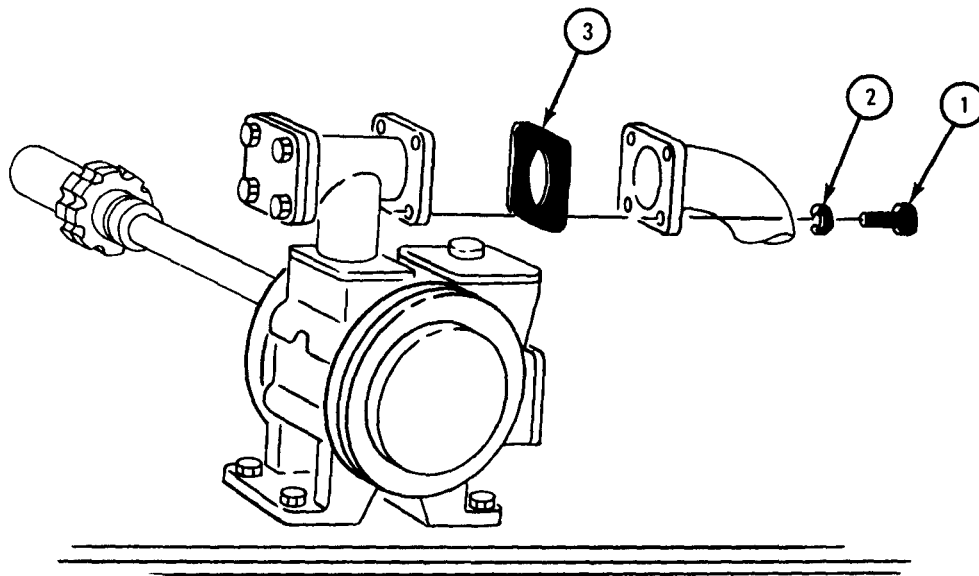

TA 047569

## FRAME 4

1. Using 9/16-inch wrenches, unscrew and take out four screws (1) and four nuts (2). Take out pump (3).

END OF TASK

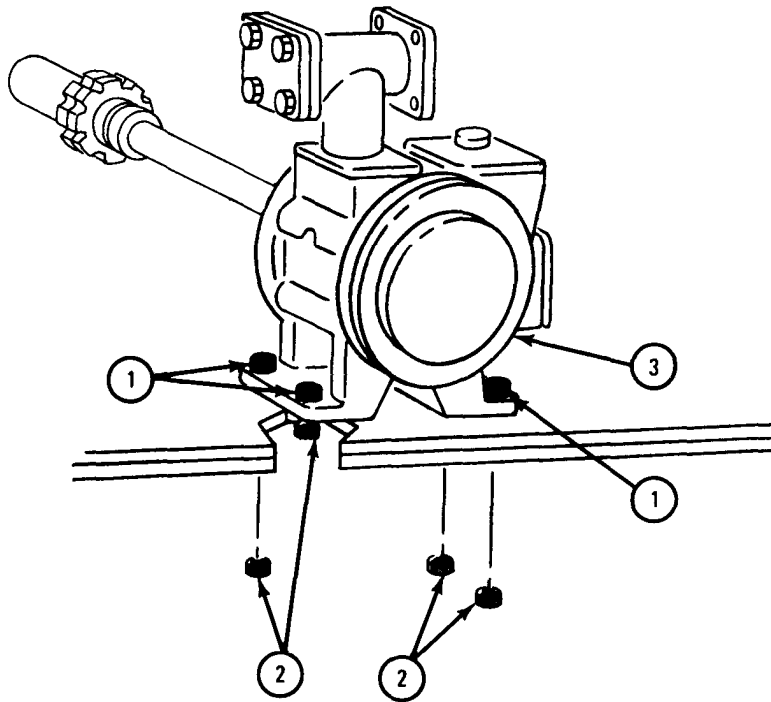

TA 047570

b. Replacement.

FRAME 1

1. Put pump (1) on shelf (2) and line up mounting holes in pump (1) and shelf (2).
2. Line up sprocket wheels (3 and 4).

GO TO FRAME 2

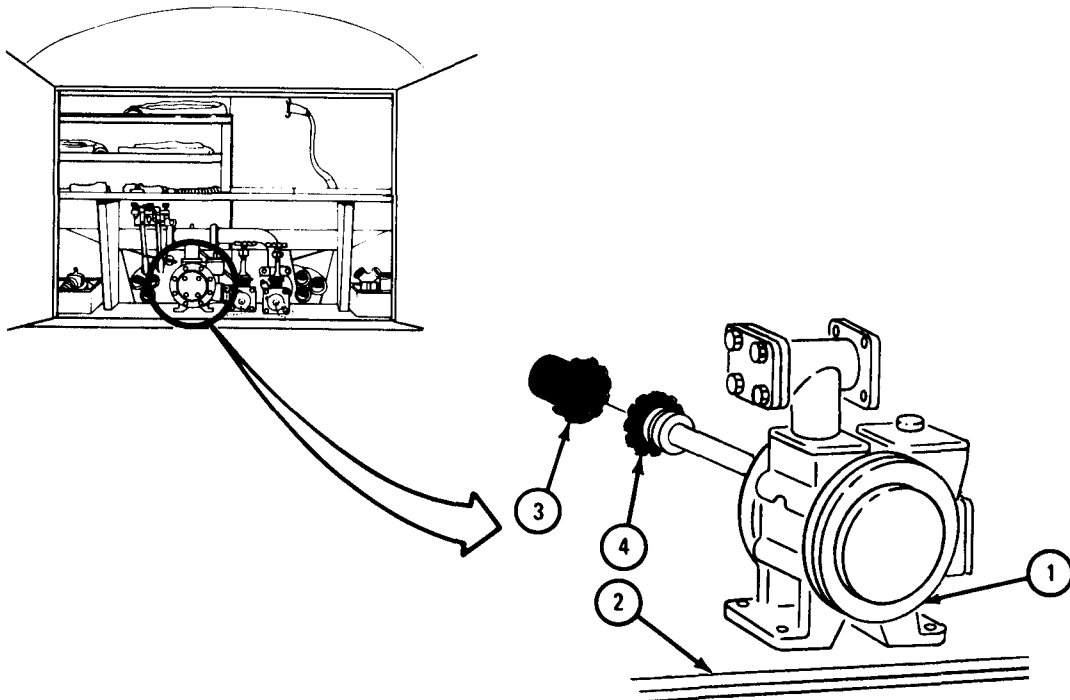

TA 047571

## FRAME 2

1. Put four screws (1) through mounting holes in pump (2) and shelf (3) and using 9/16-inch wrench, hold them.
2. Using 9/16-inch wrench, screw on four nuts (4). Do not tighten nuts all the way. Pump (2) must be free to slide.
3. Wrap sprocket chain (5) around both sprocket wheels (6).
4. Push connecting link (7) through holes in sprocket chain (5) and link retainer (8). Push on connecting link clip (9).

GO TO FRAME 3

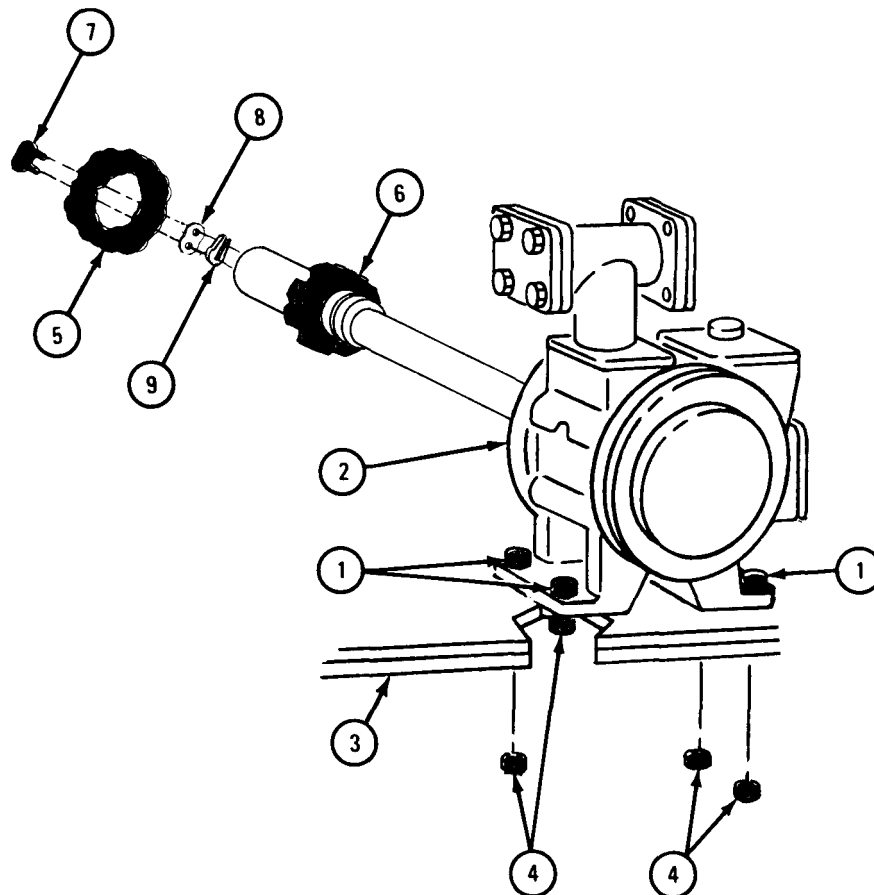

TA 047572

FRAME 3

1. Put gasket (1) between pump flange (2) and pipe flange (3), lining up holes.
2. Put lockwashers (4) on four screws (5) and using 3/4-inch wrench, screw in and tighten screws.

GO TO FRAME 4

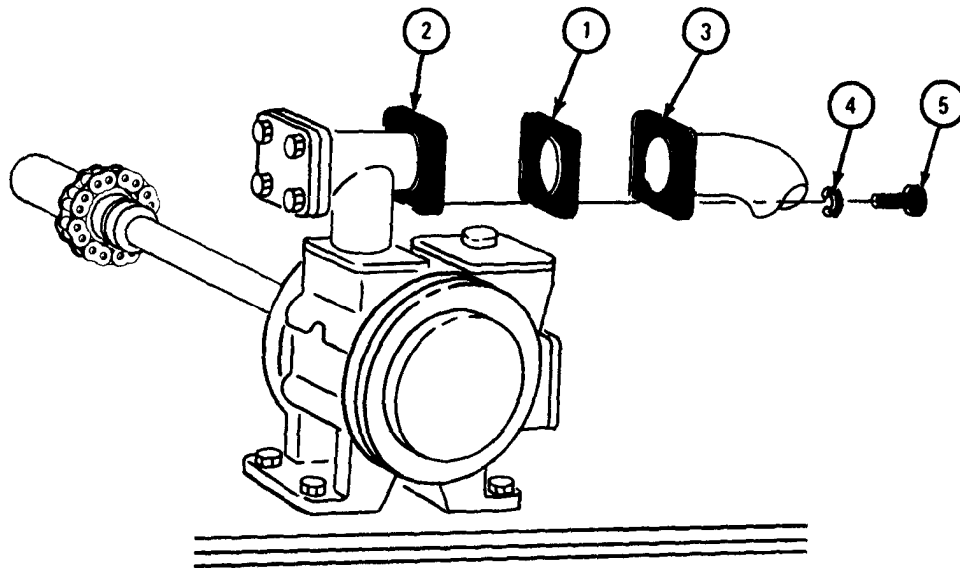

TA 047573



## FRAME 4

1. Put gasket (1) between pump flange (2) and pipe flange (3), lining up holes.
2. Put lockwashers (4) on four screws (5) and using 9/16-inch wrench, screw in and tighten screws.

GO TO FRAME 5

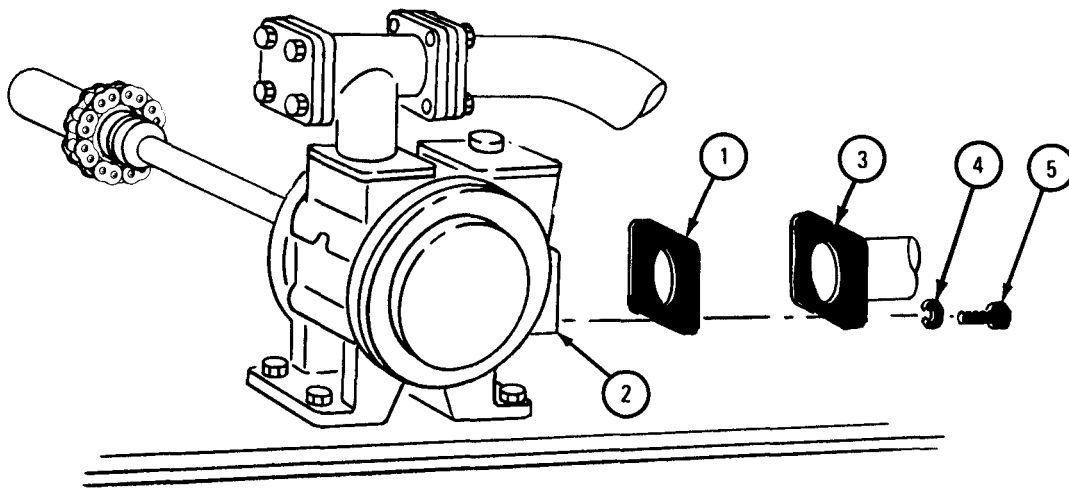

TA 047574

FRAME 5

1. Using 9/16-inch wrenches, hold four screws (1) and tighten four nuts (2).
2. Close rear compartment doors.

END OF TASK

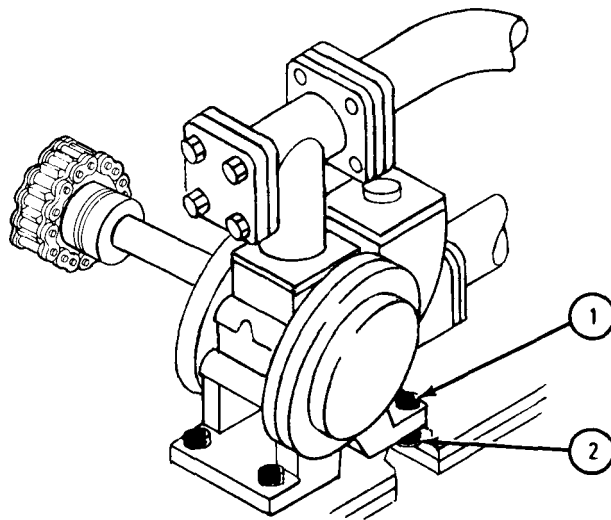

TA 047575

18-59. DELIVERY PUMP DRIVE SHAFT REMOVAL, REPAIR, AND REPLACEMENT.

- |        |   |  |
|--------|---|--|
| TOOLS: | 11/16-inch socket   | Brass punch  |
|        | 11/16-inch wrench (2)   | 5/16-inch wrench   |
|        | 1/8-inch sockethead screw key<br>(Allen wrench or equivalent) | 3/16-inch sockethead screw key<br>(Allen wrench or equivalent) |
|        | Pliers  | 9/16-inch wrench (2)   |
|        | 5/8-inch wrench   | Ratchet  |
|        | 8-ounce ballpeen hammer                                       | 2-inch extension   |
|        | Drift pin punch   |  |

SUPPLIES: None

PERSONNEL: Two

EQUIPMENT CONDITION: Truck parked, engine off, handbrake set.

a. Removal.

FRAME 1

1. Working under truck and using 3/16-inch allen wrench, loosen setscrew (1).
2. Using hammer, lightly tap drive shaft yoke (2) until shaft (3) is off.
3. Go to other end of drive shaft (3).

GO TO FRAME 2

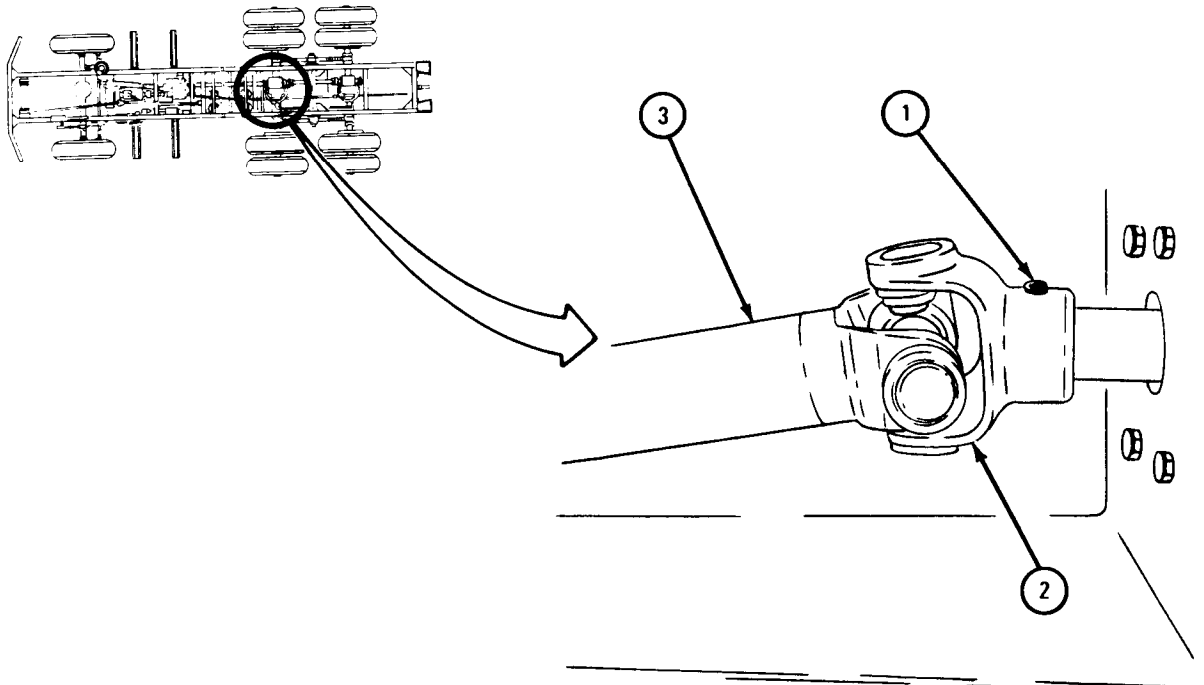

TA 047538

FRAME 2

1. Using 9/16-inch wrenches, unscrew and take off four nuts (1).
2. Hold drive shaft (2) so it does not fall. Take out four bolts (3).
3. Shorten shaft (2) by pushing on yoke (4) so spline (5) goes into shaft.

Soldiers A and B 4. Move yoke (4) clear of power takeoff flange (6). Pull shaft (2) forward to free other end and take it out from under truck.

GO TO FRAME 3

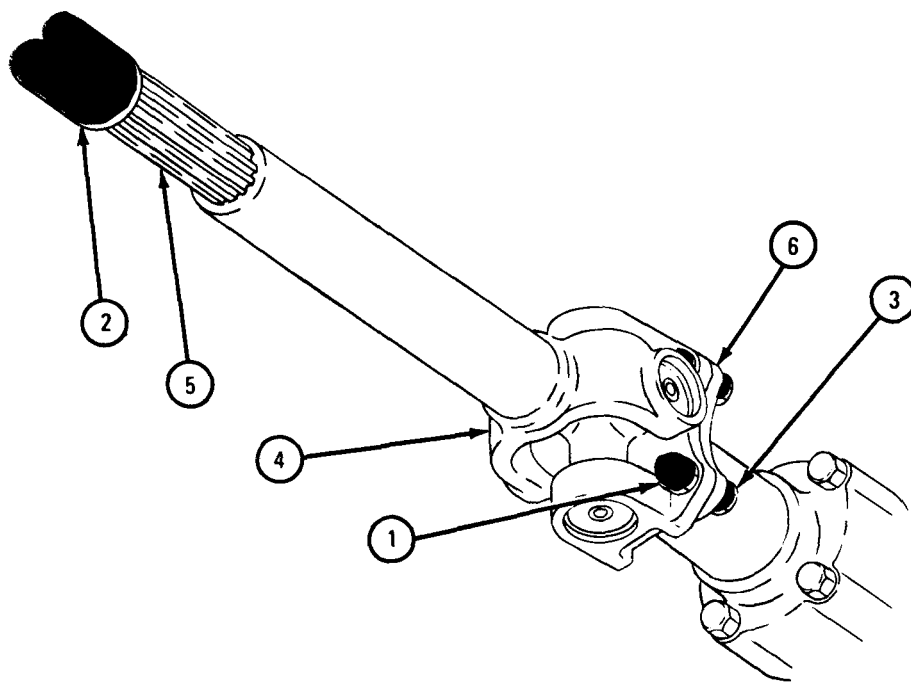

TA 047539

## FRAME 3

1. Using 11/16-inch and 5/8-inch wrenches, unscrew and take off four nuts (1).
2. Hold rear drive shaft (2) so it does not fall. Take out four screws (3).
3. Using 1/8-inch allen wrench, loosen two screws (4).
4. Wipe shaft (2) clean behind bearing unit (5) and slide bearing unit back on shaft about 1 foot.

GO TO FRAME 4

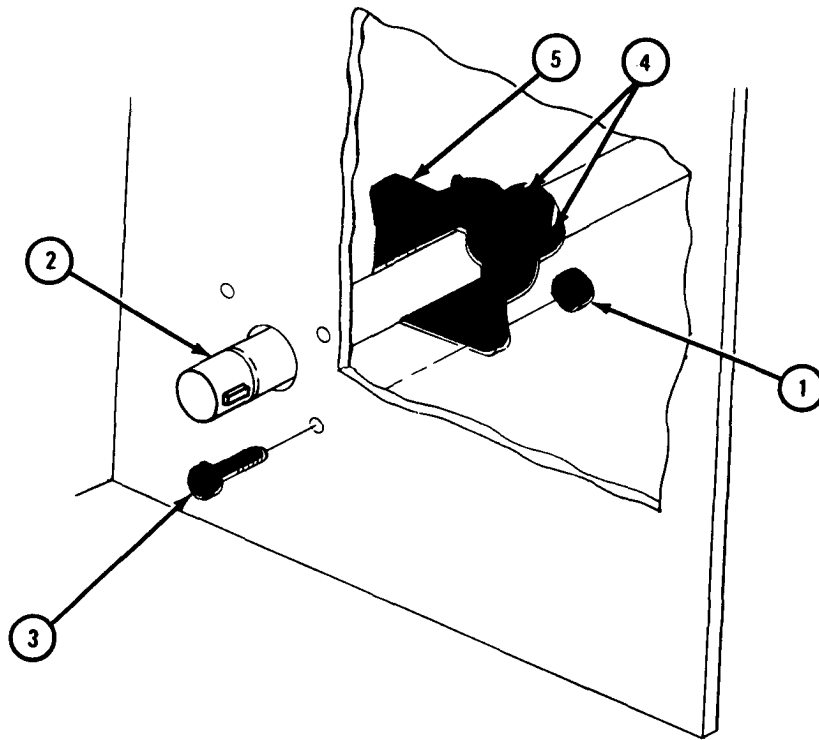

TA 047540

FRAME 4

1. Open rear compartment doors.
- Soldier A 2. Working in delivery compartment using 5/8-inch wrench, hold four screws (1) and tell soldier B when ready.
- Soldier B 3. Working under truck using 11/16-inch socket, ratchet, and extension, unscrew and take off four nuts (2).
- Soldier A 4. Using 1/8-inch allen wrench, loosen setscrew (3).
- Soldiers A and B 5. Working under truck, slide shaft (4) forward out of hole in rear bulkhead (5). Make sure two bearing units (6) do not slip off shaft.
6. Make rear end of shaft (4) down to clear rear bulkhead (5) and take shaft out from under truck.

GO TO FRAME 5

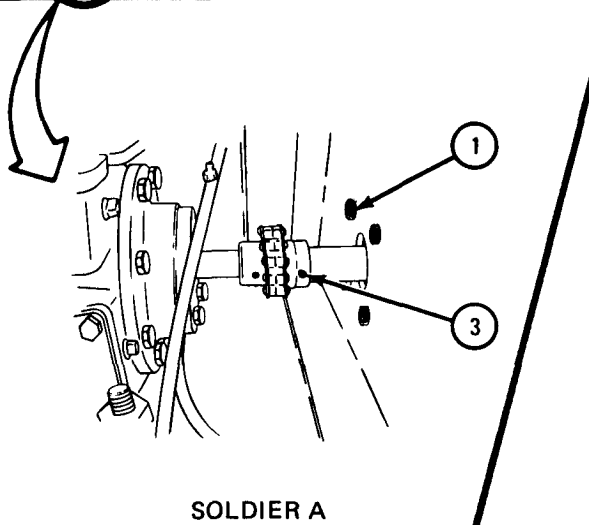
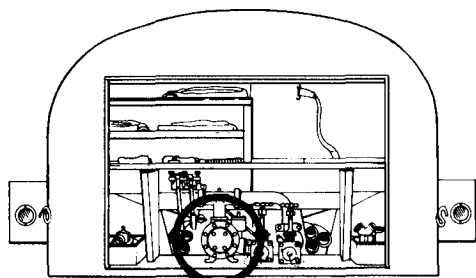

SOLDIER A

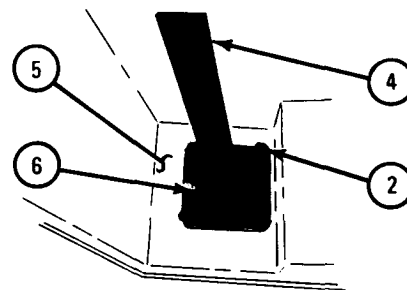

SOLDIER B

TA 047541

## FRAME 5

1. Using 1/8-inch allen wrench, loosen setscrew (1).
2. Using hammer and brass punch, tap off coupling (2).

END OF TASK

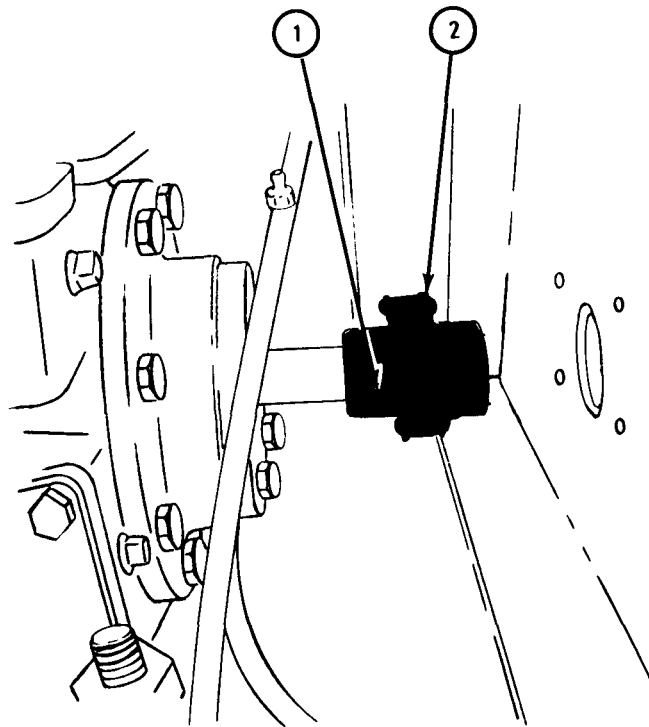

TA 047542

b. Repair.

(1) Front drive shaft. Repair of the front drive shaft is limited to replacement of universal joints. Refer to Part 1, para 10-5 to change snapping type joints.

(2) Rear driveshaft.

FRAME 1

1. Using pliers, pull off clip (1).
2. Take off connecting link (2).
3. Pull out link (3) and take off sprocket chain (4).
4. Using 1/8-inch allen wrench, unscrew and take out two setscrews (5).
5. Using hammer and punch, tap out two woodruff keys (6).
6. Using 1/8-inch allen wrench, loosen two screws (7).
7. Slide two bearing units (8) off ends of shaft (9).
8. Using 5/16-inch wrench, unscrew and take out two grease fittings (10).
9. Check that all parts are not worn or broken. If part is damaged, get a new one in its place.

GO TO FRAME 2

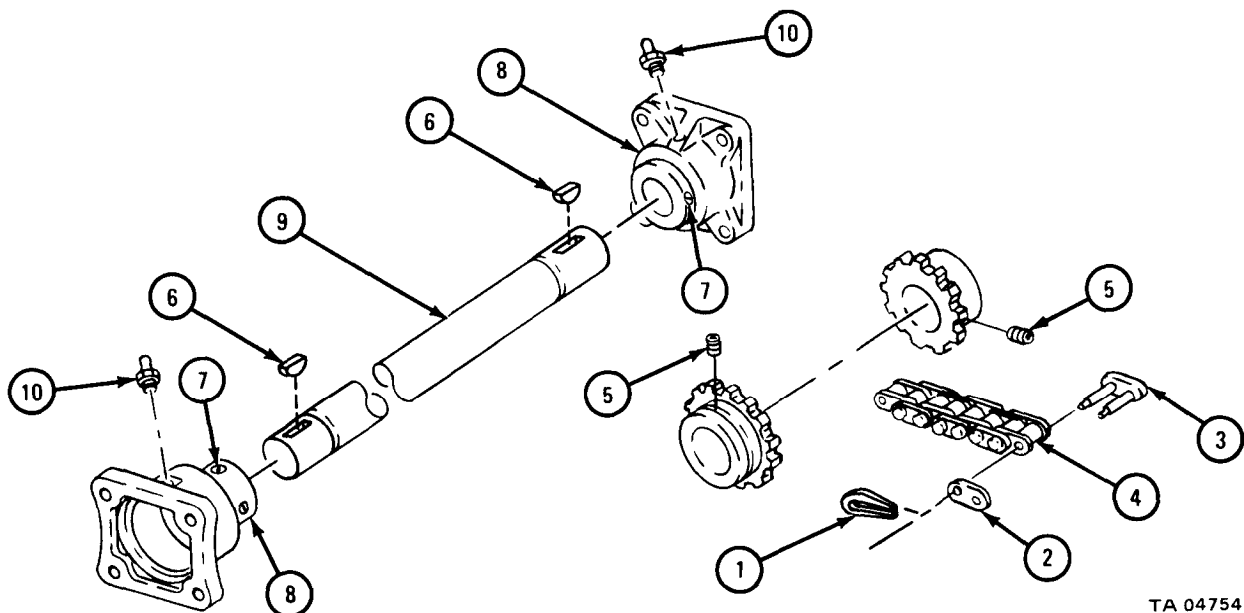

TA 047543



## FRAME 2

1. Using 5/6-inch wrench, screw in and tighten two grease fittings (1) into two bearing units (2).
2. Using 1/8-inch allen wrench, screw in two setscrews (3) partway into two sprockets (4).
3. Push two sprockets (4) together and wrap sprocket chain (5) around them.
4. Push pins on link (6) through holes on each end of sprocket chain (5).
5. Put on connecting link (7) and using pliers, push on clip (8).
6. Slide two bearing units (2) onto shaft (9).
7. Using hammer, tap in two woodruff keys (10) into grooves on shaft (9).

END OF TASK

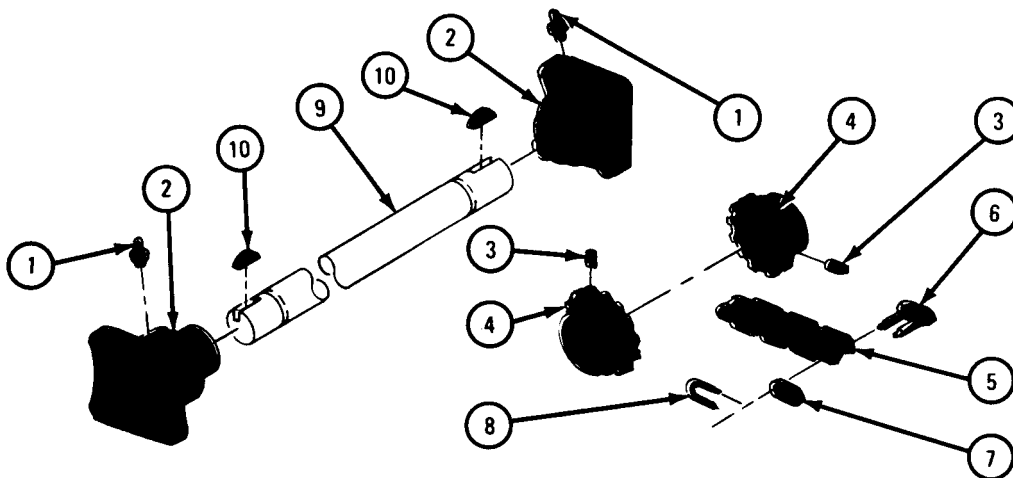

TA 047544

c. Replacement.

FRAME 1

1. Working in delivery compartment, slide coupling (1) onto delivery pump shaft (2).
  2. Using 1/8-inch allen wrench, screw in and tighten setscrew (3).
- GO TO FRAME 2

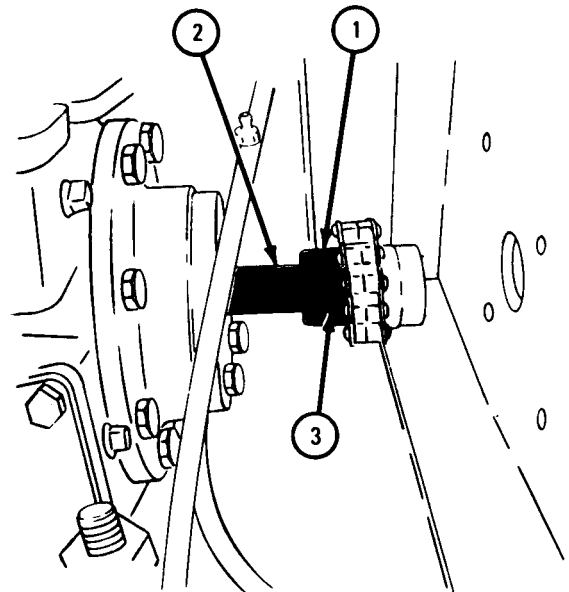
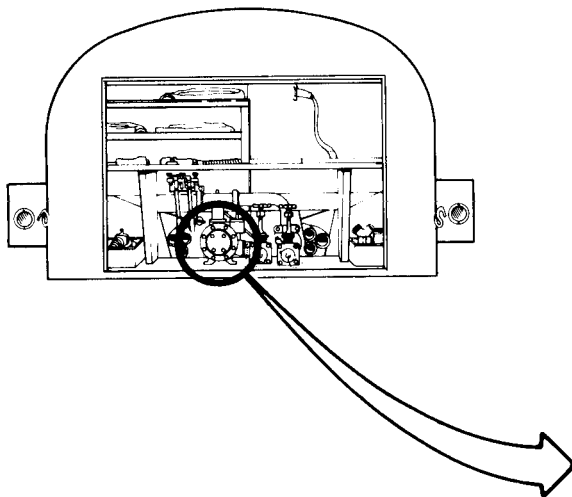

TA 047545

## FRAME 2

- Soldiers 1. Soldier A hold front of shaft (1) while soldier B holds rear of A and B shaft. Slide front of shaft through hole in bulkhead (2).
2. Push rear end of shaft (1) up and a few inches through hole in delivery compartment (3).

GO TO FRAME 3

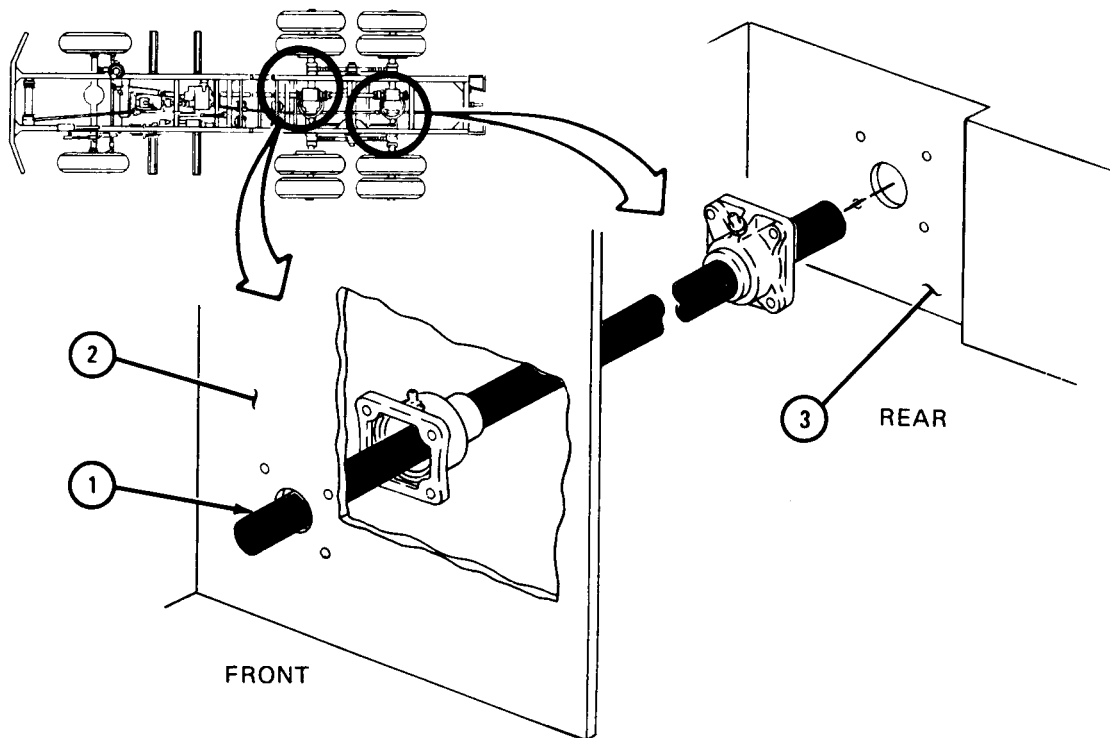

TA 047546

FRAME 3

- Soldier A 1. Aline woodruff key (1) on rear drive shaft (2) with keyway (3) in coupling half (4). Tell soldier B when ready.
- Soldier B 2. Working under truck, push on rear drive shaft (2) while soldier A guides it into coupling half (4).
- Soldier A 3. Guide rear drive shaft (2) into coupling half (4).
4. Using 1/8-inch allen wrench, screw in and tighten setscrew (5).
- GO TO FRAME 4

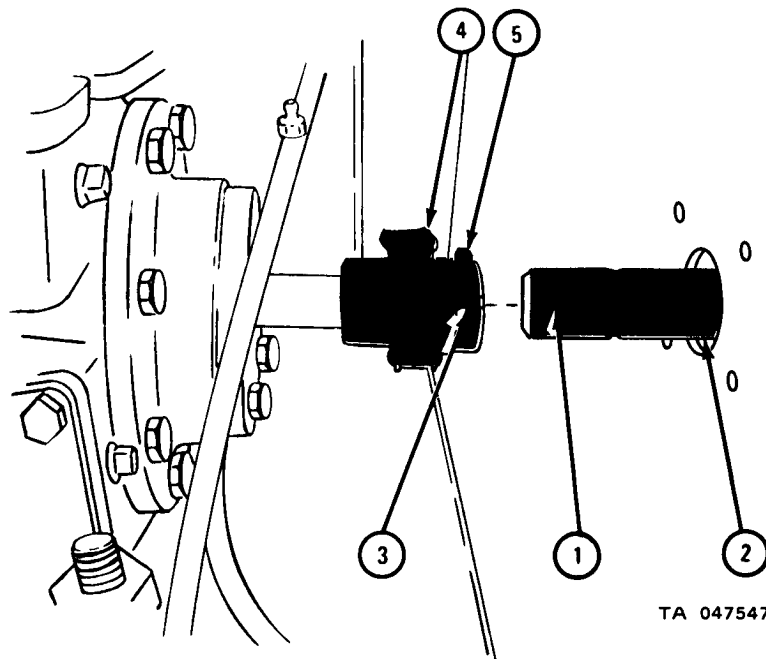

FRAME 4

- Soldier A 1. Put in four screws (1) and using 5/8-inch wrench, hold them in place.
- Soldier B 2. Slide bearing unit (2) onto four screws (1).
- Soldier A 3. Using 11/16-inch socket, ratchet, and extension, screw on and tighten four nuts (3).
4. Go to other end of shaft (4).
5. Close rear compartment doors.

GO TO FRAME 5

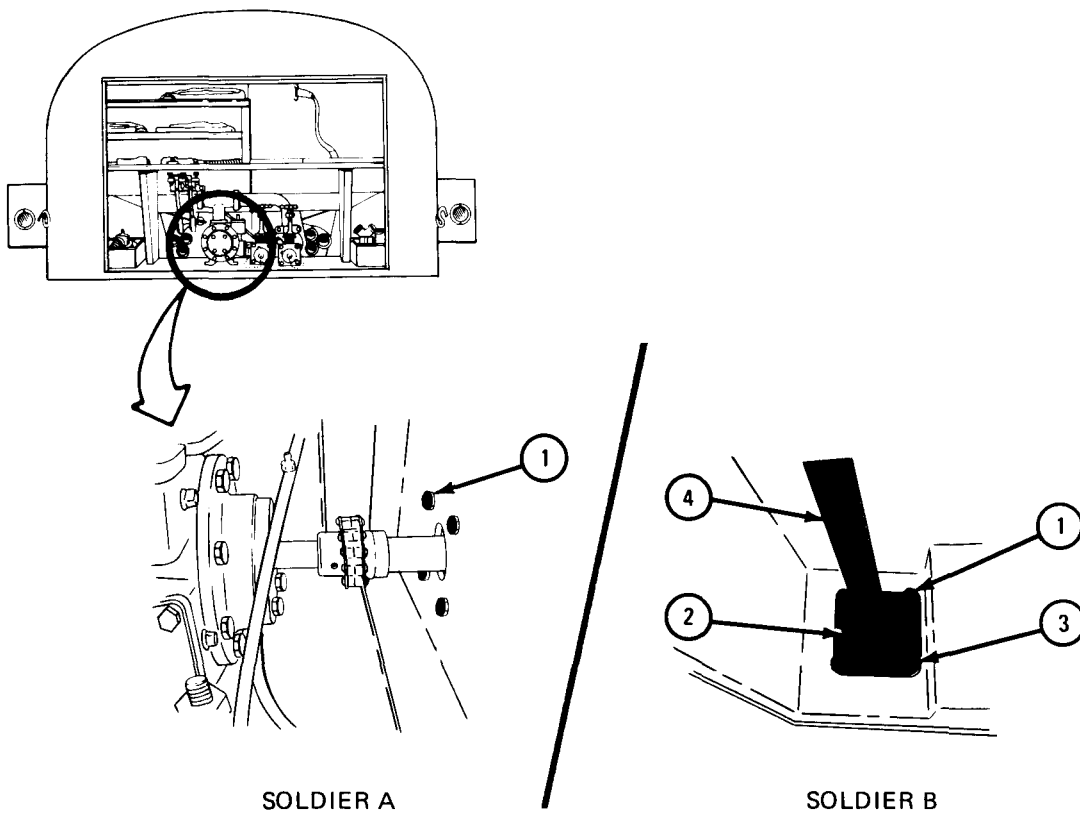

SOLDIER A

SOLDIER B

TA 047548

FRAME 5

1. Slide bearing unit (1) up against bulkhead (2).
2. Put four screws (3) through bulkhead (2) and bearing unit (1).
3. Using 11/16-inch and 5/8-inch wrenches, screw on and tighten four nuts (4).
4. Using 1/8-inch allen wrench, tighten two screws (5).

GO TO FRAME 6

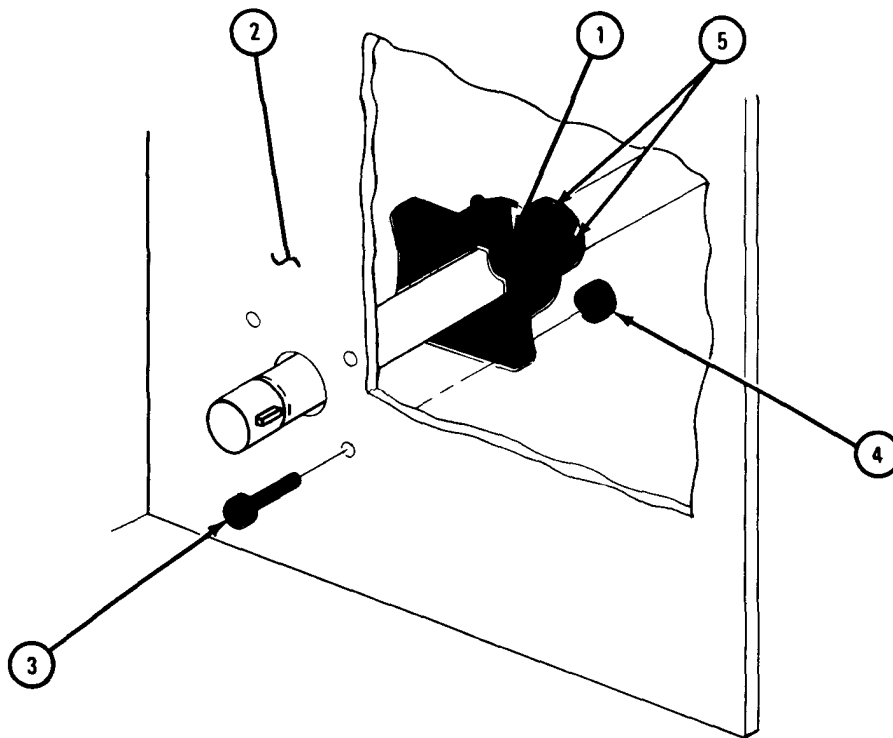

TA 047549

## FRAME 6

1. Aline woodruff key (1) on rear drive shaft (2) with keyway (3) in yoke (4).
2. Slide shaft (2) into yoke (4).
3. Using 3/16-inch allen wrench, screw in and tighten setscrew (5).
4. Go to other end of shaft (2).

GO TO FRAME 7

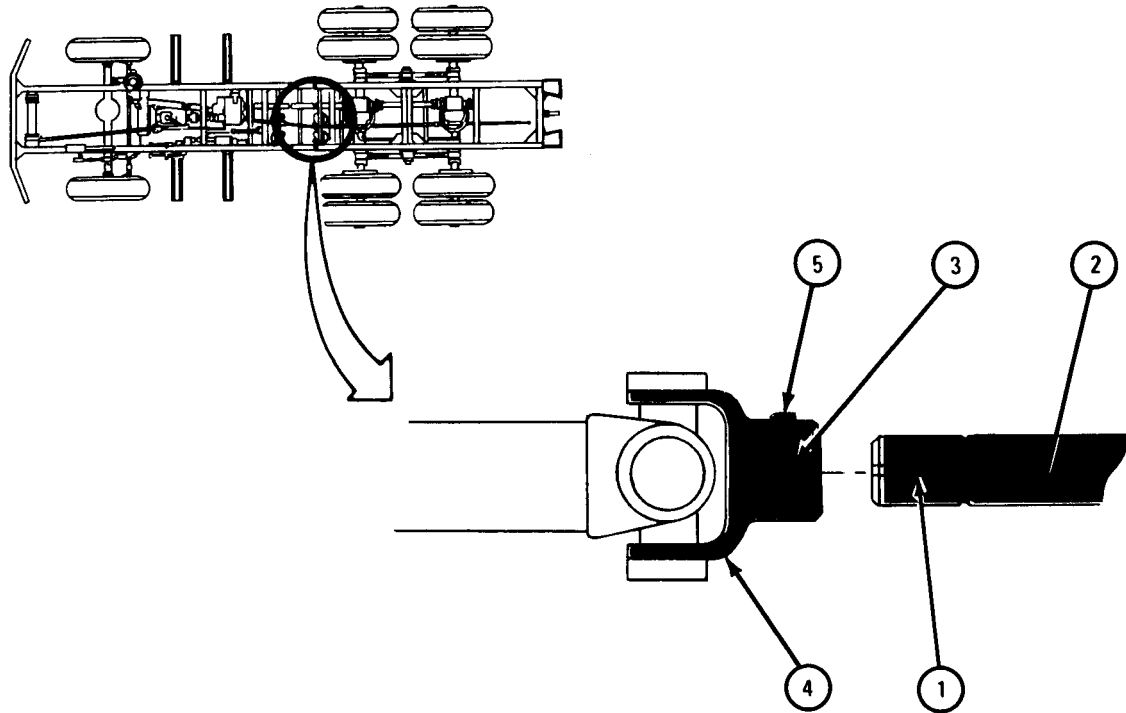

TA 047550

FRAME 7

1. Aline four holes in yoke (1) with holes in power take off flange (2).
2. Put in four bolts (3) and using 9/16-inch wrenches, screw on and tighten four nuts (4).

END OF TASK

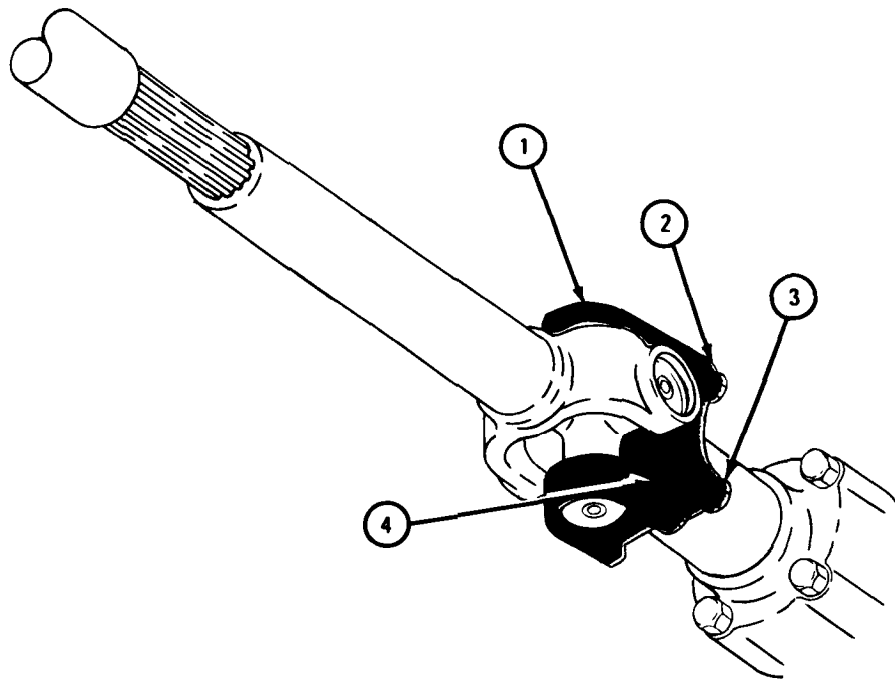

TA 047551



18-60. DISPENSER HOSE ASSEMBLY REMOVAL AND REPLACEMENT (TRUCKS M50A1, M50A2, AND M50A3).

TOOLS: Spanner wrench

SUPPLIES: None

PERSONNEL: One

EQUIPMENT CONDITION: Truck parked, engine off, handbrake set.

a. Removal.

FRAME 1

1. Open rear compartment doors (1).
2. Close discharge valve control levers (2) by pushing them toward front of truck.
3. Close both gate valves (3) by turning to right.
4. Using spanner wrench, unscrew and take off dust cover (4).
5. Take reducer coupling (5) out of rear compartment (6).
6. Using spanner wrench, screw on and tighten reducer coupling (5) to delivery valve (7).
7. Using spanner wrench, unscrew and take off dispenser hose (8).

END OF TASK

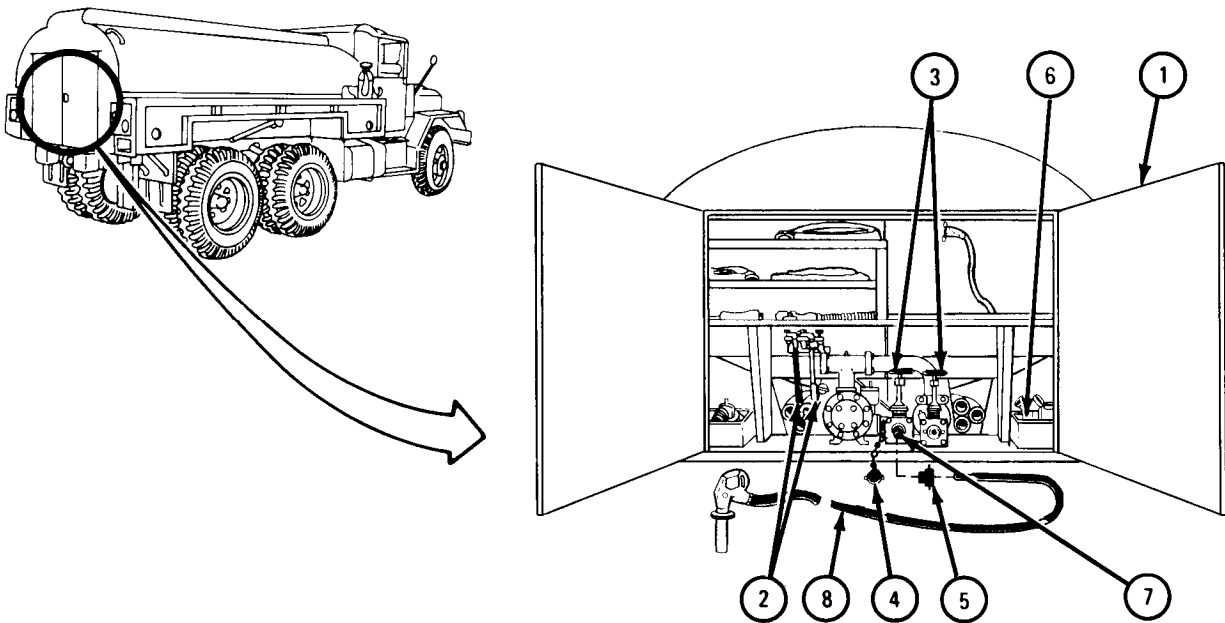

TA 047576

b. Replacement.

FRAME 1

1. Using spanner wrench, unscrew and take hose (1) off reducer coupling (2).
2. Using spanner wrench, unscrew and take off reducer coupling (2).
3. Using spanner wrench, screw on and tighten dust cover (3) to delivery valve (4).
4. Put reducer coupling (2) and dispenser hose (1) into rear compartment (5).
5. Close rear compartment doors (6).

END OF TASK

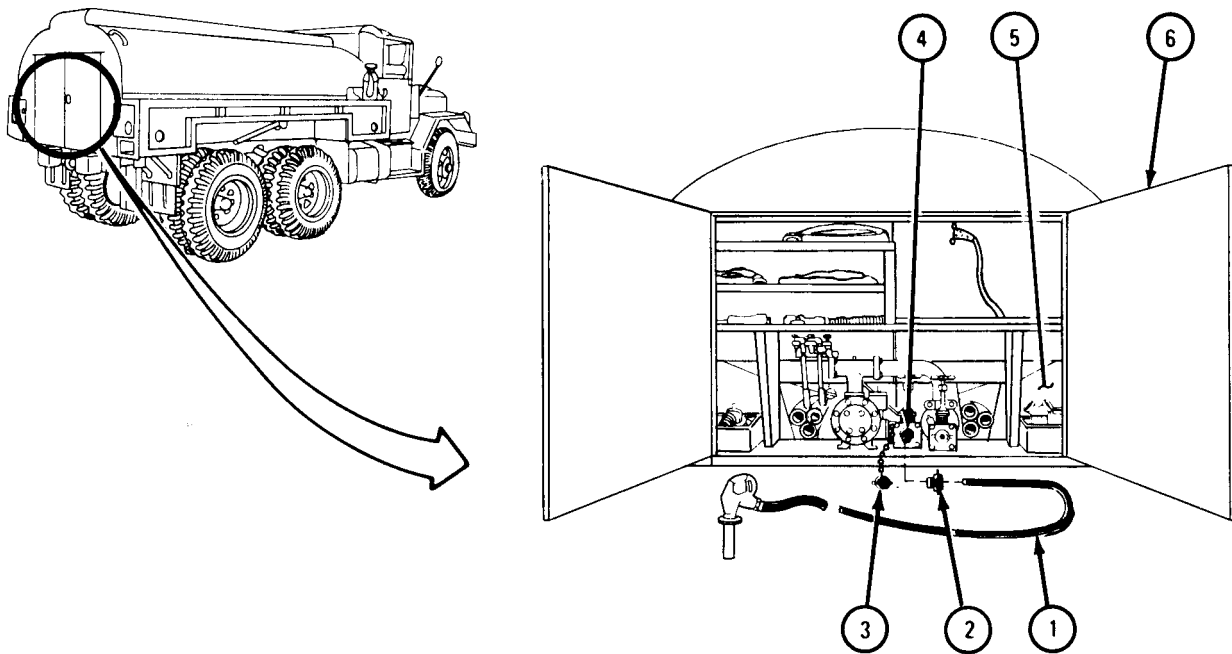

TA 047577

18-61. WATER DISCHARGE HOSES, DISPENSER NOZZLE, AND SUCTION STRAINER REMOVAL AND REPLACEMENT (TRUCKS M50A1, M50A2, AND M50A3).

TOOLS: Spanner wrench  
2 11/16-inch wrench

SUPPLIES: None

PERSONNEL: One

EQUIPMENT CONDITION: Truck parked, engine off, handbrake set.

- a. Preliminary Procedure. Open rear compartment doors.
- b. Removal.

FRAME 1

1. Using spanner wrench, unscrew and take off two hoses (1 and 2).
  2. Using spanner wrench, unscrew and take off reducer (3).
  3. Screw on and tighten two covers (4 and 5) to gate valves (6 and 7).
- GO TO FRAME 2

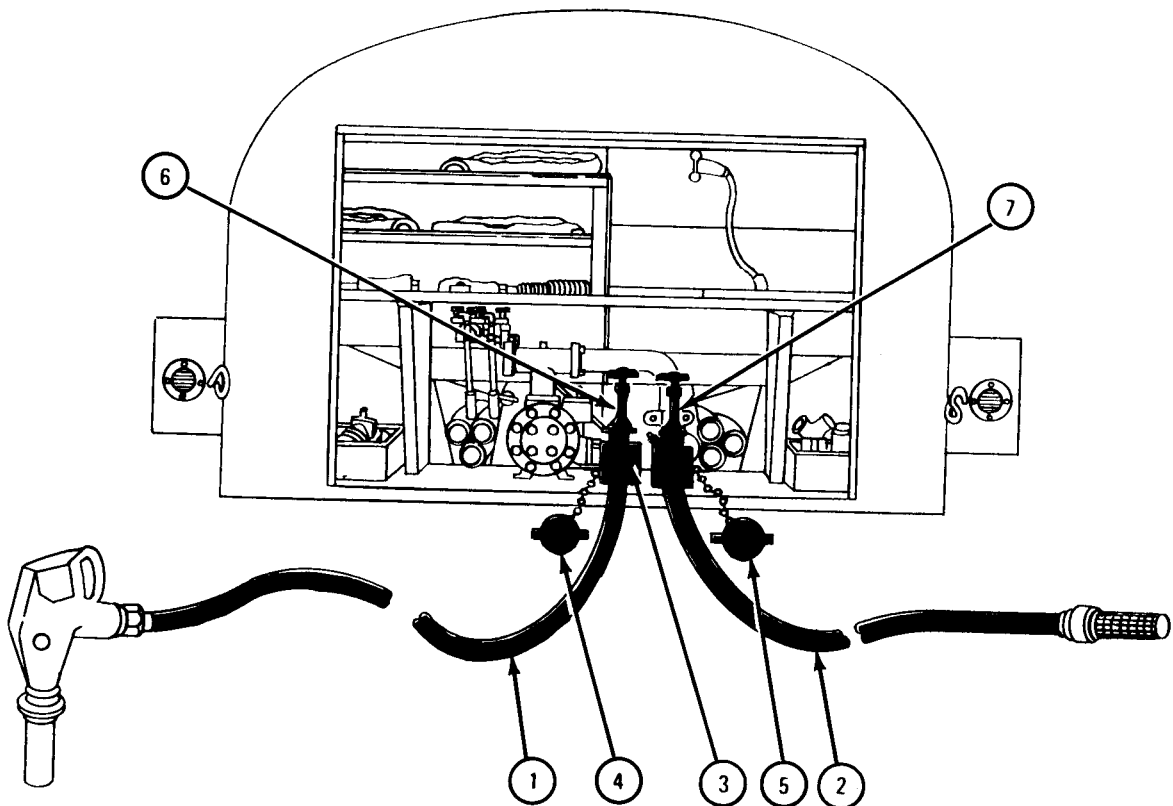

TA 083364

FRAME 2

1. Using 2 11/16-inch wrench, unscrew and take off nozzle (1) from hose (2).
2. Unscrew and take off strainer (3) from hose (4).

END OF TASK

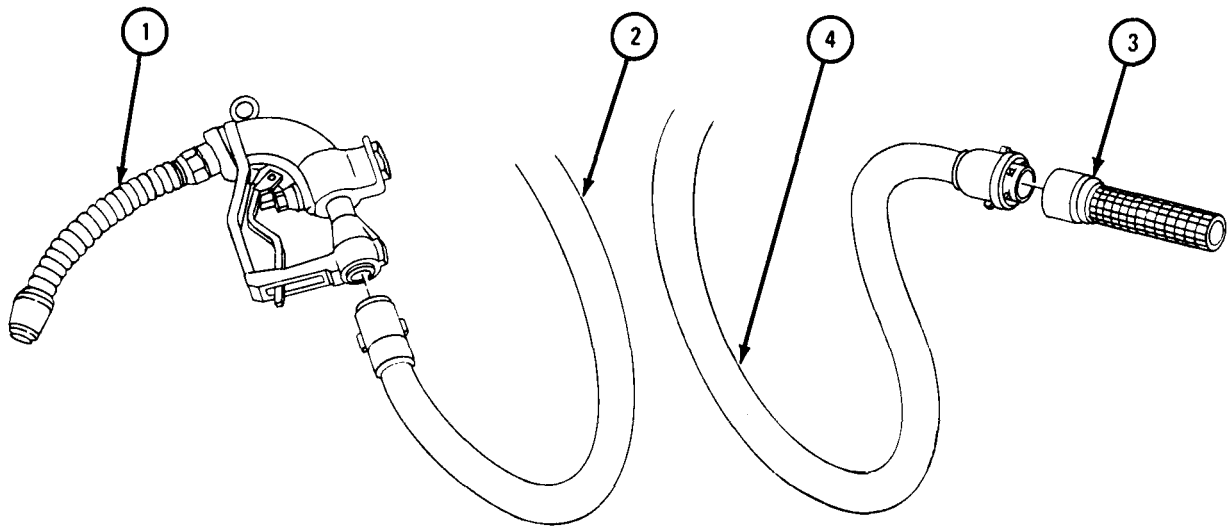

TA 083365

c. Replacement.

## FRAME 1

1. Screw on and tighten strainer (1) to hose (2).
  2. Using 2 11/16-inch wrench, screw on and tighten nozzle (3) to hose (4).
- GO TO FRAME 2

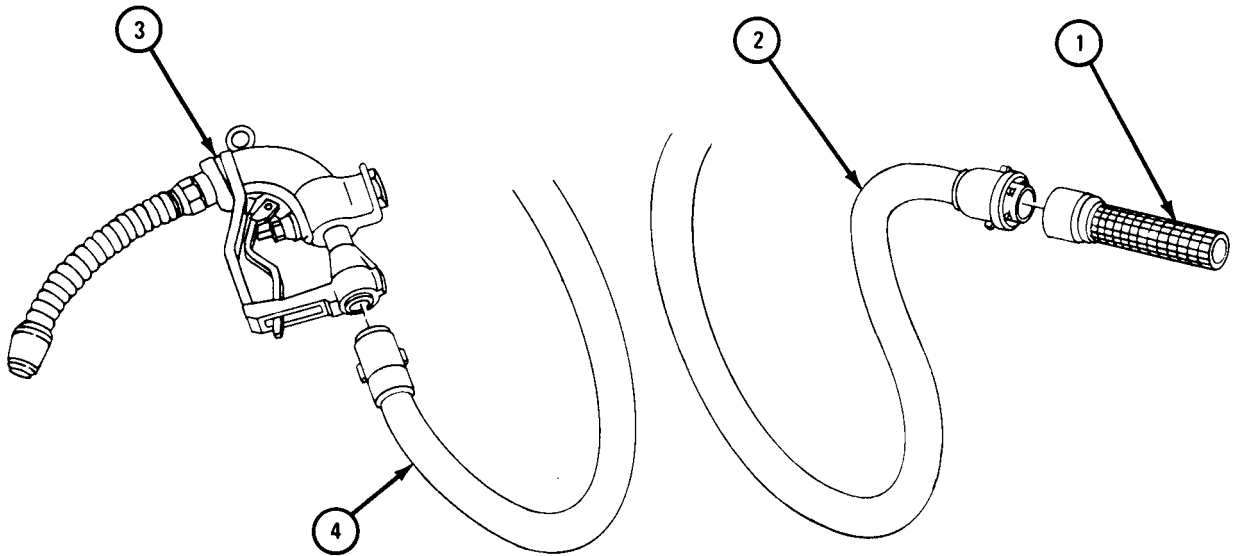

TA 083366

FRAME 2

1. Unscrew and take off two covers (1 and 2) from gate valves (3 and 4).
2. Using spanner wrench, screw on and tighten reducer (5) to gate valve (3).
3. Using spanner wrench, screw on and tighten two hoses (6 and 7) to two gate valves (3 and 4).

NOTE

Follow-on Maintenance Action Required:

Close rear compartment doors.

END OF TASK

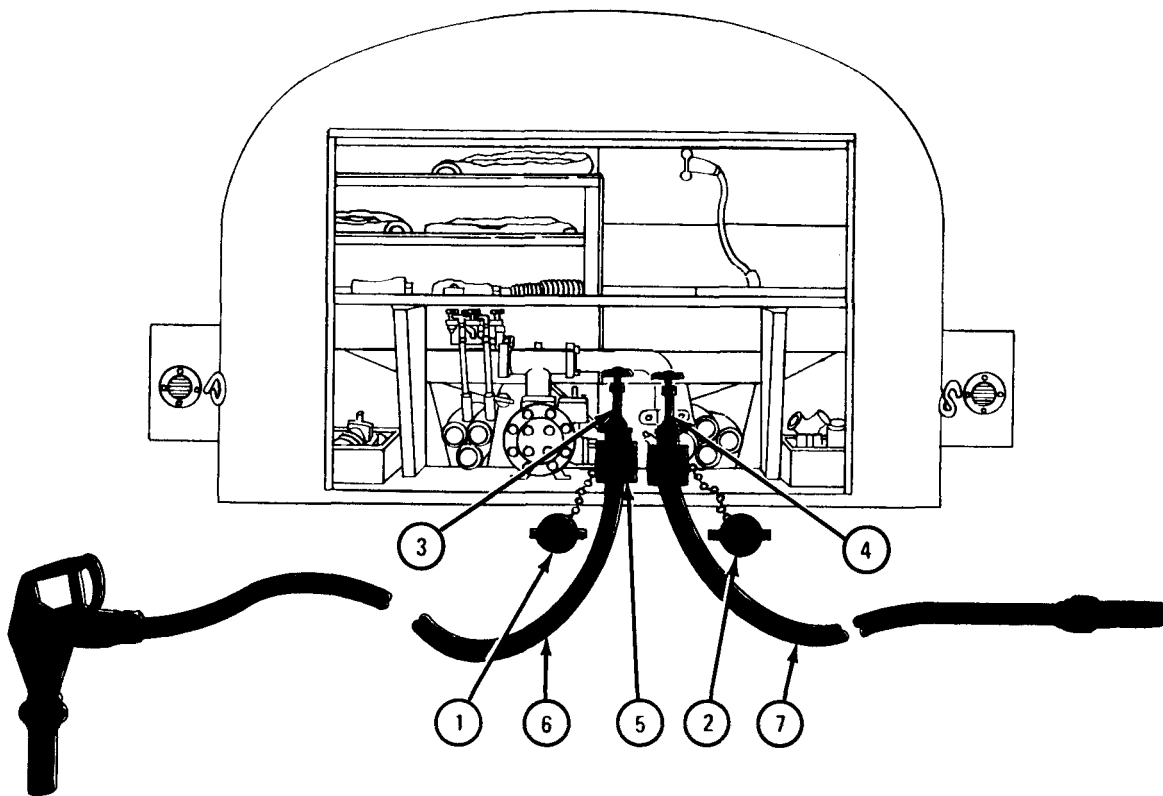

TA 083367

18-62. MANHOLE COVERS REMOVAL, REPAIR, AND REPLACEMENT (TRUCKS M50A1 AND M50A2).

TOOLS: 15/16-inch open end wrench  
11/16-inch open end wrench  
Pliers

SUPPLIES: None

PERSONNEL: One

EQUIPMENT CONDITION: Truck parked, engine off, handbrake set.

a. Removal of Outer Manhole Cover.

FRAME 1

1. Take off padlock (1).

NOTE

The number of flat space washers (4) may vary from truck to truck.

2. Using pliers, take out and throw away cotter pin (2). Slide out pin (3), and take out five flat space washers (4).
3. Unlatch handle (5) and pull up yoke (6).
4. Take off cover (7) and gasket (8).

END OF TASK

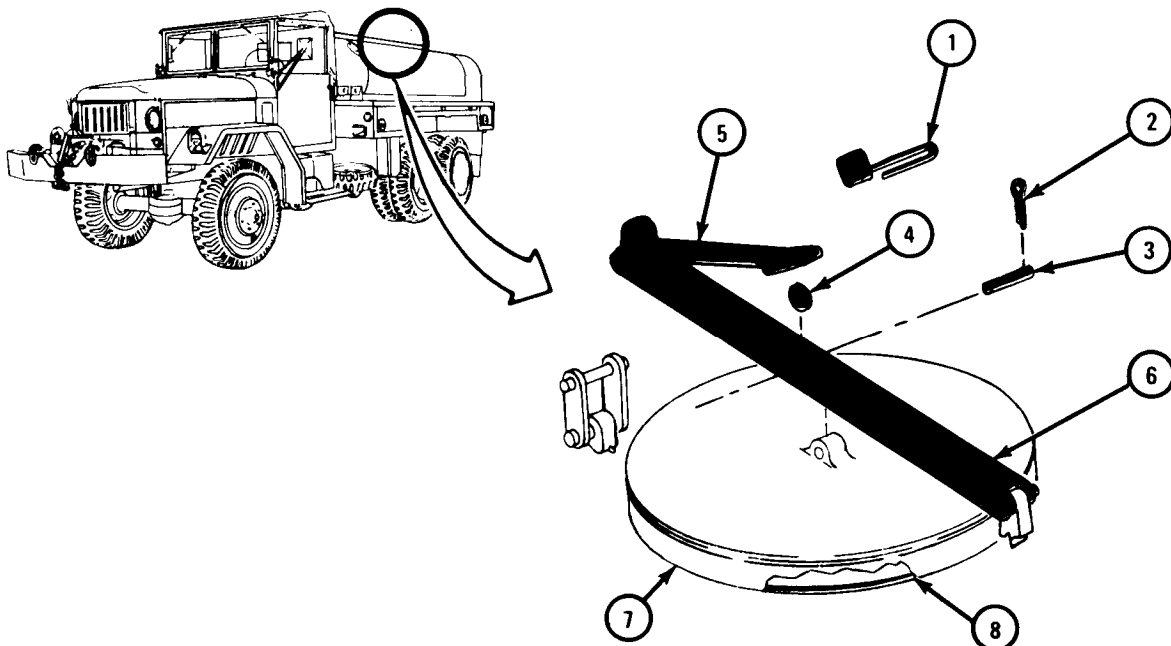

TA 047552

b. Removal of Inner Manhole Cover.

FRAME 1

1. Using pliers, take out and throw away two cotter pins (1). Slide out pins (2).

NOTE

Cover (3) may need to be turned left or right before pulling it all the way out.

2. Grab yoke (4) and pull out cover (3).
3. Pull out rubber seal (5).

END OF TASK

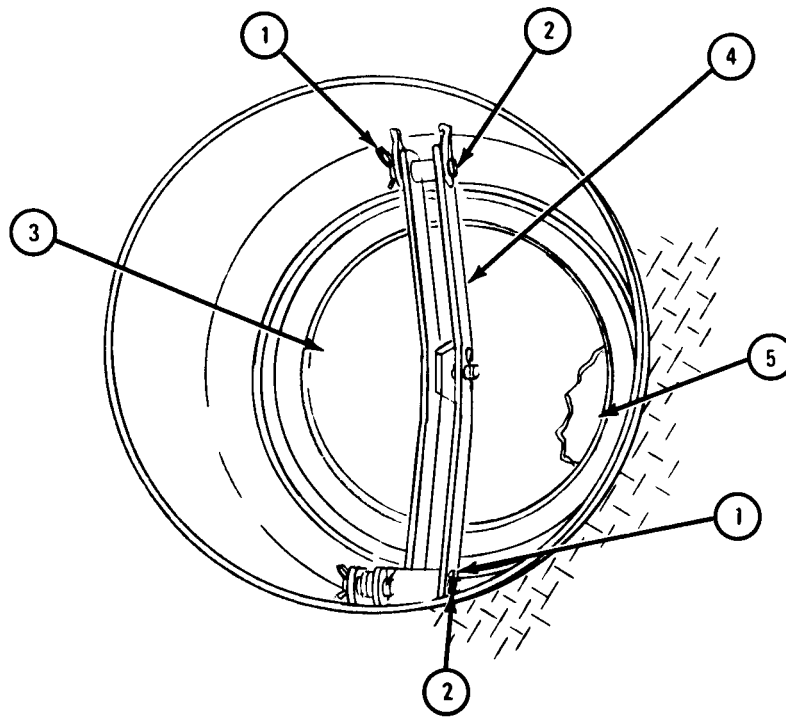

TA 047553



c. Repair of Inner Manhole Cover.

(1) Disassembly.

## FRAME 1

1. Using pliers, pull out and throw away four cotter pins (1).
2. Take out two pins (2) and five flat space washers (3). Pull apart yoke (4) from cover (5).
3. Using 11/16-inch and 15/16-inch wrench, unscrew and take out two eyebolts (6) from nut (7).

END OF TASK

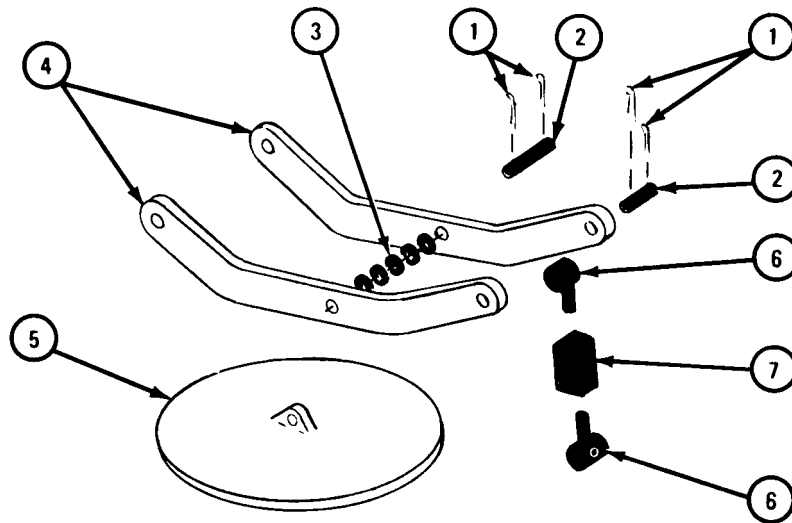

TA 047554

(2) Repair. Check that all parts have no damage or wear. If part is damaged, get a new one. Check that rubber seal has no cuts, cracks or wear. If seal is damaged, get a new one.

(3) Assembly.

FRAME 1

1. Aline center holes in each half of yoke (1) with each side of hole in cover (2).
2. Put in pin (3), five flat space washers (4), and two cotter pins (5). Using pliers, bend open ends of cotter pins.
3. Screw two eyebolts (6) partway into each side of nut (7).
4. Put eyebolt (6) between holes in end of yoke (1) and slide through pin (8). Put in two cotter pins (9). Using pliers, bend open ends of cotter pin.

END OF TASK

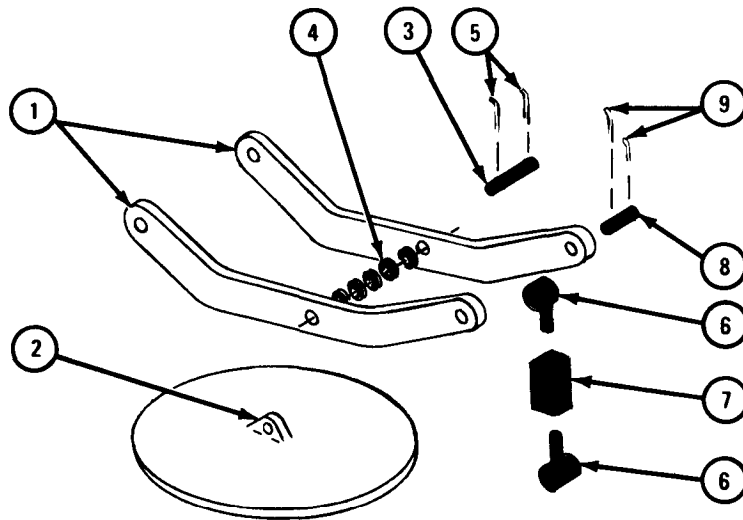

TA 047555

d. Repair of Outer Manhole Cover.

## FRAME 1

1. Check that cover (1) has no cracks, dents, holes or wear. If cover is damaged, get a new one.
2. Check that gasket (2) has no cracks, breaks or wear. If gasket is damaged, get a new one.

END OF TASK

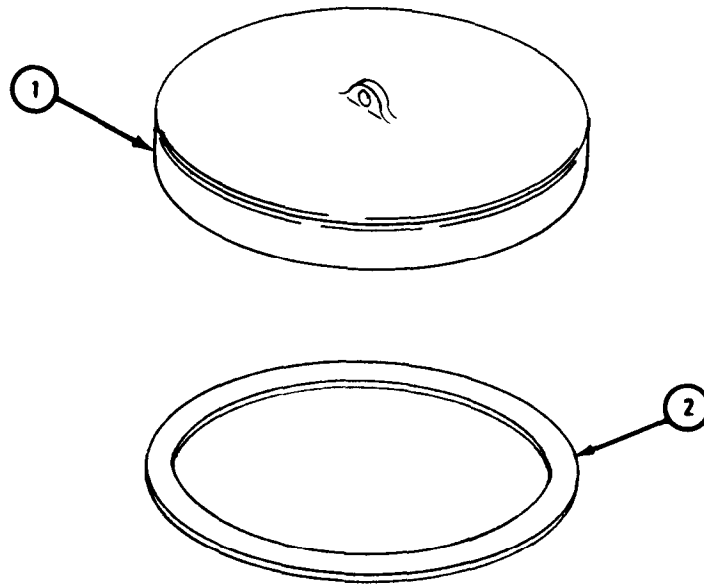

TA 047556

e. Replacement of Inner Manhole Cover.

FRAME 1

1. Place rubber seal (1) around ridge in bottom of manhole (2).
- GO TO FRAME 2

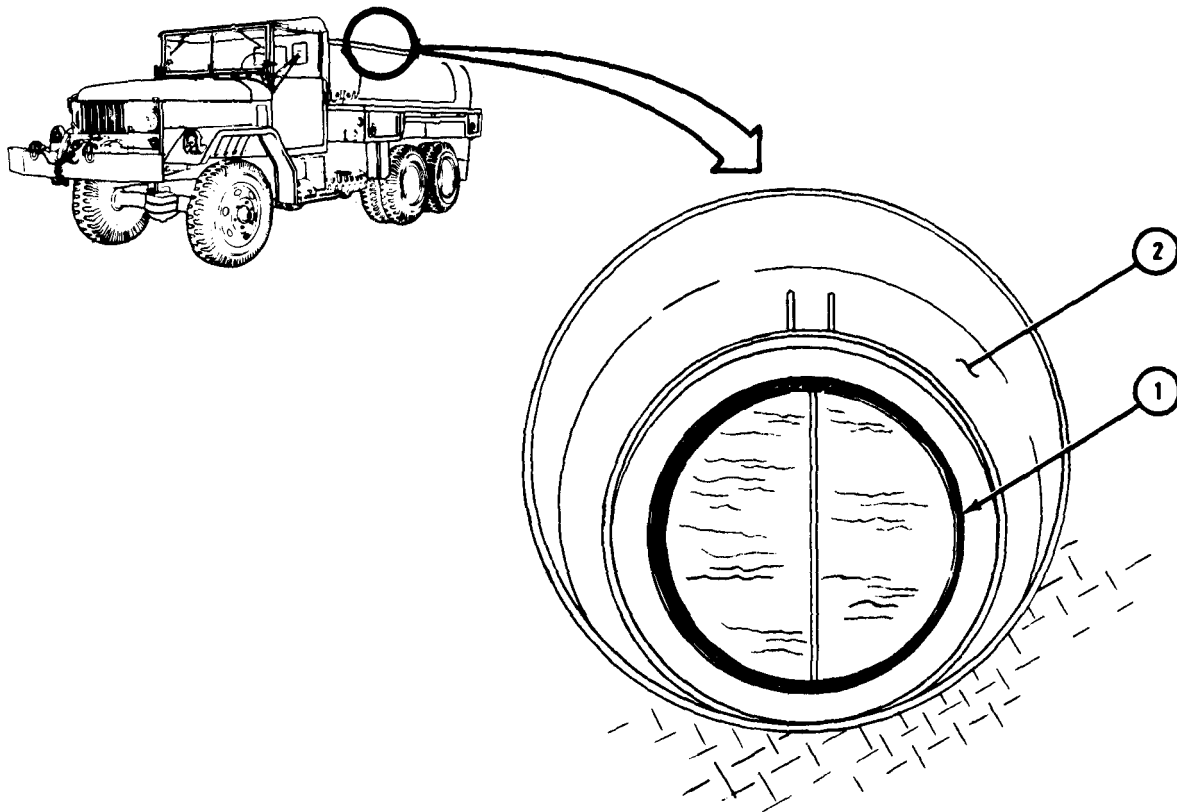

TA 047557

## FRAME 2

## NOTE

Cover (1) may need to be turned left or right before lowering so that ends of yoke (2) clear pad eyes (4).

1. Put on inner cover (1) so that end of yoke (2) with eyebolt (3) lines up under upper pad eye (4).
2. Place other end of yoke (2) in lower pad eye (4).
3. Push in pin (5). Put in cotter pin (6). Using pliers, bend open ends of cotter pin.
4. Put end of eyebolt (3) in upper pad eye (4).

## NOTE

Adjustment may be needed to push pin (7) through holes in pad eye (4) and eyebolt (3). Turn eyebolt nut (9) left or right as needed to line up holes.

5. Put in pin (7). Put in cotter pin (8). Using pliers, bend open ends of cotter pin.

GO TO FRAME 3

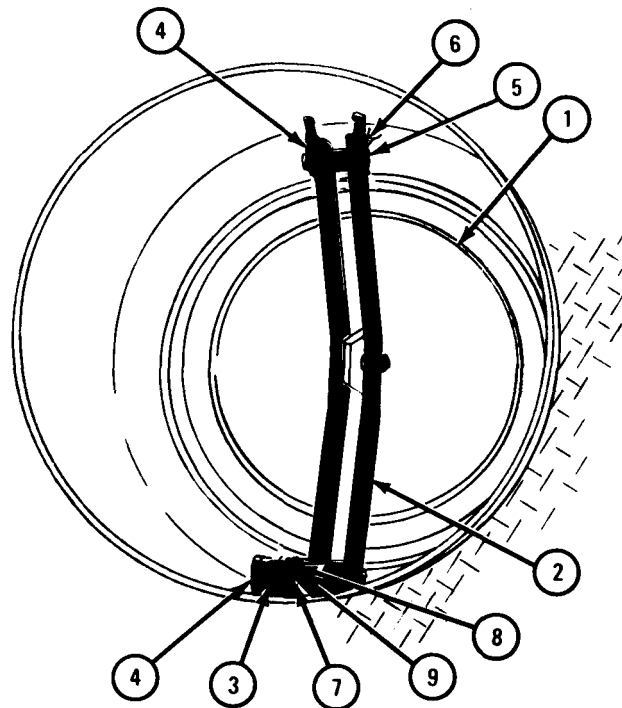

TA 047558

FRAME 3

1. Using 15/16-inch wrench, turn eyebolt nut (1) left until it is tight.
  2. Feel around edge of cover (2) to be sure cover is down and sealed.
- END OF TASK

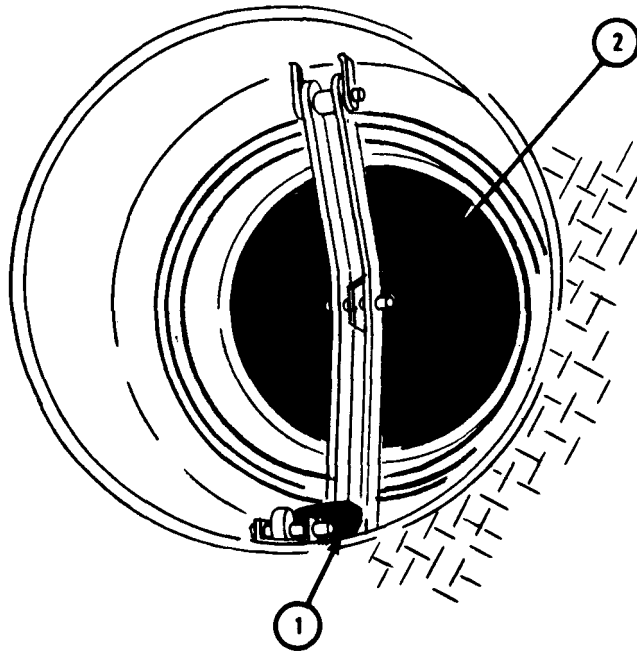

TA 047559

f. Replacement of Outer Manhole Cover.

## FRAME 1

## NOTE

Be sure area around manhole opening is clean before putting on cover (1).

1. Place outer manhole cover (1) with gasket (2) over manhole opening.
2. Swing yoke (3) down over cover (1).
3. Aline center holes in yoke (3) with hole in top of cover (1). Put two washers (4) between hole in top of cover and one arm of yoke. Put three washers between hole in top of cover and other arm of yoke.
4. Push in pin (5).
5. Put in cotter pin (6). Using pliers, bend open ends of cotter pin.
6. Lock handle (7) in hinge (8).
7. Put padlock (9) through hole in handle (7) and yoke (3). Lock padlock.

END OF TASK

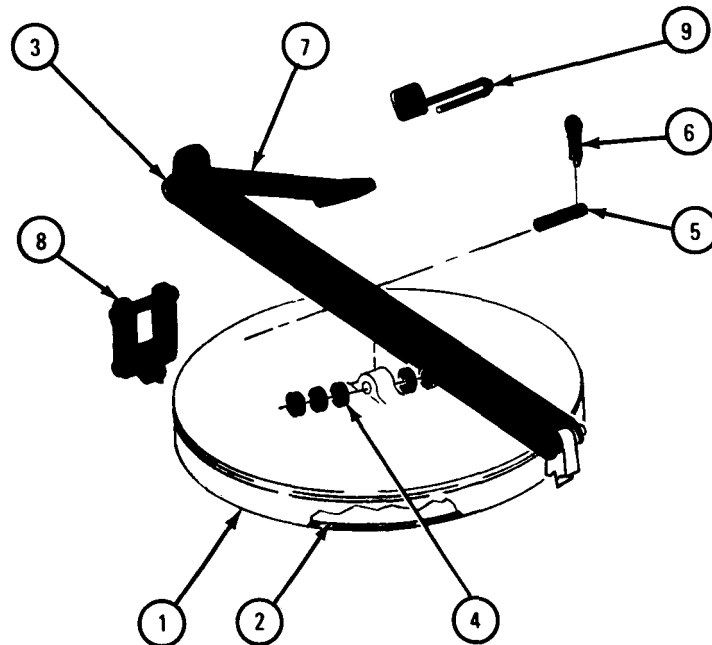

TA 047560

18-63. MANHOLE COVER (M50A3) REMOVAL, REPAIR, AND REPLACEMENT.

TOOLS: 9/16-inch open end wrench (2)  
Scraper  
Rubber mallet

SUPPLIES: Gasket cement  
Solvent, dry cleaning, Type 11 (SD-2), Fed. Spec. P-D-680

PERSONNEL: One

EQUIPMENT CONDITION: Truck parked, engine off, handbrake set.

a. Removal.

FRAME 1

1. Take off padlock (1).
2. Using 9/16-inch open end wrenches, unscrew and take off nut (2) and washer (3).
3. Take out bolt (4).
4. Spread and take off clamp ring (5).
5. Lift off manhole cover (6).

END OF TASK

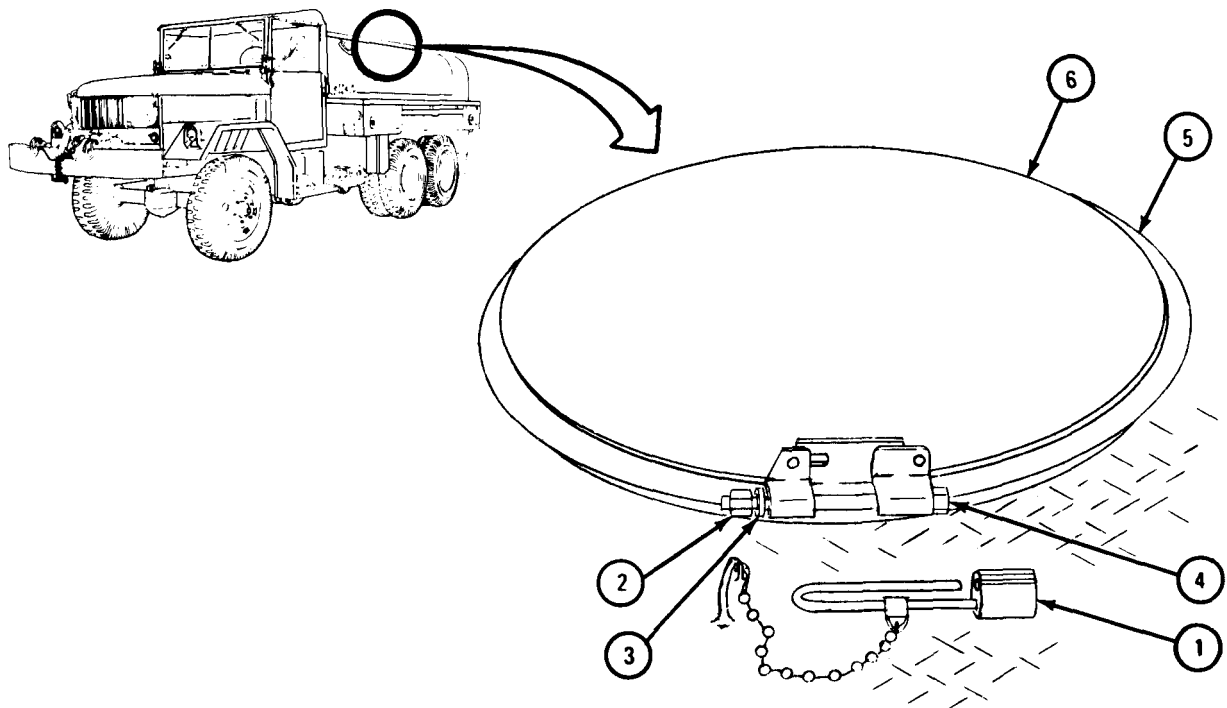

TA 047561



b. Repair.

## FRAME 1

1. Check cork gasket (1) for cracks, cuts, missing pieces or wear.
2. If cork gasket (1) is damaged, use scraper to scrape it off manhole cover (2).
3. Check manhole cover (2) for dents, cracks, holes or other damage. If manhole cover is damaged, get a new one in its place.

WARNING

Dry cleaning solvent is flammable. Do not use near an open flame. Keep a fire extinguisher nearby when solvent is used. Use only in well-ventilated places. Failure to do this may result in injury to personnel and damage to equipment.

4. Using solvent, clean all old gasket cement off rim (3) of manhole cover (2).

END OF TASK

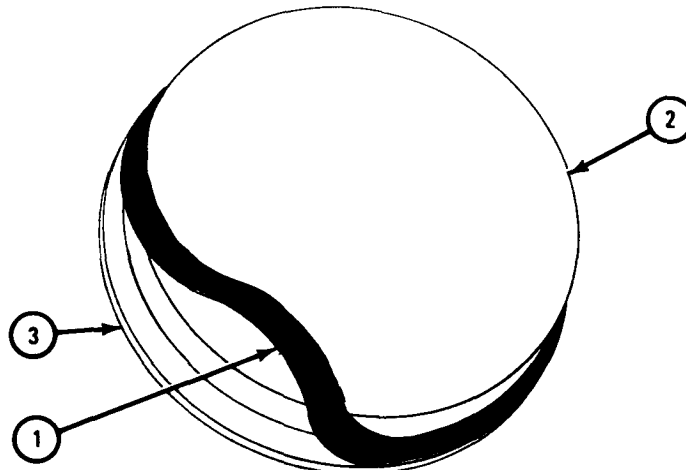

TA 047562

c. Replacement.

NOTE

If cork gasket was not taken off manhole cover,  
go to frame 2.

FRAME 1

1. Spread gasket cement on inside rim of manhole cover (1).
  2. Press cork gasket (2) in place around inside rim of manhole cover (1).
- GO TO FRAME 2

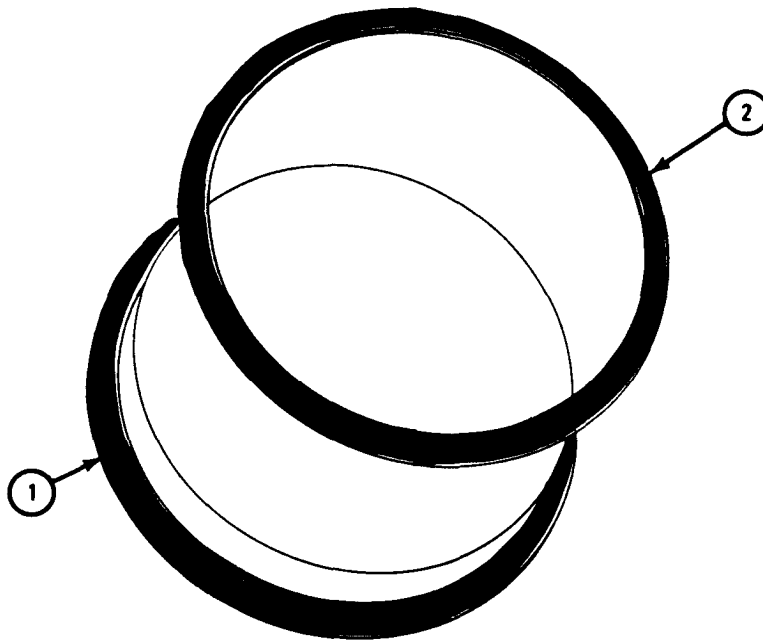

TA 047563

## FRAME 2

1. Check flange (1) around manhole (2) to make sure it is clean.
2. Place manhole cover (3) over manhole (2).

GO TO FRAME 3

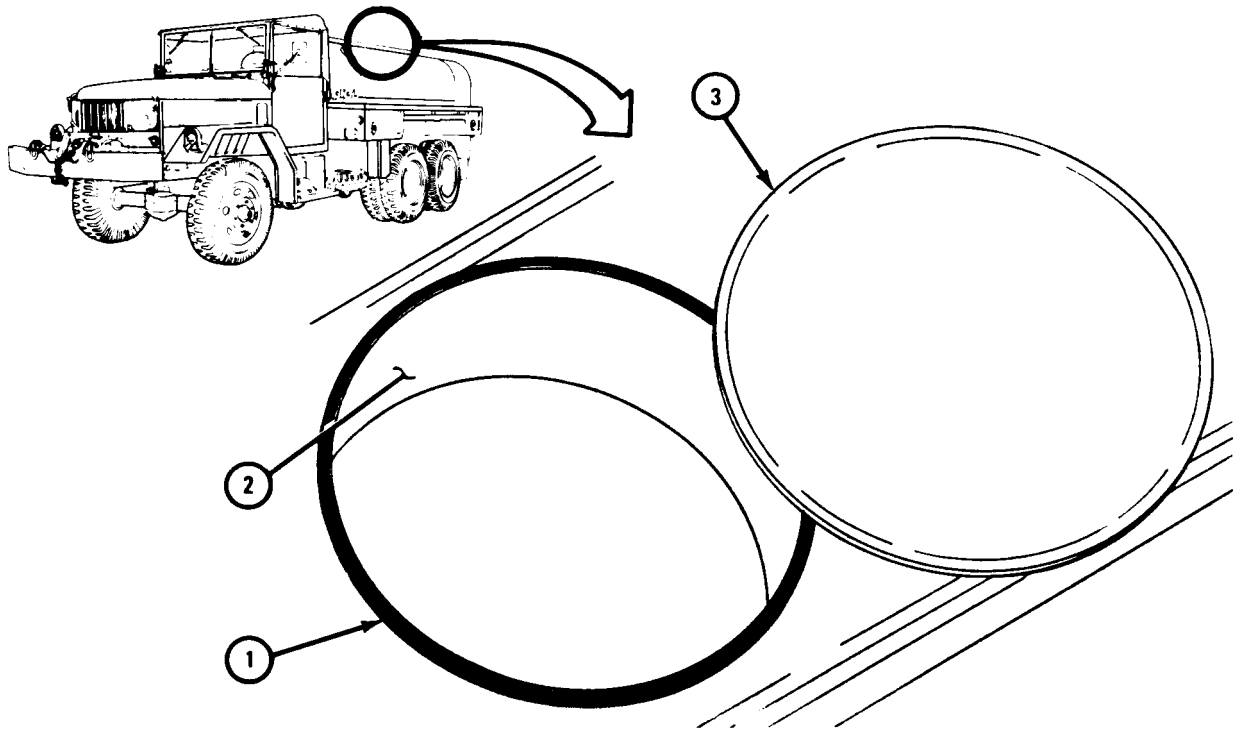

TA 047565

FRAME 3

1. Spread clamp ring (1) and put it around manhole cover (2).
2. Put bolt (3) through two clamp ring brackets (4).
3. Put on washer (5) and screw on nut (6).

CAUTION

Do not overtighten nut (6) or clamp ring brackets (4) may break. When tightening nut, using rubber mallet, tap the other side of clamp ring (1) towards clamp ring brackets.

4. Tighten bolt (3) and nut (6) a little at a time by hand, using mallet to tap clamp ring.
5. Using 9/16-inch wrenches, tighten bolt (3) and nut (6).
6. Put padlock (7) through holes in clamp ring brackets (4) and lock it.

END OF TASK

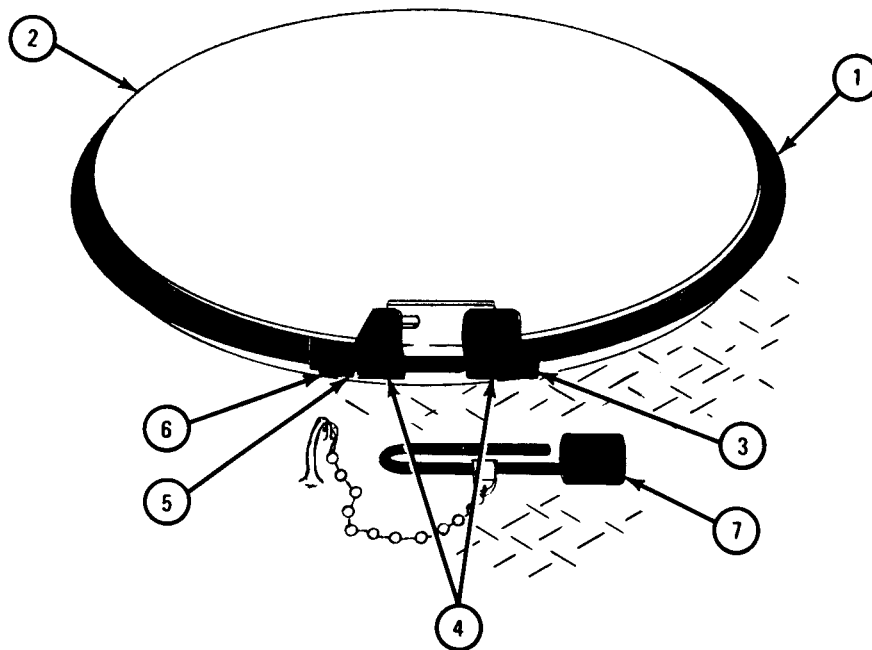

TA 047566

18-64. WATER TANK FILLER COVER REMOVAL, CLEANING, INSPECTION, REPAIR, AND REPLACEMENT (TRUCKS M50A1, M50A2 AND M50A3).

TOOLS: 6-inch pliers

SUPPLIES: Clean rags

PERSONNEL: One

EQUIPMENT CONDITION: Truck parked, engine off, handbrake set.

a. Removal.

FRAME 1

NOTE

Some trucks have only one cotter pin (1).

1. Using pliers, take out and throw away two cotter pins (1).
2. On trucks M50A1 and M50A2, unlatch handle (2).
3. Slide out pin (3).
4. Pull up yoke (4).
5. Take off cover (5) and gasket (6).

END OF TASK

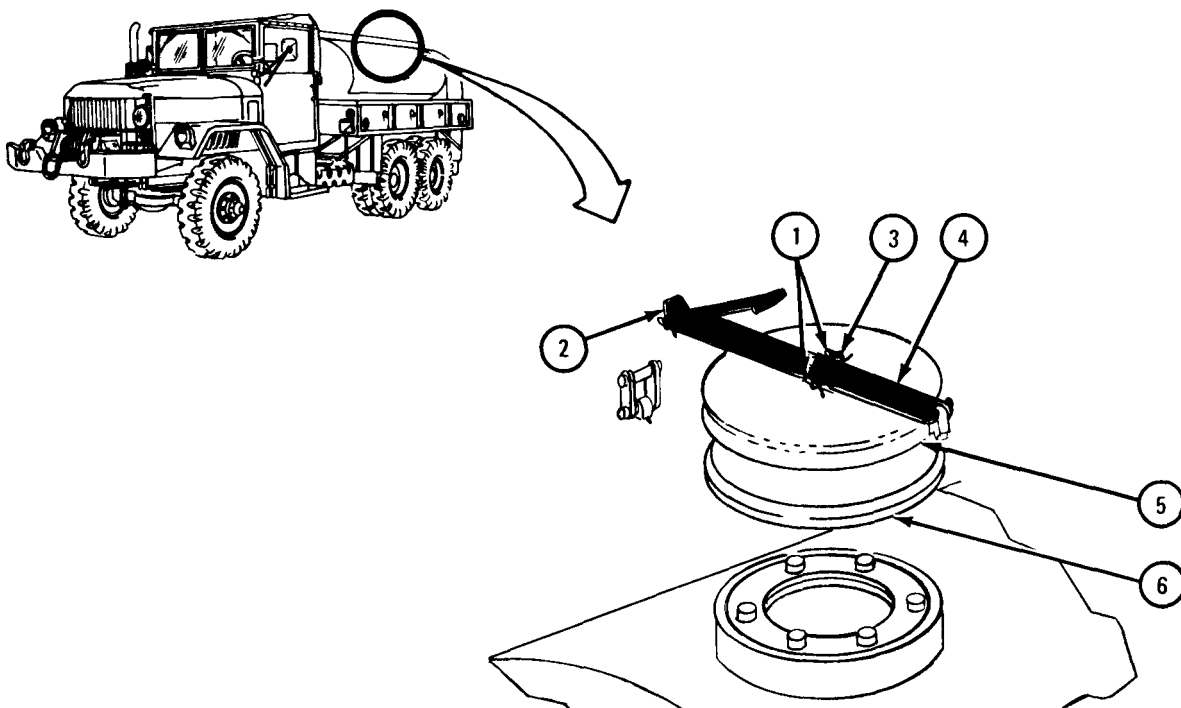

TA 101164

- b. Cleaning. Steam clean filler cover and dry with clean rags.
- c. Inspection and Repair. Check that filler cover and gasket have no damage or wear. If part is damaged, get a new one.
- a. Replacement.

FRAME 1

1. Place filler cover (1) and gasket (2) over opening for filler cover.
2. Swing yoke (3) down over filler cover (1) .
3. Aline center holes in yoke (3) with hole in top of filler cover (1) and push pin (4) through holes.

NOTE

Some trucks have only one cotter pin (5).

4. Put two cotter pins (5) into pin (4). Using pliers, bend open ends of cotter pins.
5. On trucks M50A1 and M50A2, lock handle (6) in hinge (7).

END OF TASK

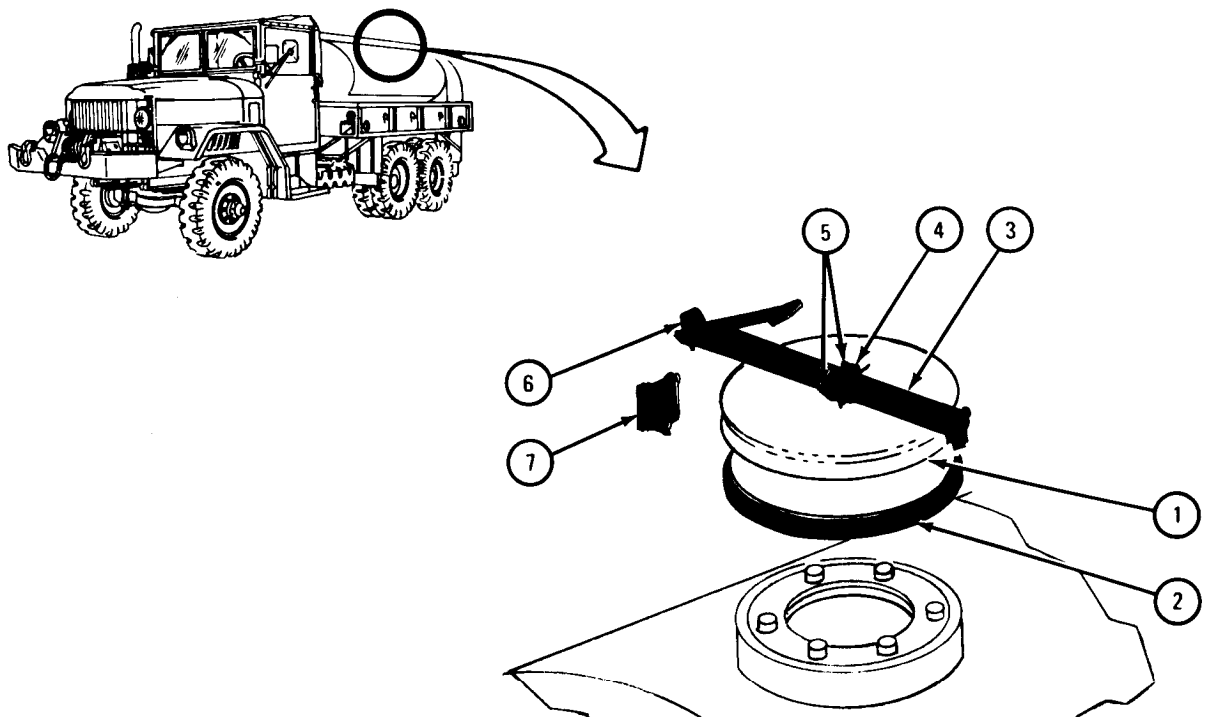

TA 101165

Section VIII. SPECIAL PURPOSE BODIES

18-65. 24-VOLT AND 115-VOLT DOME LIGHT ASSEMBLIES REMOVAL AND REPLACEMENT (TRUCKS M109A2, M109A3, M185A2, AND M185A3).

NOTE

There are six 115-volt dome lights (three on each side of ceiling). There are two 24-volt dome lights in center ceiling. This task is the same for all dome light assemblies.

TOOLS: Flat-tip screwdriver

SUPPLIES: Tags

PERSONNEL: One

EQUIPMENT CONDITION: Truck parked, engine off, handbrake set.

a. Preliminary Procedures.

(1) If working on 24-volt dome light assembly, disconnect battery ground cable. Refer to Part 1, para 7-58.

(2) If working on 115-volt dome light assembly, turn off 115-volt circuit breaker. Refer to TM 9-2320-209-10.

b. Removal.

FRAME 1

1. Using screwdriver, unscrew and take out lockscrew (1), while holding up light door (2).

2. Open light door (2) and let door hang open.

GO TO FRAME 2

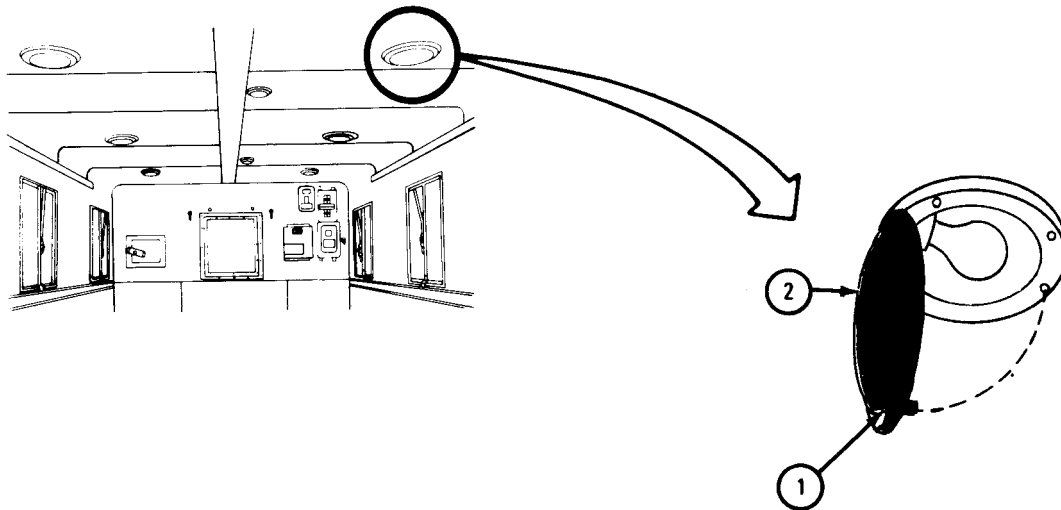

TA 047454

FRAME 2

1. Using screwdriver, unscrew and take out four screws (1).

NOTE

Hold light assembly so it does not hang by wires.

Tag wires and terminals before taking them off, so they can be put back in the right place.

2. Using screwdriver, unscrew and take off two screws (2) and two wires (3).

END OF TASK

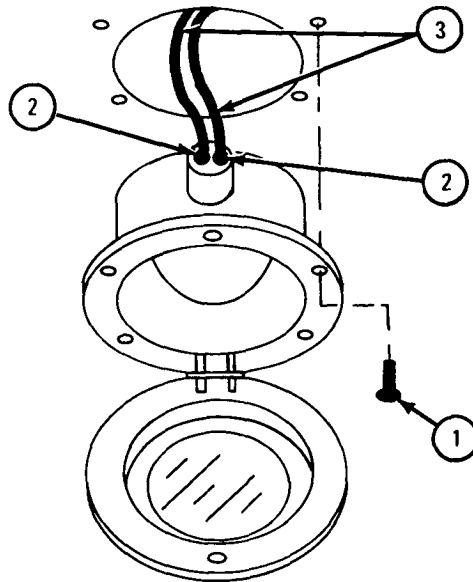

TA 047455



c. Replacement.

## FRAME 1

1. Using screwdriver, screw in and tighten two screws (1) with two wires (2) as tagged. Take off tags.
2. Put light assembly (3) in ceiling and align four holes.
3. Using screwdriver, screw in and tighten four screws (4).

GO TO FRAME 2

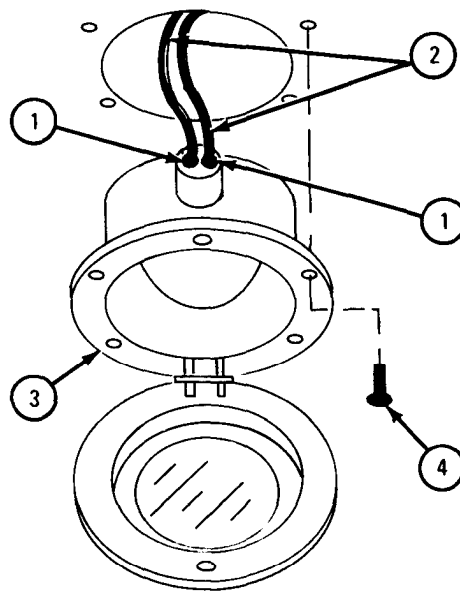

TA 047456

FRAME 2

1. Close light door (1).
2. Using screwdriver, screw in and tighten lockscrew (2).

NOTE

Follow-on Maintenance Action Required:

1. If 24-volt dome light assembly was worked on, reconnect battery ground cable. Refer to Part 1, para 7-58.
2. If 115-volt dome light assembly was worked on, turn on 115-volt circuit breaker. Refer to TM 9-2320-209-10.

END OF TASK

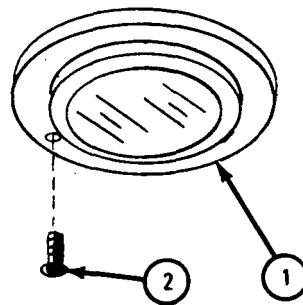
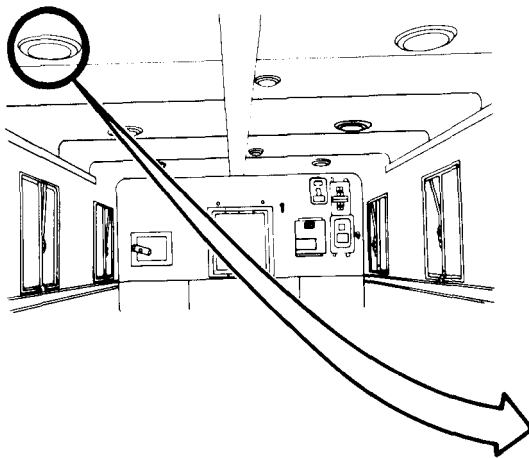

TA 047457

18-66. 24-VOLT DOME LIGHT LAMP REMOVAL AND REPLACEMENT (TRUCKS M109A2, M109A3, M185A2, AND M185A3).

TOOLS: Flat-tip screwdriver

SUPPLIES: None

PERSONNEL: One

EQUIPMENT CONDITION: Truck parked, engine off, handbrake set.

a. Preliminary Procedures.

(1) Turn off 24-volt dome light circuit breaker. Refer to TM 9-2320-209-10.

(2) Disconnect battery ground cable. Refer to Part 1, para 7-58.

b. Removal.

FRAME 1

1. Using screwdriver, unscrew and take out lockscrew (1) while holding light door (2) up.
2. Open light door (2) and let it hang open.
3. Push lamp (3) in, turn it to left, and take out lamp.

END OF TASK

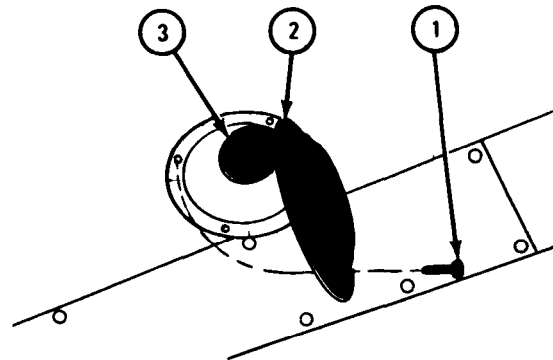
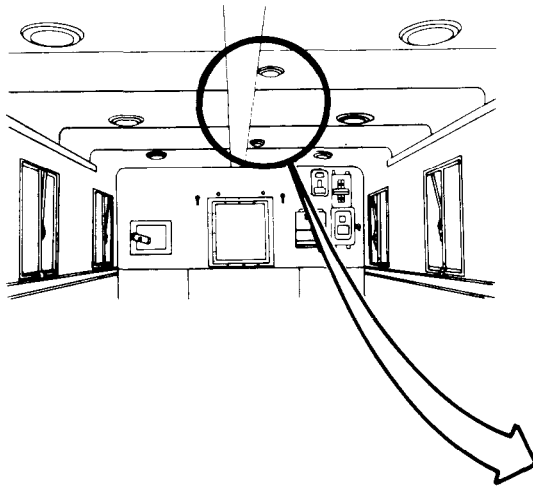

TA 047449

c. Replacement.

FRAME 1

1. Push in lamp (1) and turn to right.
2. Close light door (2).
3. Using screwdriver, screw in and tighten screw (3).

NOTE

Follow-on Maintenance Action Required:

1. Reconnect battery ground cable. Refer to Part 1, para 7-58.
2. Turn on 24-volt dome light circuit breaker. Refer to TM 9-2320-209-10.

END OF TASK

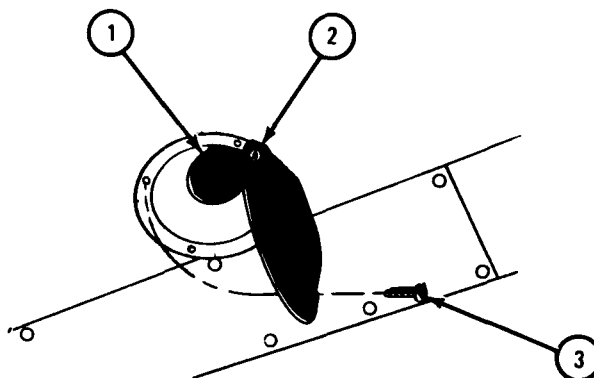
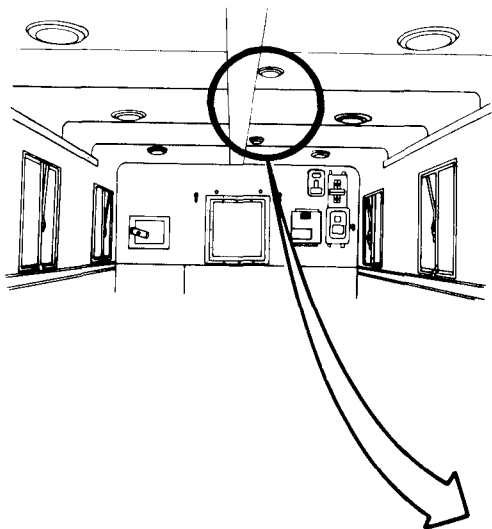

TA 047450

18-67. 115-VOLT DOME LIGHT LAMP REMOVAL AND REPLACEMENT (TRUCKS M109A2, M109A3, M185A2, AND M185A3).

NOTE

This task is the same for all dome lights.

TOOLS: Flat-tip screwdriver

SUPPLIES: None

PERSONNEL: One

EQUIPMENT CONDITION: Truck parked, engine off, handbrake set.

a. Preliminary Procedure. Turn off 115-volt circuit breaker. Refer to TM9-2320-209-10.

b. Removal.

FRAME 1

1. Using screwdriver, unscrew and take out lockscrew (1) while holding light door (2) up.
2. Open light door (2) and let it hang open.
3. Unscrew and take out 115-volt lamp (3).

END OF TASK

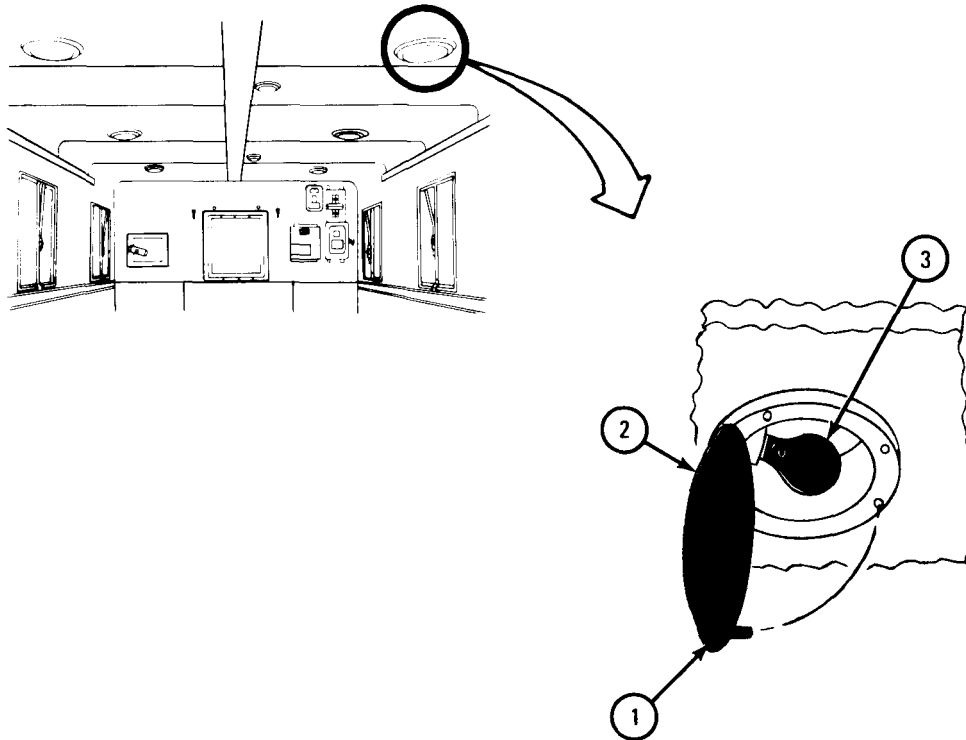

TA 047447

c. Replacement.

FRAME 1

1. Screw in and tighten 115-volt lamp (1).
2. Close light door (2).
3. Using screwdriver, screw in and tighten lock screw (3).

NOTE

Follow-on Maintenance Action Required:

Turn on 115-volt circuit breaker. Refer to TM 9-2320-209-10.

END OF TASK

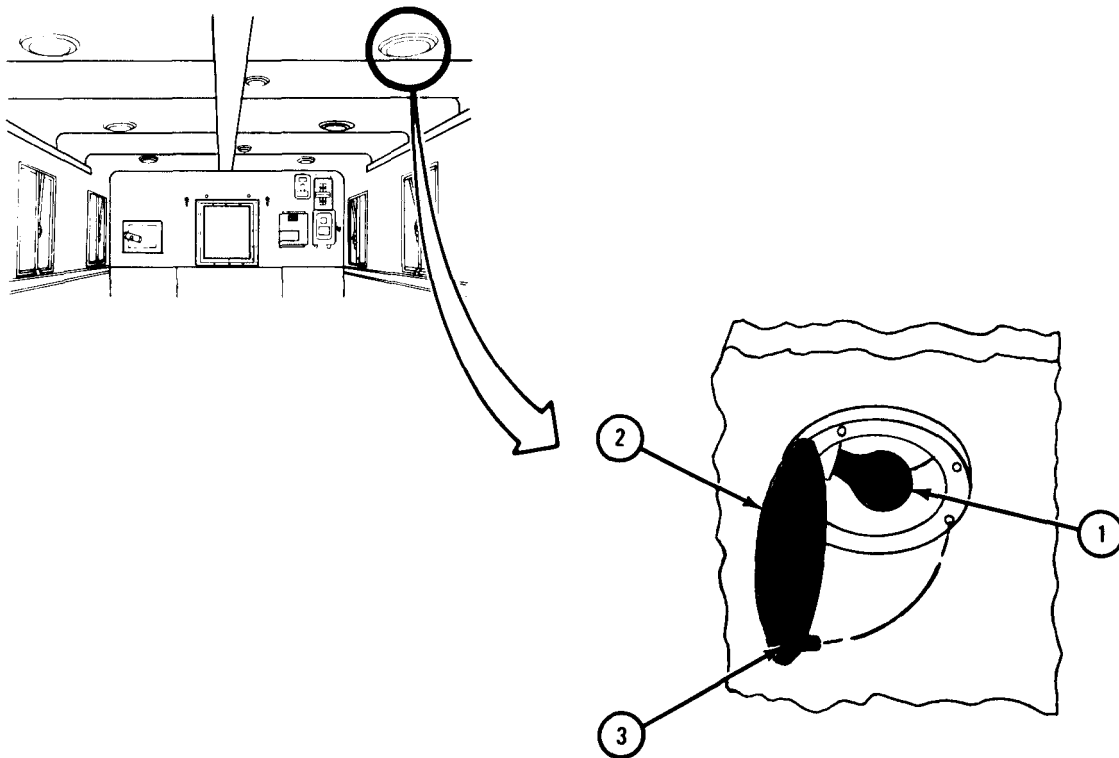

TA 047448

18-68. POWER SWITCH FUSE REMOVAL AND REPLACEMENT (TRUCKS M185A2 AND M185A3).

TOOLS: Fuse puller

SUPPLIES: Cartridge fuses, 250-volt, 60-amp (2)

PERSONNEL: One

EQUIPMENT CONDITION: Truck parked, engine off, handbrake set.

a. Preliminary Procedures.

(1) Unplug outside power plug from van receptacle. Refer to TM 9-2320-209-10.

(2) Put ladder in place and open rear door. Refer to TM 9-2320-209-10.

b. Removal.

FRAME 1

1. Working in van, pull handle (1) down to OFF position.
2. Open door (2) by pulling out right side of door.
3. Using fuse puller, take out two fuses (3).

END OF TASK

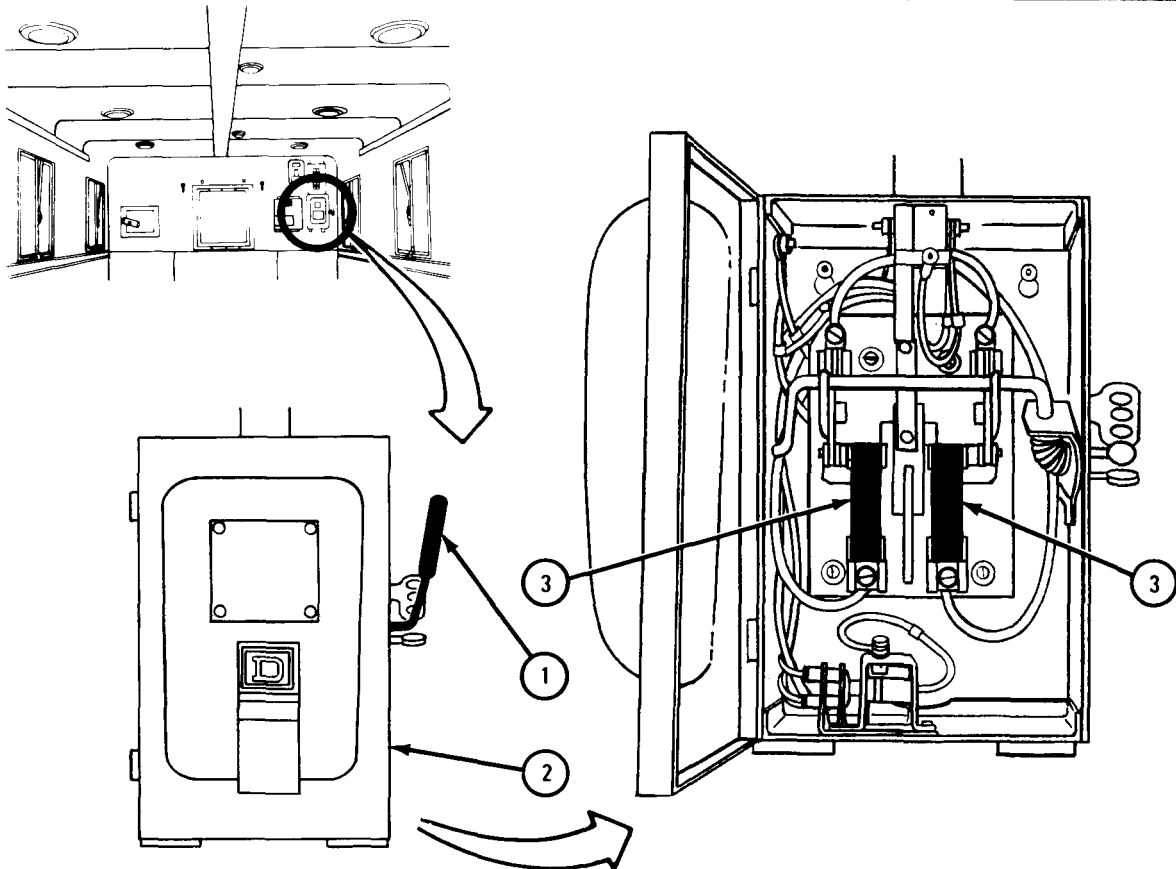

TA 083903

c. Replacement.

FRAME 1

1. Using fuse puller, put two fuses (1) into fuse clips (2).
2. Close door (3).
3. Push handle (4) up to ON position.

NOTE

Follow-on Maintenance Action Required:

1. Close rear doors and stow ladder. Refer to TM 9-2320-209-10.
2. Plug outside power plug into van receptacle. Refer to TM 9-2320-209-10.

END OF TASK

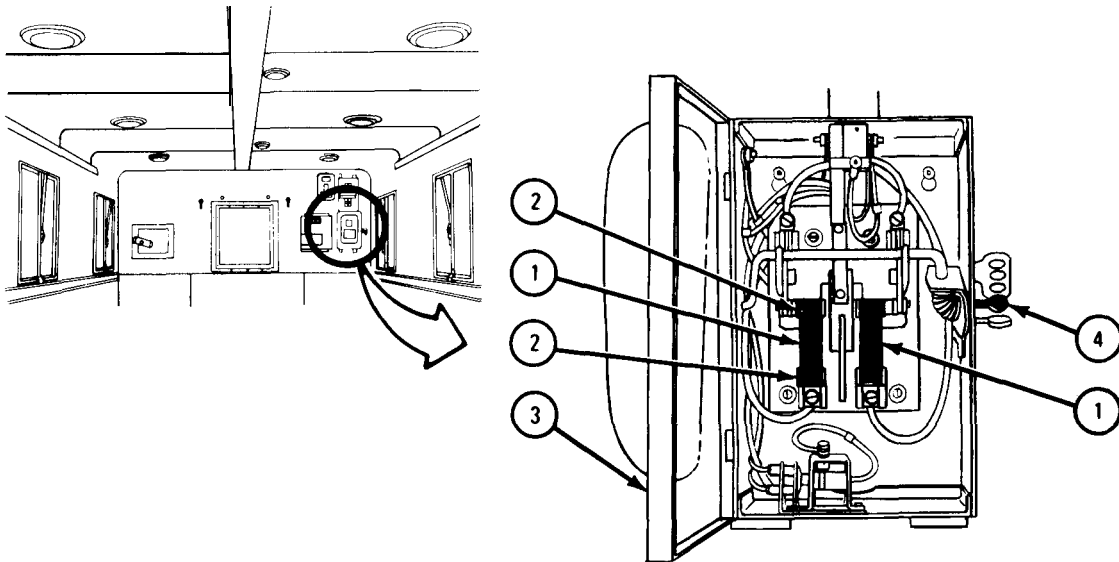

TA 083904



18-69. 24-VOLT CIRCUIT BREAKER REMOVAL AND REPLACEMENT.

TOOLS: 1 1/32-inch wrench  
Flat-tip screwdriver, 2-inch

SUPPLIES: None

PERSONNEL: One

EQUIPMENT CONDITION: Truck parked, engine off, handbrake set.

a. Preliminary Procedure. Disconnect battery ground cable. Refer to Part 1, para 7-58.

b. Removal.

FRAME 1

1. Pull off two harness connectors (1 and 2) from circuit breaker (3).
2. Using wrench and screwdriver, unscrew and take off two screws (4) and nuts (5) with washers (6). Take off circuit breaker (3).

END OF TASK

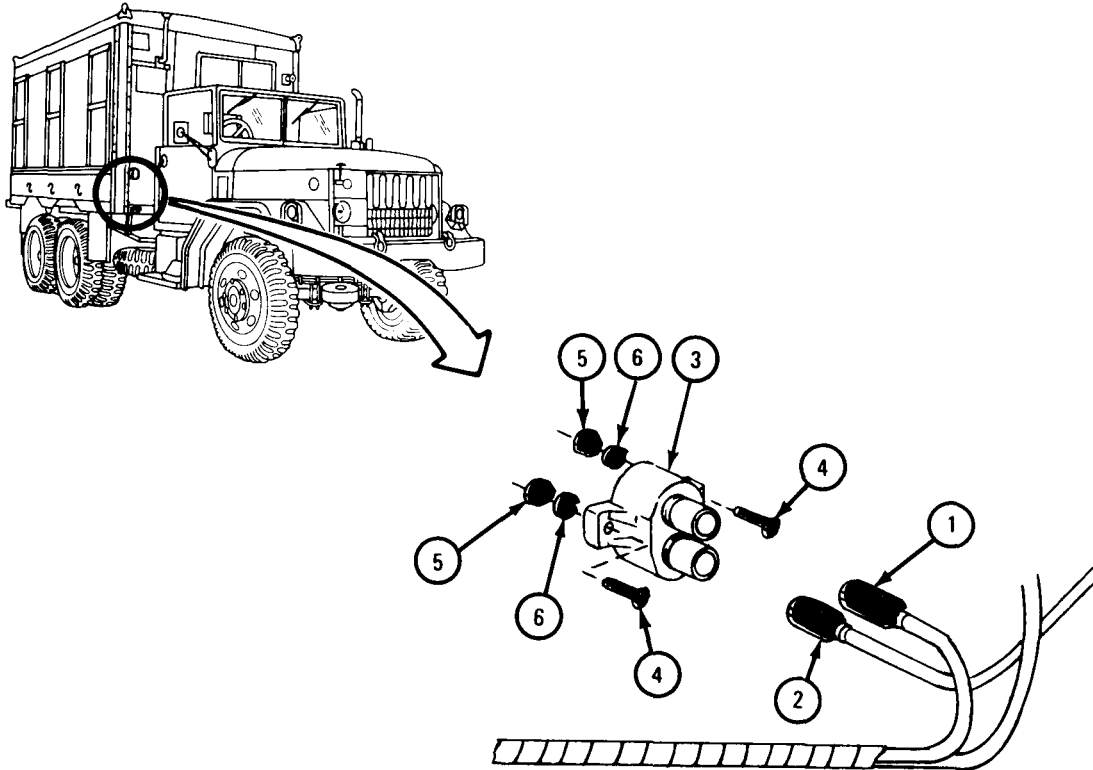

TA 047472

c. Replacement.

FRAME 1

1. Aline holes in circuit breaker (1) with holes in van body (2).
2. Using wrench and screwdriver, screw in and tighten two screws (3) and nuts (4) with washers (5).
3. Push on two connectors (6 and 7).

NOTE

Follow-on Maintenance Action Required:

Reconnect battery ground cable. Refer to Part 1, para 7-58.

END OF TASK

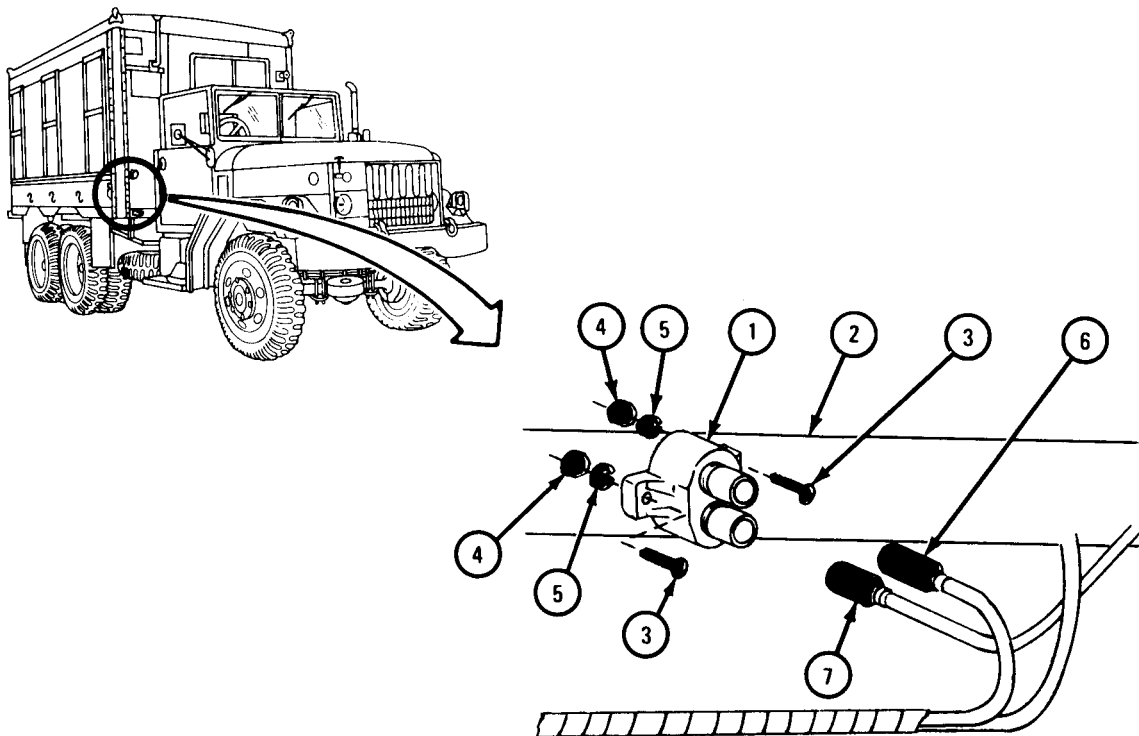

TA 047473

## 18-70. 115-VOLT CIRCUIT BREAKER REMOVAL AND REPLACEMENT.

TOOLS: Flat-tip screwdriver

SUPPLIES: None

PERSONNEL: One

EQUIPMENT CONDITION: Truck parked, engine off, handbrake set.

a. Removal.WARNING

Before working on circuit breaker box, take off 115-volt power cable to stop injury from electrical shock. Refer to TM 9-2320-209-10.

## FRAME 1

1. Using screwdriver, unscrew and take off four screws (1).
2. Take off circuit breaker box cover (2) .

GO TO FRAME 2

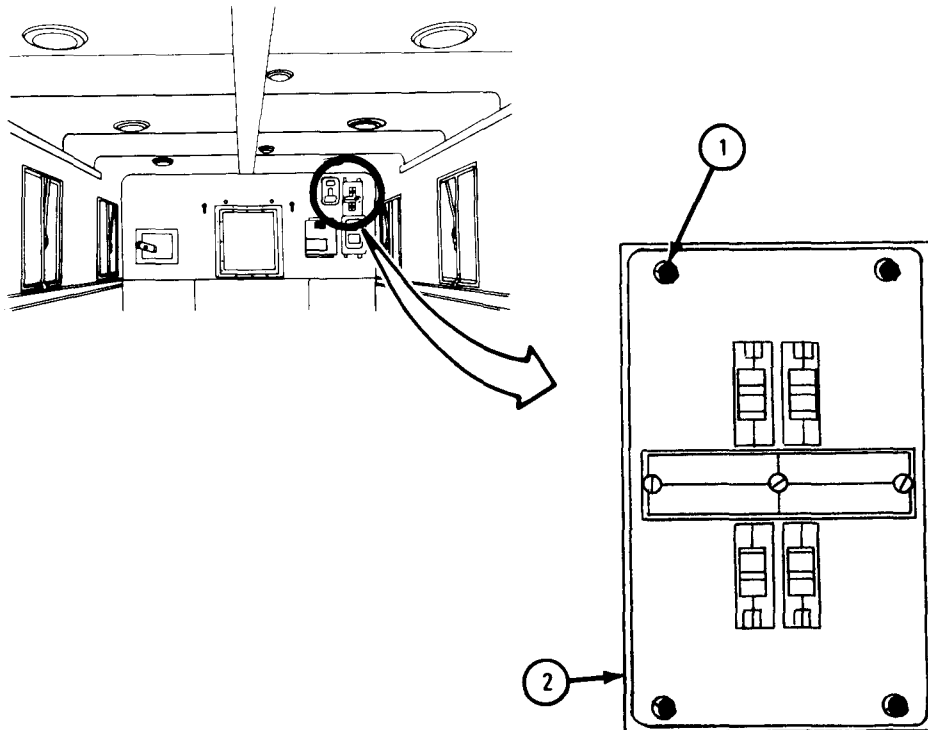

TA 047468

FRAME 2

1. Tilt top of circuit breaker (1) out and down. Take it out of mounting bracket (2).
2. Using flat-tip screwdriver, loosen screw (3) and take wire (4) out of circuit breaker (1).

END OF TASK

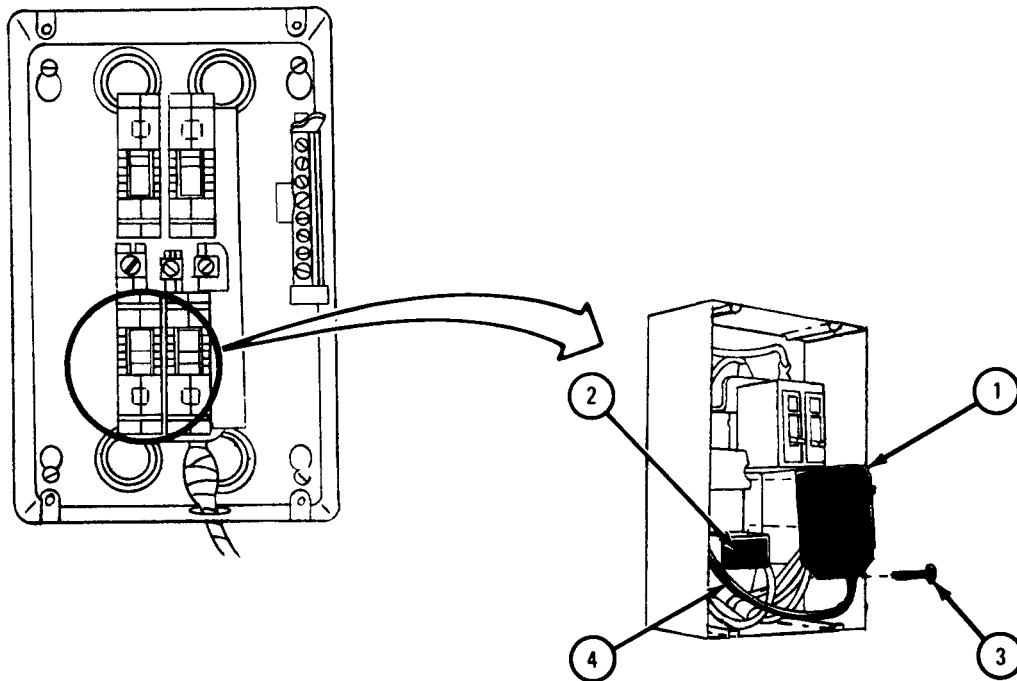

TA 047469

b. Replacement.

FRAME 1

1. Hold circuit breaker (1) up to mounting bracket (2).
  2. Put wire (3) into bottom of circuit breaker (1) and using flat-tip screwdriver, tighten screw (4).
  3. Put bottom of circuit breaker (1) into mounting bracket (2) and push in top.
- GO TO FRAME 2

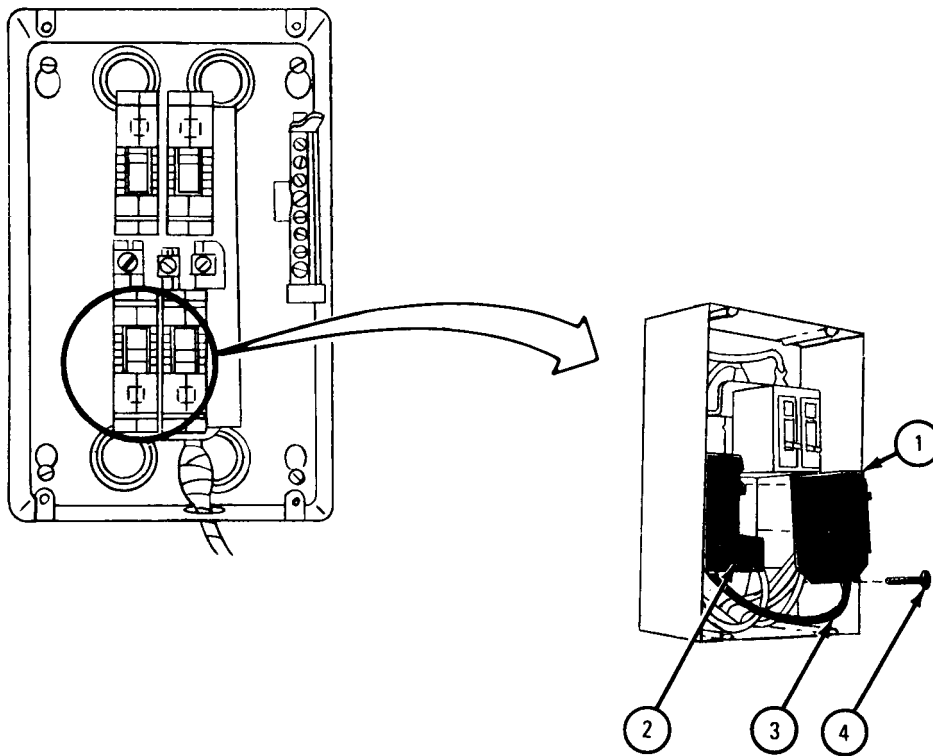

TA 047470

FRAME 2

1. Put on circuit breaker box cover (1).
2. Using screwdriver, screw in and tighten four screws (2).

NOTE

Follow-on Maintenance Action Required:

Replace 115-volt power cable. Refer to TM 9-2320-209-10.

END OF TASK

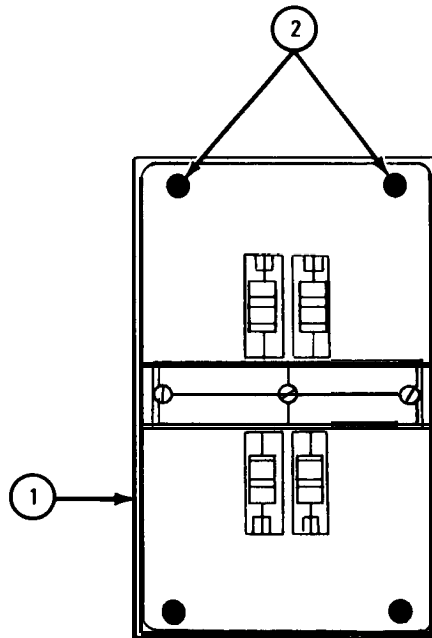

TA 047471

18-71. 115-VOLT DOME LIGHT SWITCH REMOVAL AND REPLACEMENT.

TOOLS: Flat-tip screwdriver  
 7/16-inch socket wrench  
 Light ballpeen hammer  
 Punch  
 3-inch extension  
 Ratchet  
 7/16-inch wrench

SUPPLIES: Tags

PERSONNEL: One

EQUIPMENT CONDITION: Truck parked, engine off, handbrake set.

a. Preliminary Procedures.

(1) Disconnect battery ground cable. Refer to Part 1, para 7-58.

(2) Disconnect main plug from receptacle outside van. Refer to TM 9-2320-209-10.

(3) Turn off main power switch. Refer to TM 9-2320-209-10.

(4) Turn off all circuit breakers. Refer to TM 9-2320-209-10.

b. Removal.

FRAME 1

1. Using screwdriver, unscrew and take out two screws (1).
2. Pull cover (2) away from box (3) and turn cover around.

GO TO FRAME 2

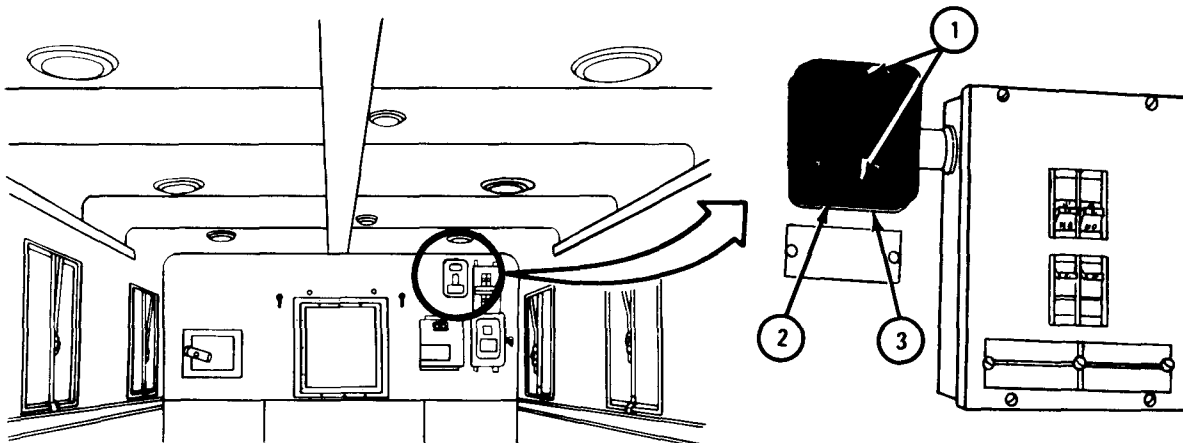

TA 083282

FRAME 2

1. Hold cover (1) as shown.
2. Put five wires (2) in place as tagged and, using screwdriver, screw in and tighten four screws (3). Take off tags.

GO TO FRAME 3

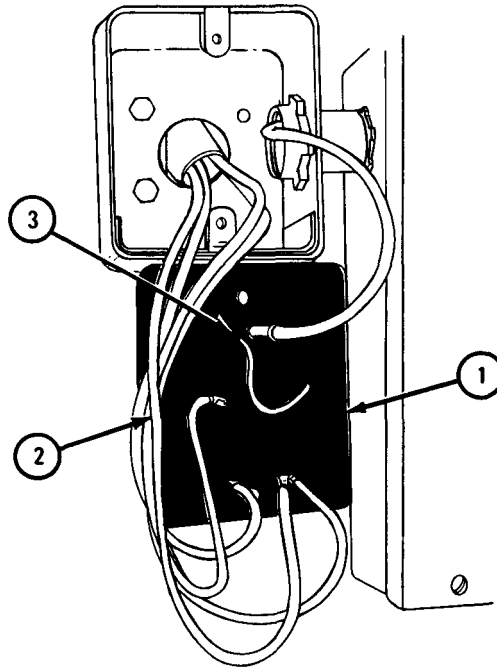

TA 083285



c. Replacement.

## FRAME 1

1. Hold box (1) up near wall (2) and pull four wires (3) through hole in rear of box . Pull wire (4) through hole in side of box.
2. Hold box (1) in place on wall (2) with conduit nipple (5) in hole in side of box and align screw holes.
3. Using ratchet, extension, socket wrench, and 7/16-inch wrench, screw in and tighten two screws (6) and two nuts (7).
4. Screw bushing and conduit locknut (8) on conduit nipple (5) as shown.
5. Using hammer and punch, tighten conduit locknut (8).

GO TO FRAME 2

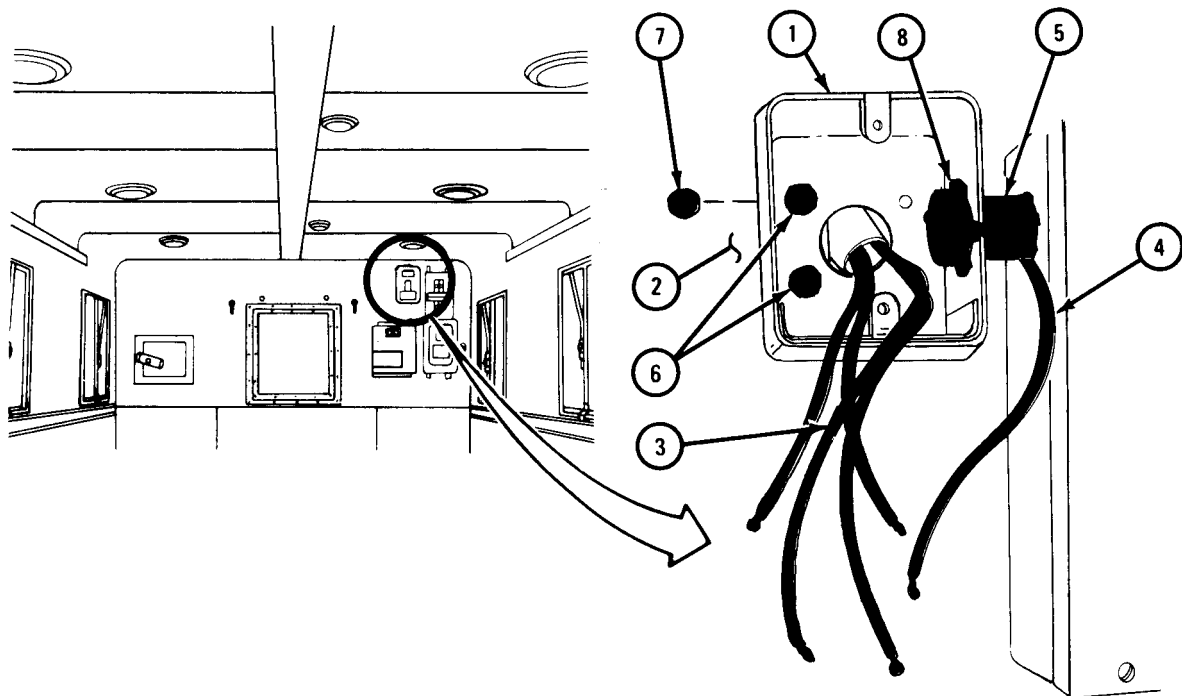

TA 083284

FRAME 2

NOTE

Tag all wires before taking them off so they will be put back in the same places.

1. Using screwdriver, unscrew and take out four screws (1). Take off cover (2).
2. Using hammer and punch, unscrew and take off bushing and conduit locknut (3).
3. Using ratchet, extension, socket wrench, and 7/16-inch wrench, unscrew and take out two screws (4) and two nuts (5). Take off box (6).

END OF TASK

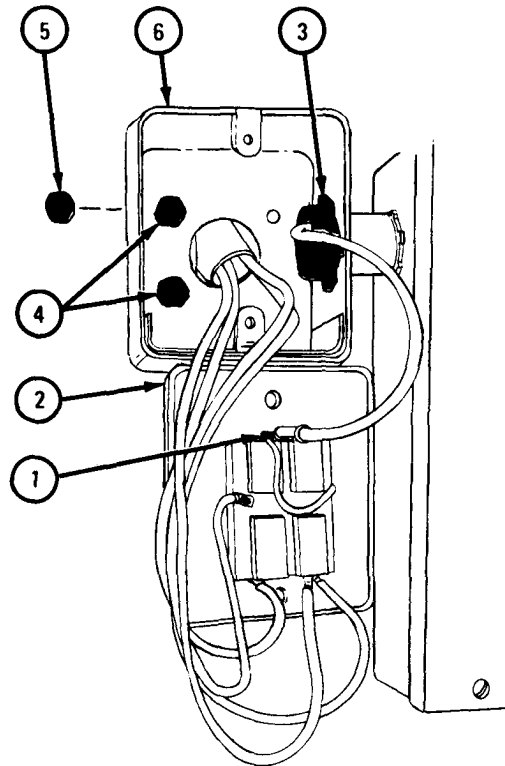

TA 083283

## FRAME 3

1. Put cover (1) in place as shown.
2. Using screwdriver, screw in and tighten two screws (2).

## NOTE

## Follow-on Maintenance Action Required:

1. Turn on all circuit breakers. Refer to TM 9-2320-209-10.
2. Turn on main power switch. Refer to TM 9-2320-209-10.
3. Connect main plug to receptacle outside van. Refer to TM 9-2320-209-10.
4. Reconnect battery ground cable. Refer to Part 1, para 7-58.

END OF TASK

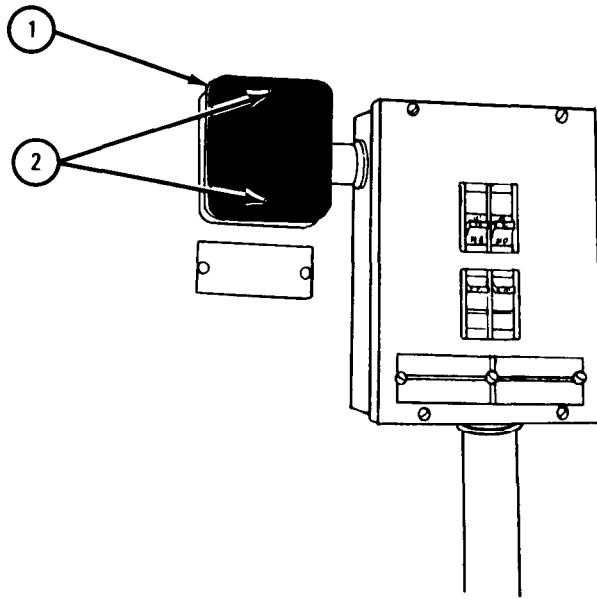

TA 083286

18-72. 24-VOLT DOME LIGHT AND BLACKOUT DOME LIGHT TOGGLE SWITCHES  
REMOVAL AND REPLACEMENT (TRUCK M109A2 AND M109A3).

TOOLS: Flat-tip screwdriver  
9/16-inch wrench

SUPPLIES: Tags

PERSONNEL: One

EQUIPMENT CONDITION: Truck parked, engine off, handbrake set.

a. Preliminary Procedure. Disconnect battery ground cable. Refer to Part 1, para 7-58.

b. Removal.

(1) Dome light switch.

FRAME 1

## NOTE

Tag all electrical connections so they can be put back in the same places.

1. Using screwdriver, unscrew and take out four screws (1).
2. Pull switchplate (2) away from wall.
3. Working in back on switchplate (2), unscrew and take out screws (3 and 4).
- Take off wires (5 and 6).

GO TO FRAME 2

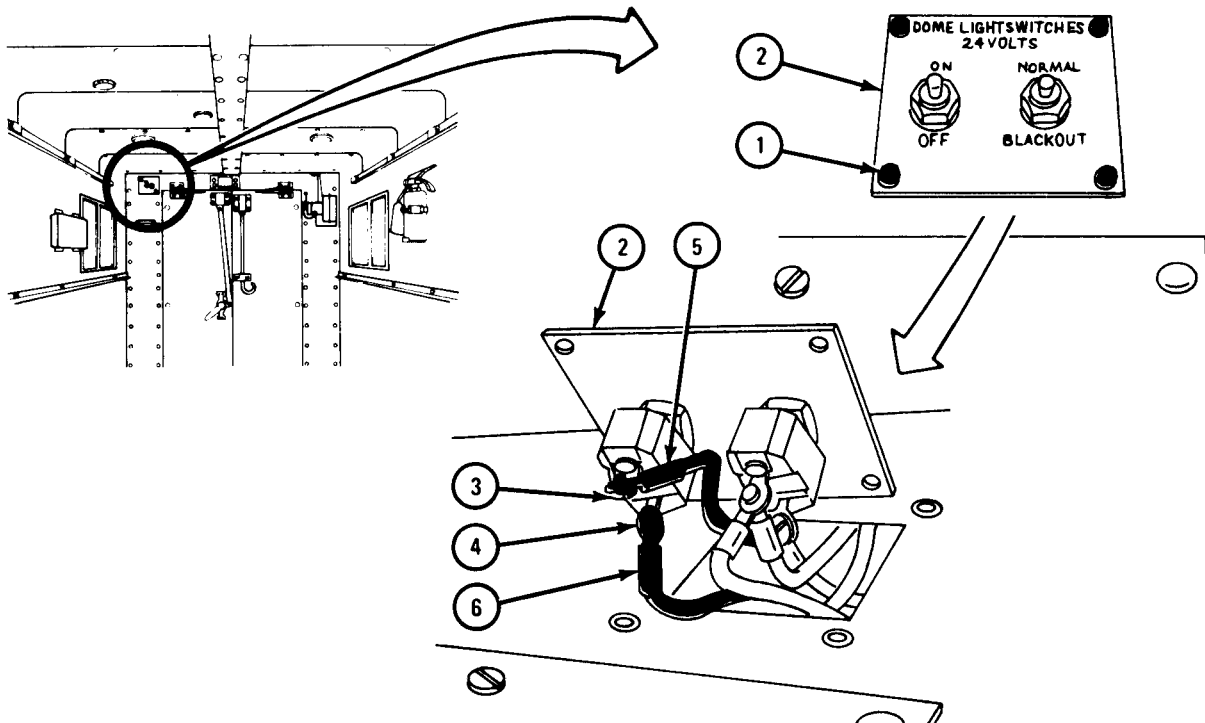

TA 047596

FRAME 2

1. Using 9/16-inch wrench, unscrew and take off nut (1) and washer (2).
2. Take out switch (3) from switchplate (4).

END OF TASK

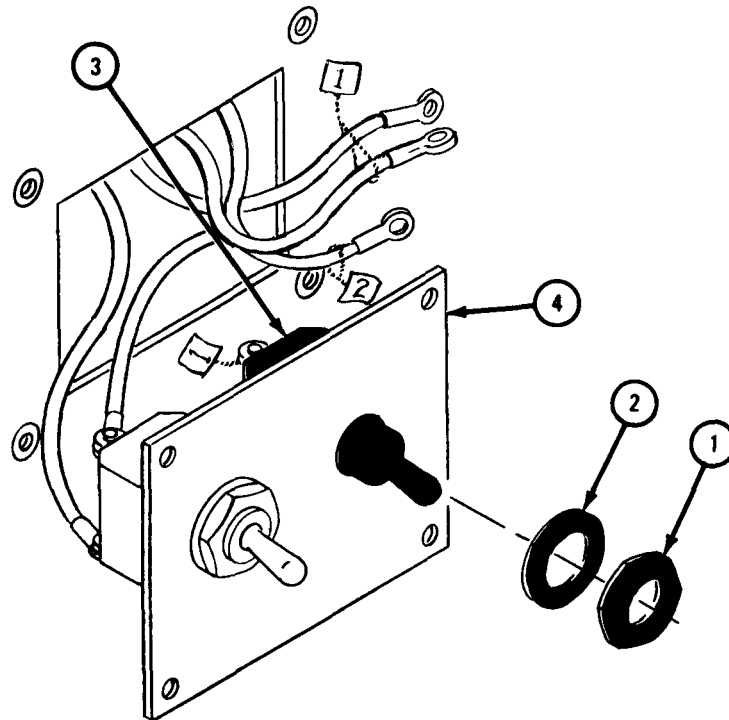

TA 047506

(2) Dome light blackout switch.

FRAME 1

NOTE

Tag all electrical connections so they can be put back in the same places.

1. Using screwdriver, unscrew and take out four screws (1).
2. Pull switchplate (2) away from wall.
3. Using screwdriver, unscrew and take out screw (3). Take off wires (4 and 5).
4. Using screwdriver, unscrew and take out screw (6). Take off wires (7 and 8).

GO TO FRAME 2

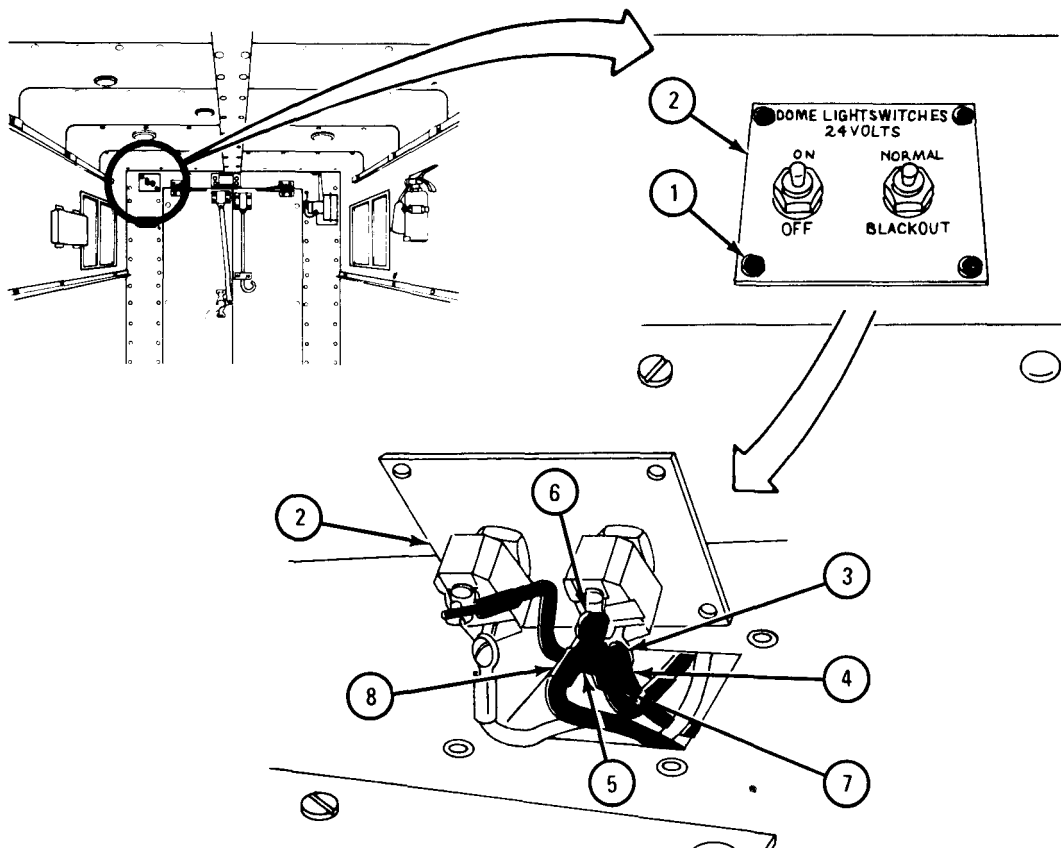

TA 047600

FRAME 2

1. Working in front of switchplate (1) and using 9/16-inch wrench, unscrew and take off nut (2) and washer (3).
2. Pull out switch (4) from back of switchplate (1).

END OF TASK

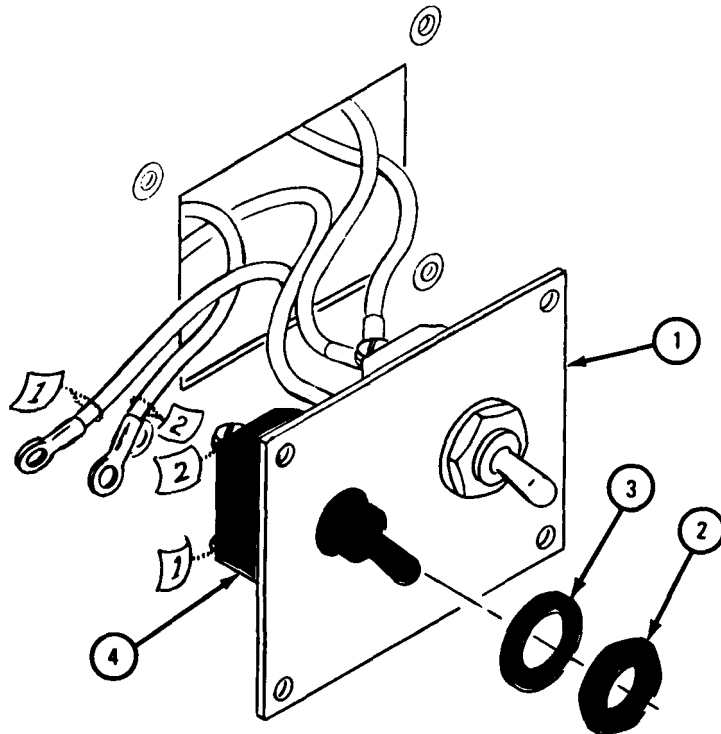

TA 047597



c. Replacement.

(1) Dome light switch.

## FRAME 1

1. Put switch (1) into switchplate (2).
2. Working in front of switchplate (2) using 9/16-inch wrench, screw on and tighten washer (3) and nut (4).

GO TO FRAME 2

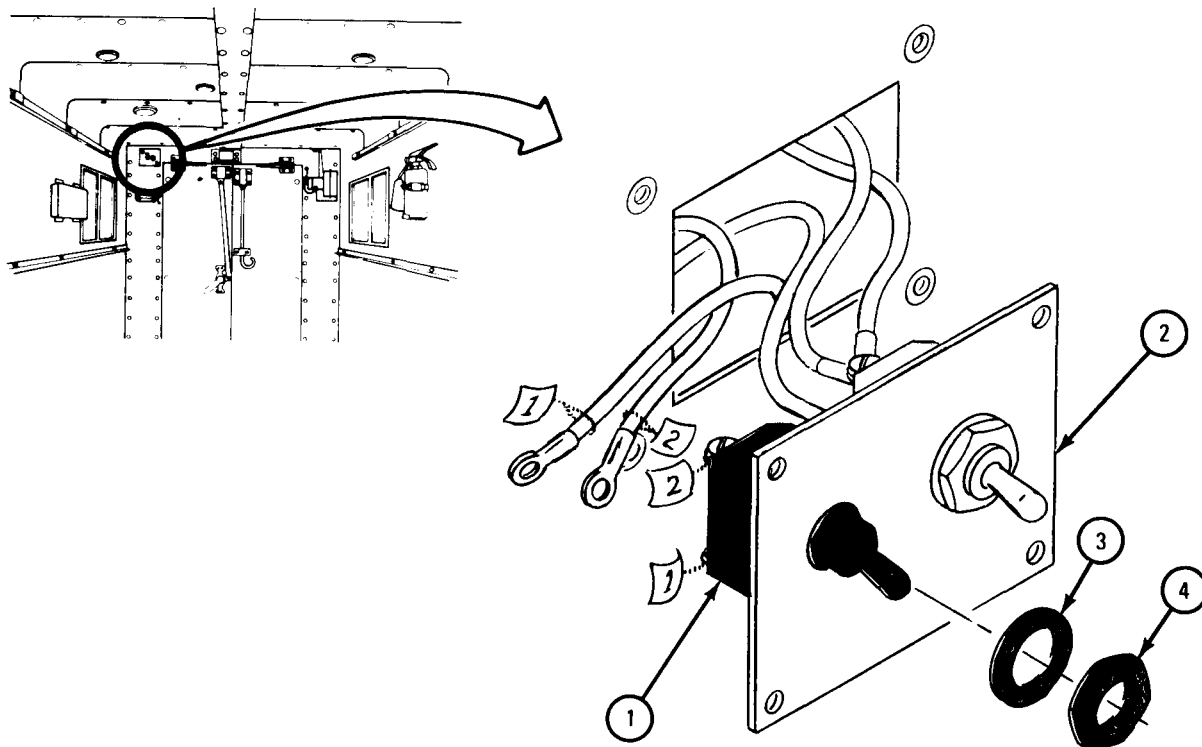

TA 047598

FRAME 2

1. Working in back of switchplate (1) put wires (2 and 3) in place as tagged. Using screwdriver, screw in and tighten screws (4 and 5). Take off tags.
2. Put switchplate (1) on wall and aline mounting holes. Using screwdriver, screw in and tighten four screws (6).

NOTE

Follow-on Maintenance Action Required:

Reconnect battery ground cable. Refer to Part 1, para 7-58.

END OF TASK

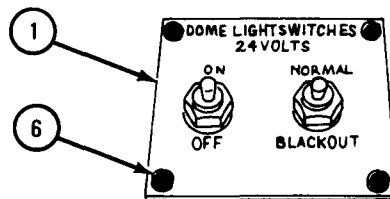
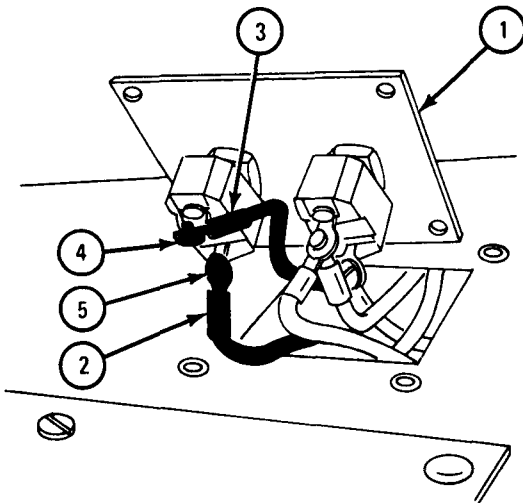

TA 047599

(2) Dome light blackout switch.

FRAME 1

1. Put switch (1) into switchplate (2).
  2. Using 9/16-inch wrench, screw on and tighten washer (3) and nut (4).
- GO TO FRAME 2

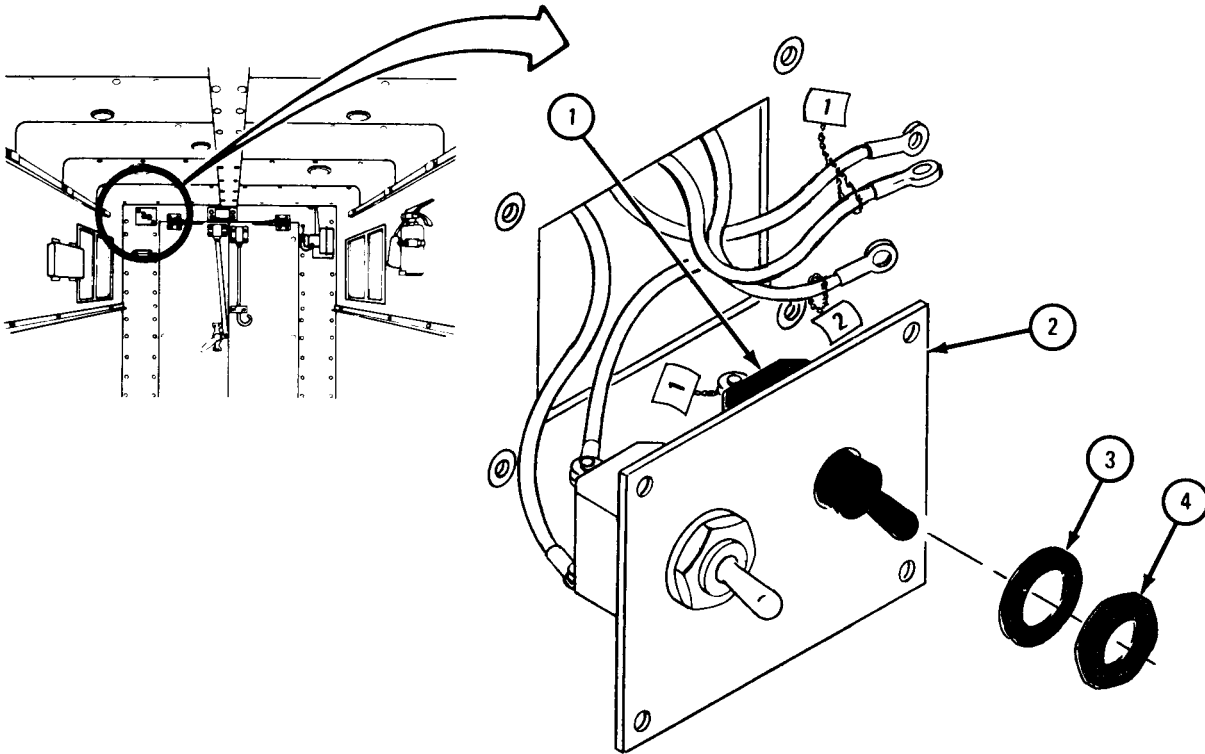

TA 047507

FRAME 2

1. Put wires (1 and 2) in place as tagged. Using screwdriver, screw in and tighten screw (3). Take off tags.
2. Put wires (4 and 5) in place as tagged. Using screwdriver, screw in and tighten screw (6). Take off tags.
3. Put switchplate (7) on wall and align mounting holes. Using screwdriver, screw in and tighten four screws (8).

NOTE

Follow-on Maintenance Action Required:

Reconnect battery ground cable. Refer to Part 1, para 7-58.

END OF TASK

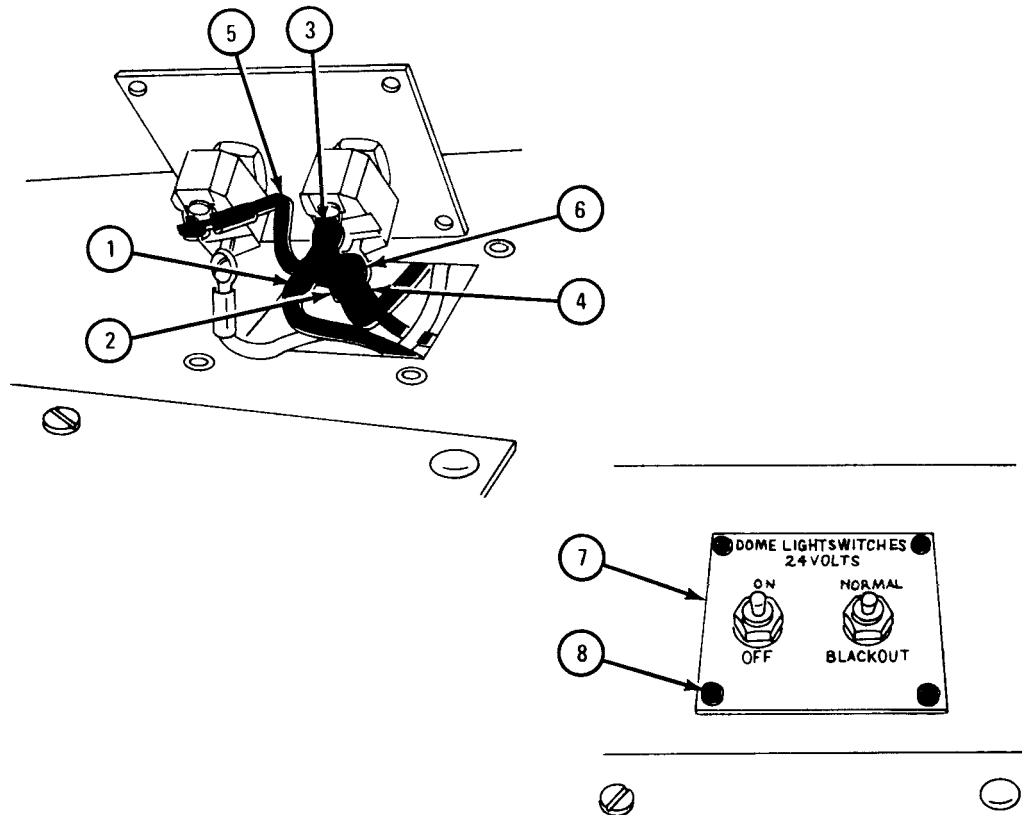

TA 047508

18-73. 24-VOLT AND 115-VOLT VAN REAR DOOR BLACKOUT SWITCHES REMOVAL AND REPLACEMENT.

TOOLS: Flat-tip screwdriver  
9/16-inch wrench (2)

SUPPLIES: Tags

PERSONNEL: One

EQUIPMENT CONDITION: Truck parked, engine off, handbrake set.

a. Preliminary Procedures.

(1) Disconnect external power cables. Refer to TM 9-2320-209-10.

(2) Disconnect battery ground cable. Refer to Part 1, para 7-58.

b. Removal.

FRAME 1

1. Using screwdriver, unscrew and take off four screws (1).

2. Take off cover (2).

GO TO FRAME 2

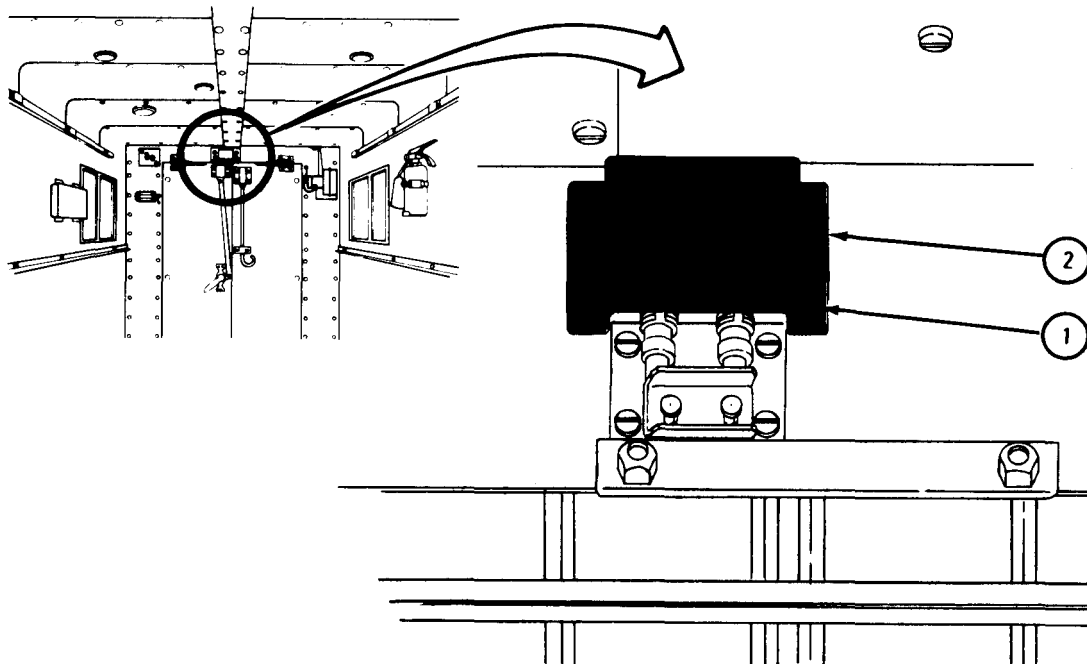

TA 083360

FRAME 2

NOTE

Tag all wires so they can be put back in the same places.

1. Using two wrenches, unscrew and take off two nuts (1). Take two switches (2) out of bracket (3).
2. Using screwdriver, unscrew four screws (4) and take four wires (5) off two switches (2).
3. Unscrew and take off two nuts (6), one from each switch (2).

END OF TASK

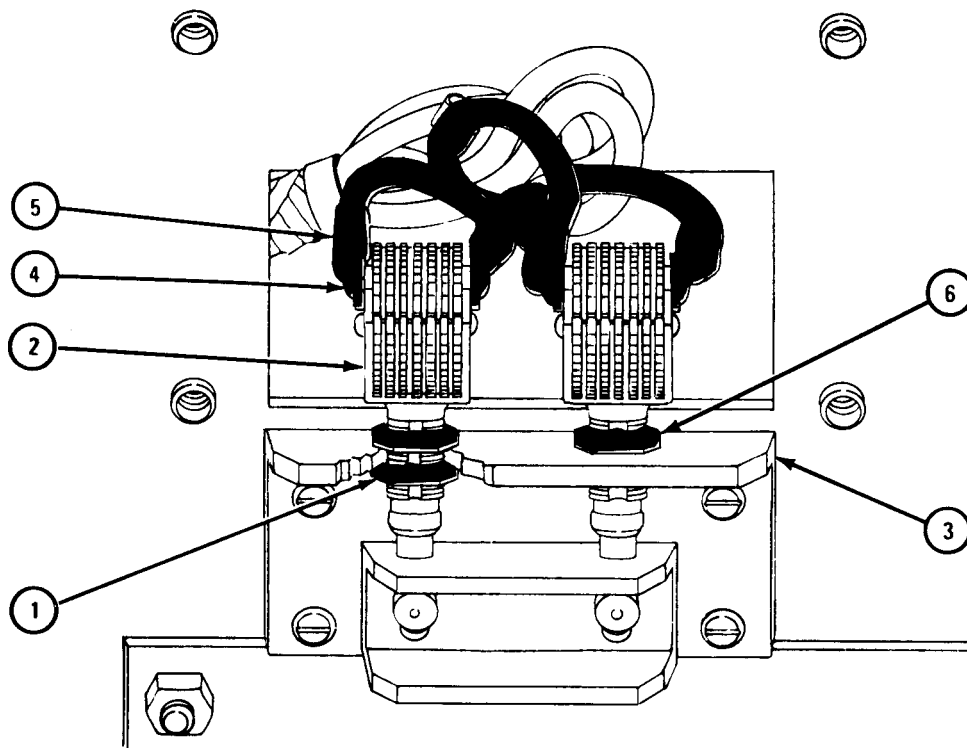

TA 083361

c. Replacement.

## FRAME 1

1. Put four wires (1) in place as tagged. Using screwdriver, screw on and tighten four screws (2). Take off tags.
2. Screw two nuts (3) on switches (4), and put switches in place through holes in bracket (5).
3. Using wrenches, tighten two nuts (6).

GO TO FRAME 2

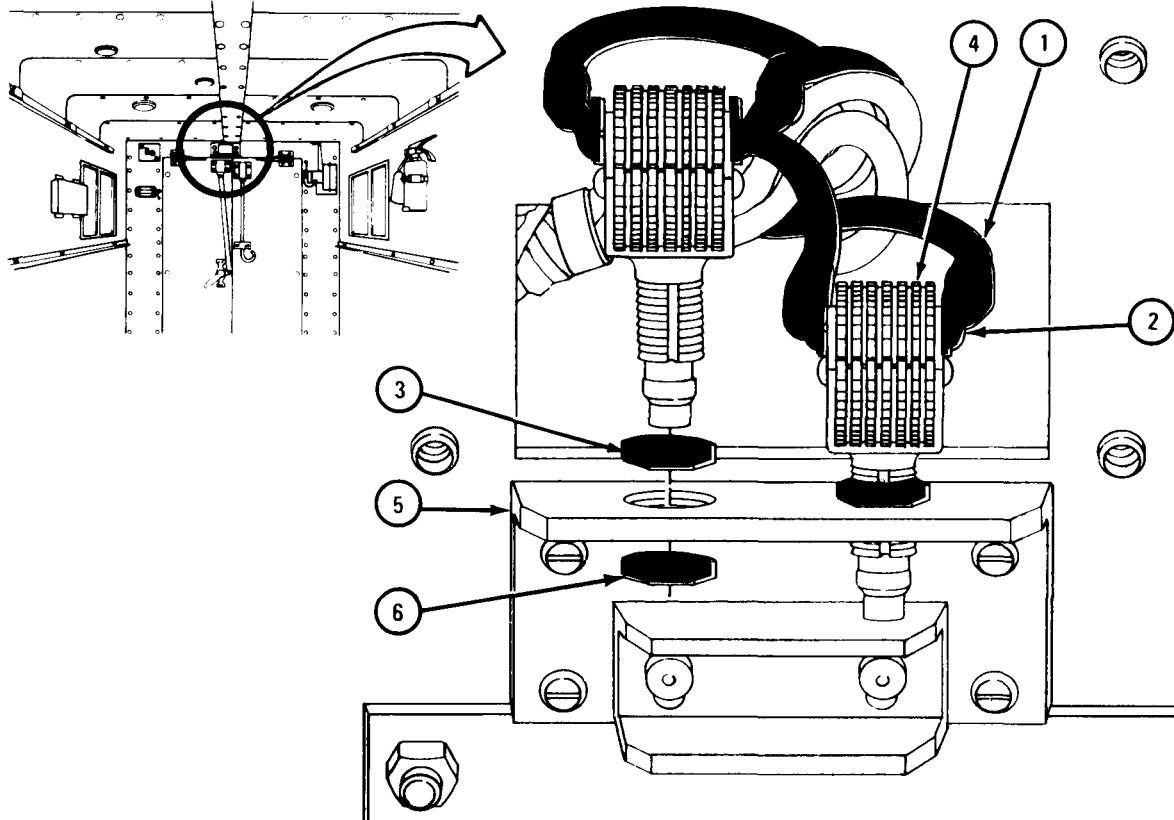

TA 083362

FRAME 2

1. Put cover (1) in place and aline holes.
2. Using screwdriver, screw on and tighten four screws (2).

NOTE

Follow-on Maintenance Action Required:

1. Replace external power cables. Refer to TM 9-2320-209-10.
2. Reconnect battery ground cable. Refer to para 7-58.

END OF TASK

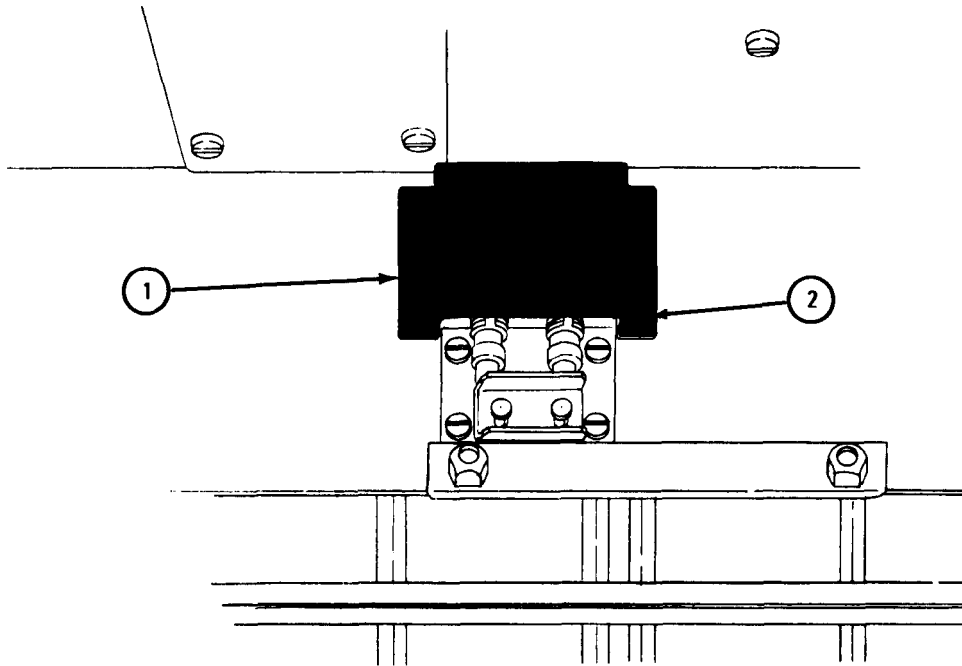

TA 083363



## 18-74. EXHAUST BLOWER ASSEMBLY REMOVAL AND REPLACEMENT (TRUCKS M109A2 AND M109A3).

TOOLS: Flat-tip screwdriver

SUPPLIES: None

PERSONNEL: One

EQUIPMENT CONDITION: Truck parked, engine off, handbrake set.

a. Removal.

## FRAME 1

1. Unplug blower motor cable connector (1) from receptacle (2).
  2. Using screwdriver, unscrew and take out two screws (3).
- GO TO FRAME 2

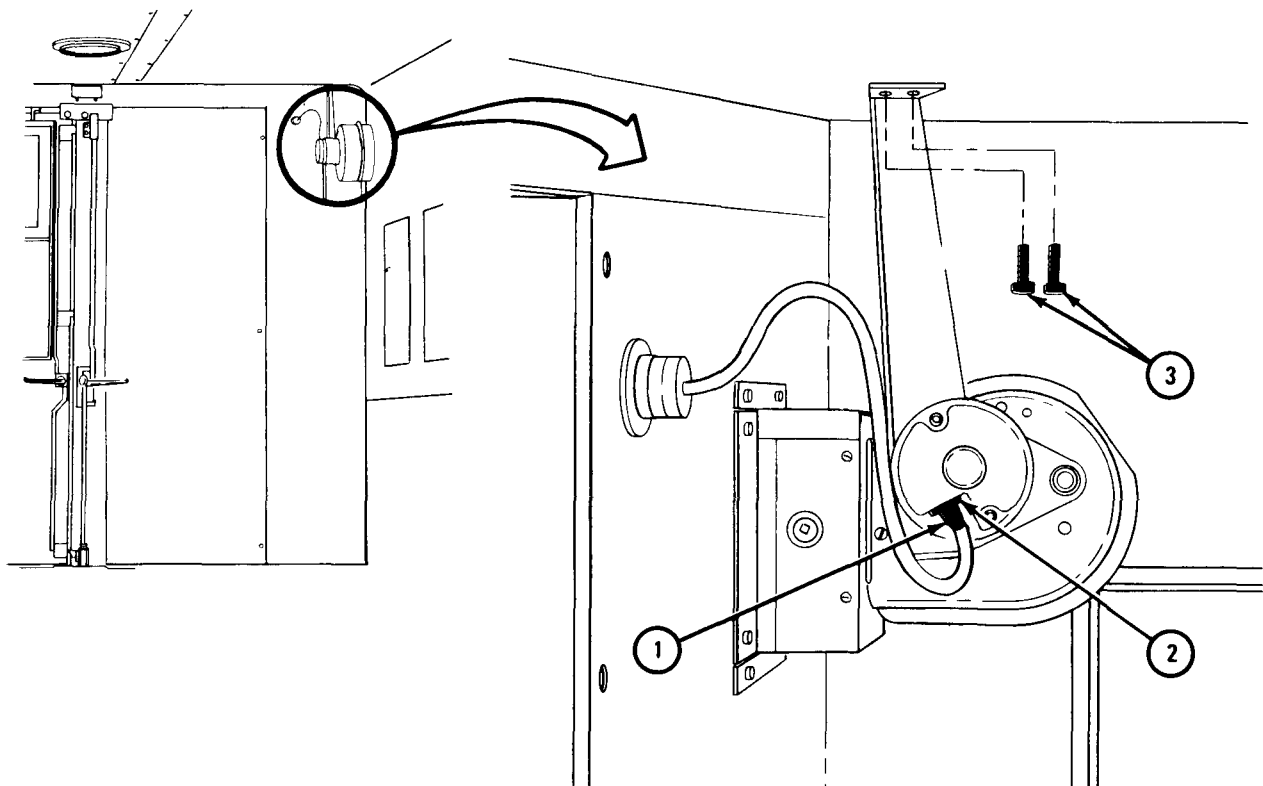

TA 047500

FRAME 2

1. Hold exhaust blower assembly (1) and using screwdriver, unscrew and take out six screws (2).

2. Take off exhaust blower assembly (1).

END OF TASK

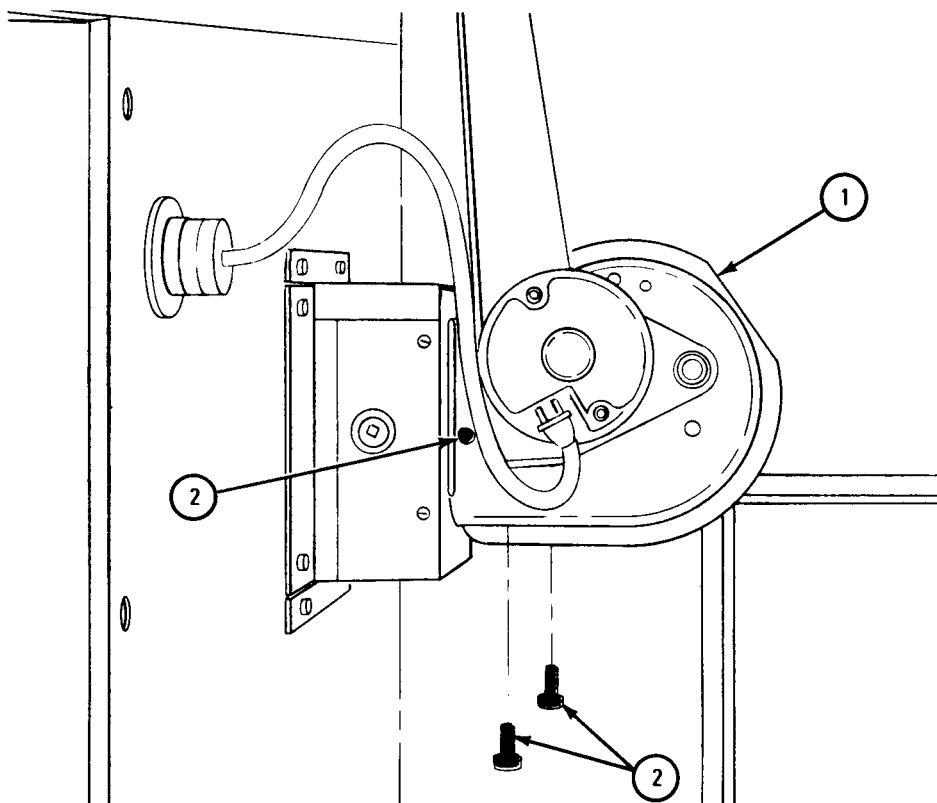

TA 101564

b. Replacement.

## FRAME 1

1. Put exhaust blower assembly (1) in place, lining up holes.
2. Using screwdriver, screw in and tighten two screws (2).

GO TO FRAME 2

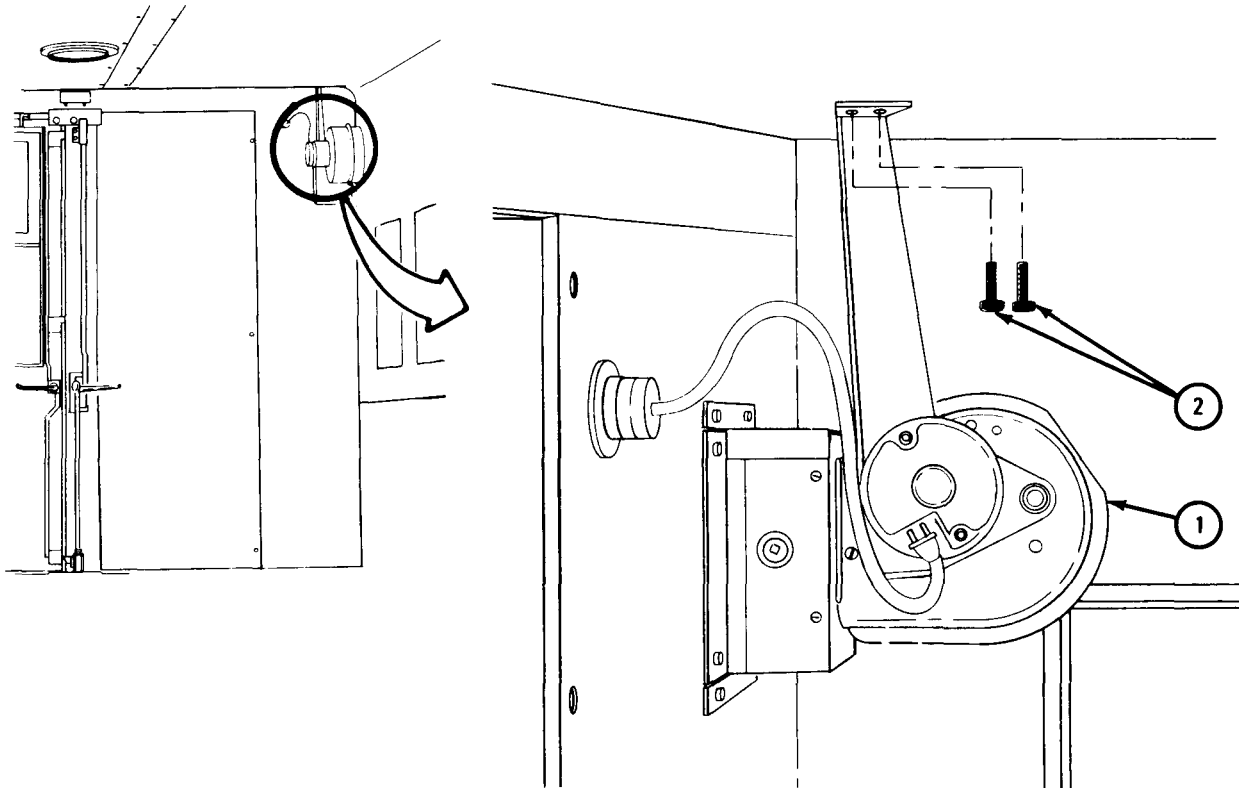

TA 047501

FRAME 2

1. Using screwdriver, screw in and tighten six screws (1).
2. Plug cable connector (2) into receptacle (3).

END OF TASK

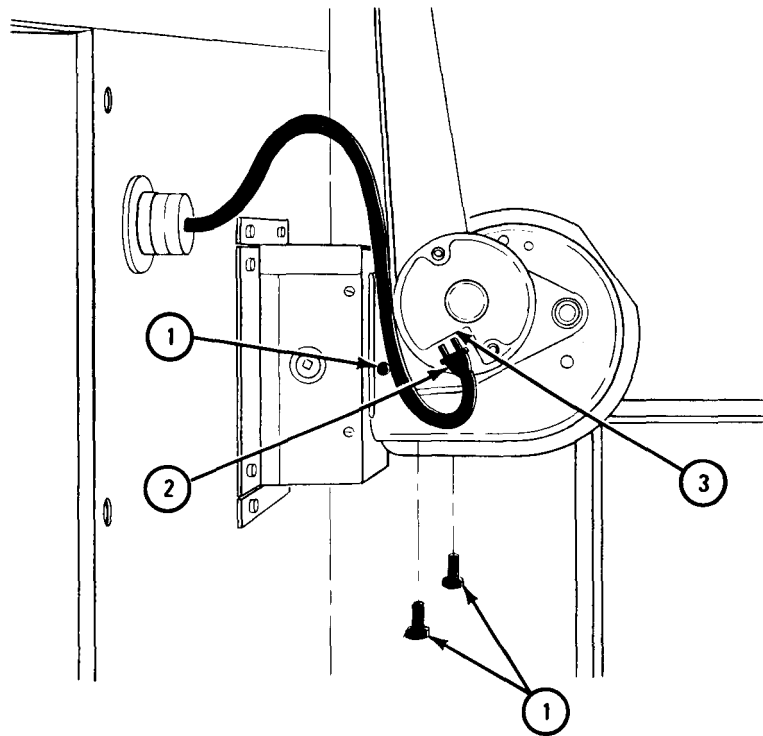

TA 101565

18-75. VAN DOOR ASSEMBLY REMOVAL AND REPLACEMENT (TRUCKS M109A2, M109A3, M185A2, AND M185A3).

NOTE

This task is the same for the right and left rear van door assemblies. This task is shown for the right rear van door.

TOOLS:	3/8-inch drive socket wrench set	Flat-tip screwdriver
	1/2-inch wrench	1/2-inch socket wrench
	Hoist sling	6-inch extension
	Hoist equipment, 2-ton capacity	10-foot stepladder

SUPPLIES: None

PERSONNEL: One

EQUIPMENT CONDITION: Truck parked, engine off, handbrake set.

Preliminary Procedure. If left rear door is being taken off, remove ladder. Refer to TM 9-2320-209-10.

b. Removal.

FRAME 1

1. Working inside truck, using screwdriver, unscrew and take out two screws (1). Pull door check (2) away from door (3). Open door partway.

GO TO FRAME 2

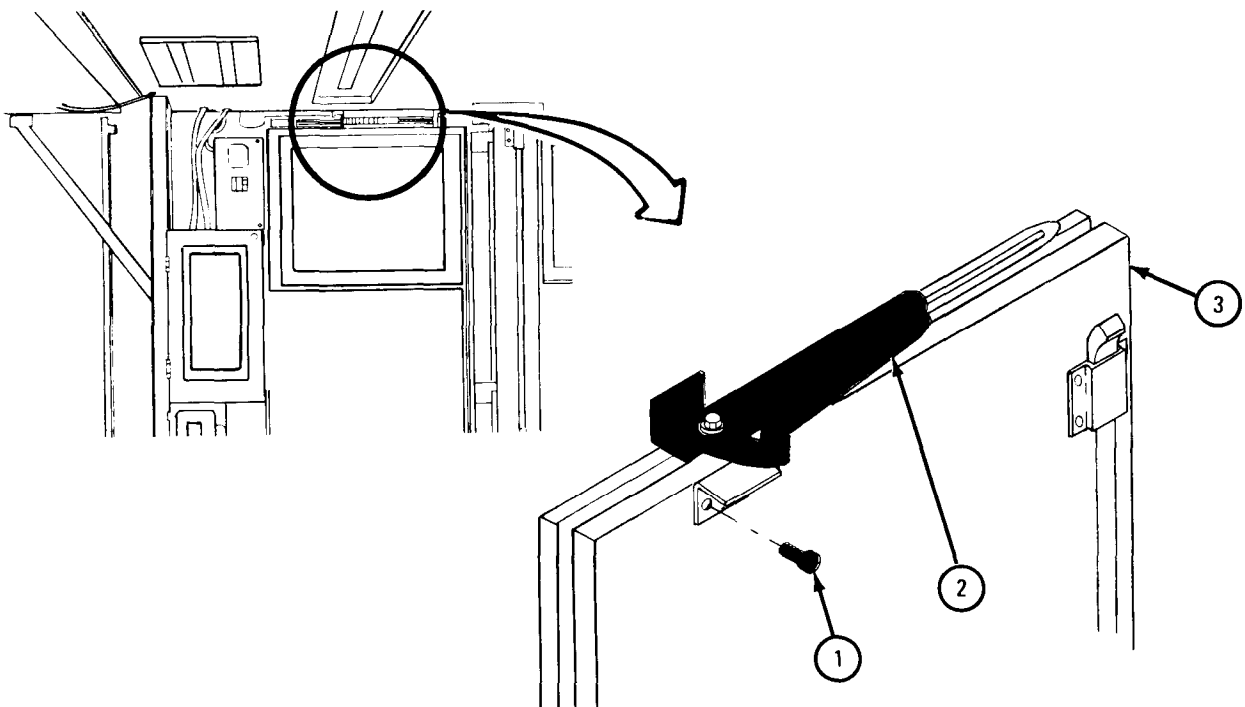

TA 047532

FRAME 2

WARNING

Be careful to hold van door up with hoist equipment.  
Van door is heavy and may fall and injure personnel.

1. Put hoist sling (1) on van door (2) and join equipment to hoist sling (3).
2. Working on outside of door (2), using 1/2-inch socket wrench, unscrew and take off two capscrews (4) and lockwashers (5) from end door hinges (6 and 7). Unscrew and take off two capscrews (8) and lockwashers (9) from center door hinge (10).

GO TO FRAME 3

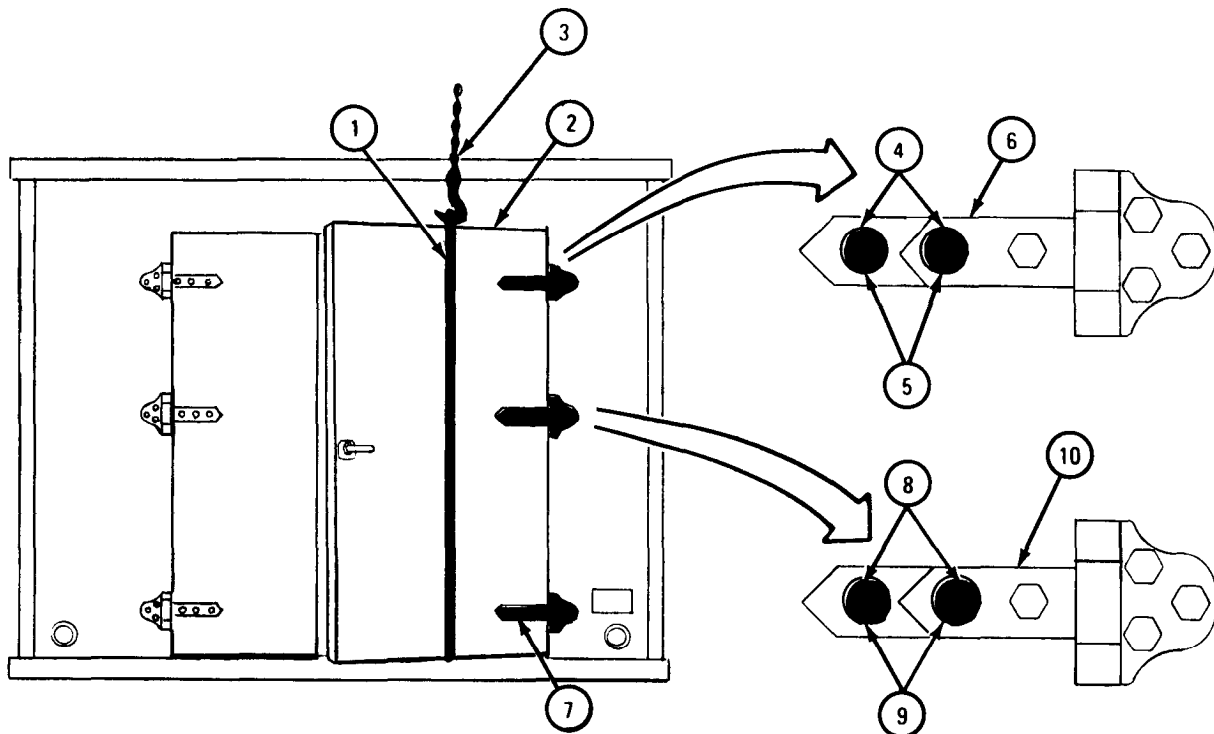

TA 047533

FRAME 3

- Soldier A 1. Working on outside door (1) using 1/2-inch wrench, hold capscrew (2) and tell soldier B when ready.
- Soldier B 2. Working on inside of door (1) using 1/2-inch socket wrench, unscrew and take off locknut (3) through access hole (4).
- Soldier A 3. Take out capscrew (2) and washer (5).
- Soldiers A and B 4. Do steps 1 and 2 again for hinges (6 and 7) on center and bottom of door (1).
- Soldier B 5. Guide door (1) while it is lowered to ground.
- Soldier A 6. Using hoist equipment (8), lower door (1) to ground.
- END OF TASK

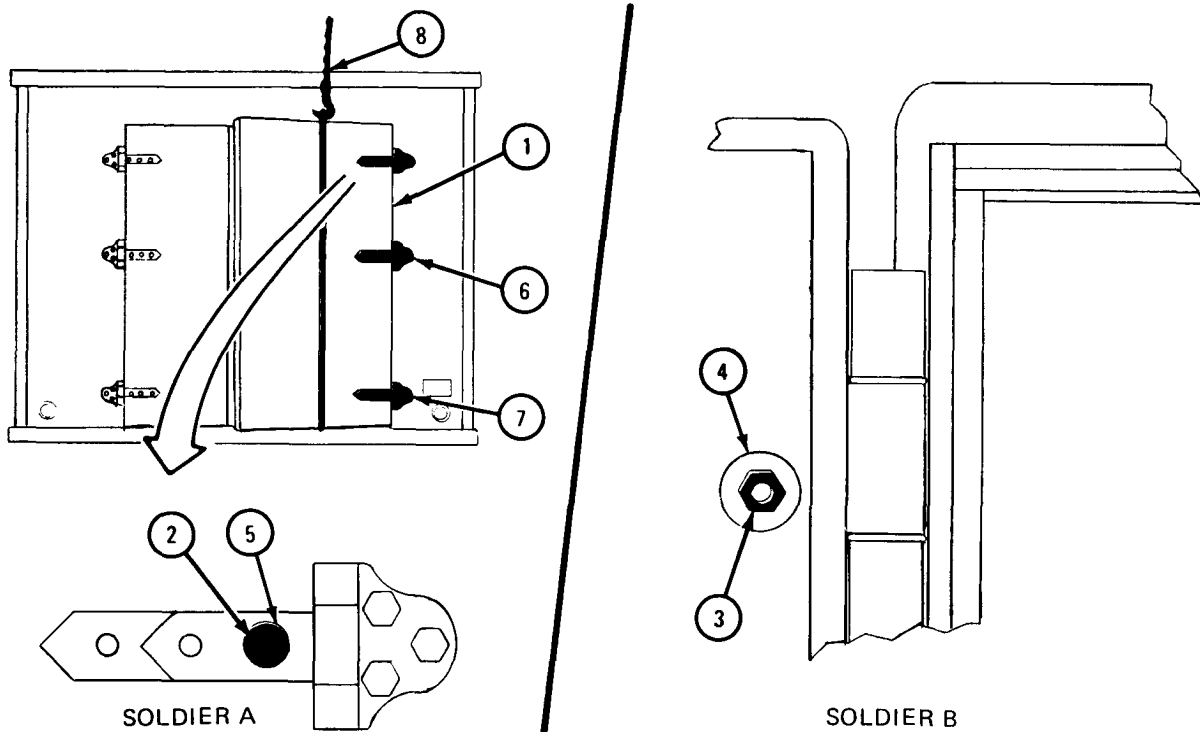

TA 047534

c. Replacement.

FRAME 1

- Soldier A 1. Guide door (1) as it is lifted into place.
- Soldier B 2. Using hoist sling (2), lift door (1) into place, partway open.
- Soldier A 3. Working on outside of door (1), aline screw holes in door and hinge (3). Put in cap screw (4) with washer (5). Using 1/2-inch wrench, hold cap screw and tell soldier B when ready.
- Soldier B 4. Working on inside of door (1), using 1/2-inch socket wrench, screw on and tighten locknut (6) through access hole (7).
- Soldiers A and B 5. Do steps 2 and 3 again for hinges (8 and 9) on center and bottom of door (1).
- GO TO FRAME 2

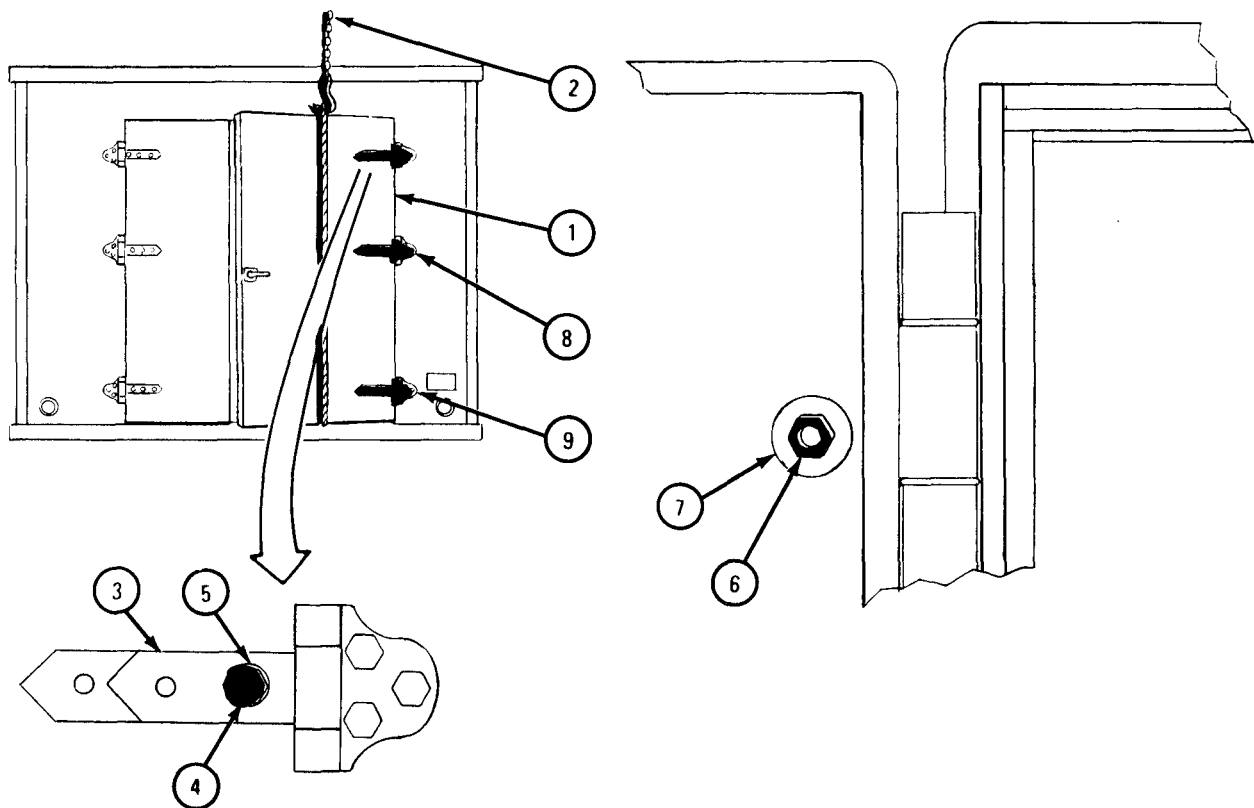

TA 047535



**FRAME 2**

1. Working on outside of door (1), using 1/2-inch socket wrench, screw in and tighten two capscrews (2) and lockwashers (3) in top door hinges (4 and 5). Using 1/2-inch socket wrench, screw in and tighten cap screw (6) and lockwasher (7) in center door hinge (8).
2. Take off hoist sling (9) and hoist equipment (10).

GO TO FRAME 3

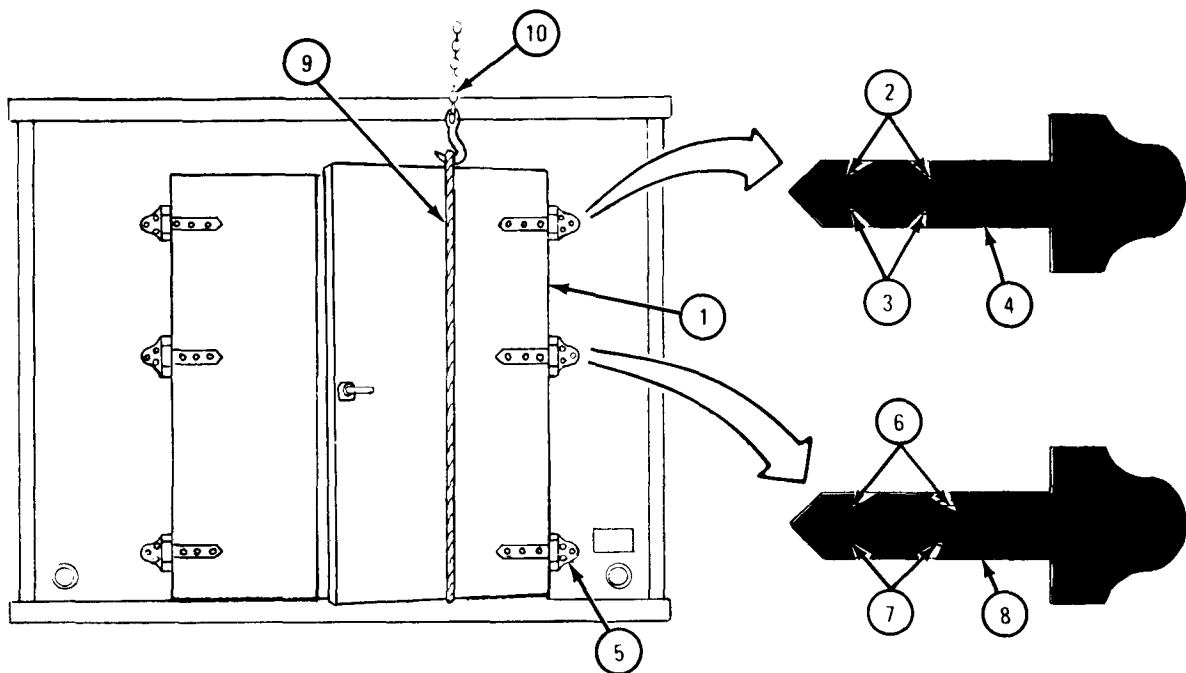

TA 047536

FRAME 3

1. Working inside truck, close door (1) and align screw holes in door check (2) and door.
2. Using screwdriver, screw in and tighten two screws (3).

NOTE

Follow-on Maintenance Action Required:

If left rear door was worked on, replace ladder. Refer to TM 9-2320-209-10.

END OF TASK

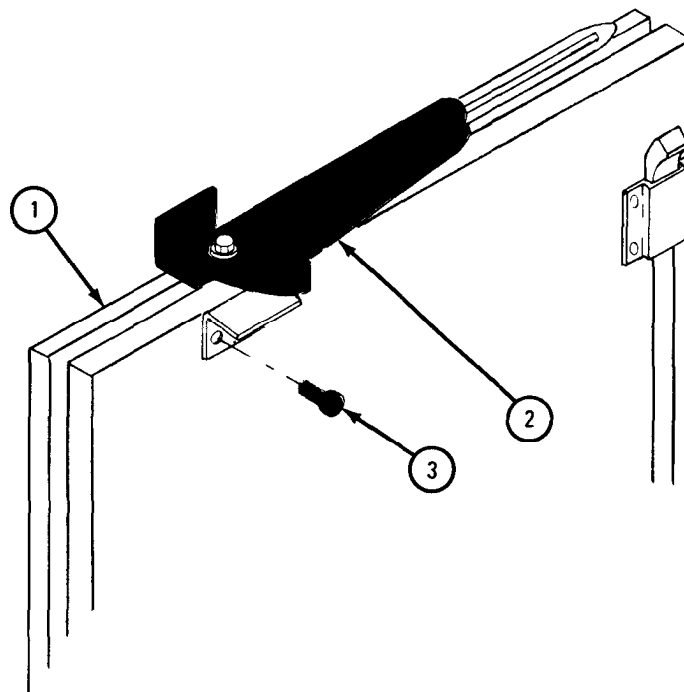

TA 047537

18-76. DOOR SEALS REMOVAL AND REPLACEMENT (TRUCKS M109A2, M109A3, M185A2 AND M185A3).

TOOLS: Wire brush  
Flat-tip screwdriver

SUPPLIES: Adhesive, Fed. Spec MMM-A-139  
Denatured alcohol, MIL-STD-1201  
Stepladder, 10-foot

PERSONNEL: One

EQUIPMENT CONDITION: Truck parked, engine off, handbrake set.

a. Removal.

FRAME 1

1. Open doors (1) and hook in fully open position.
2. Using screwdriver, pry out corner of seal (2) from channel (3) on door opening (4).
3. Pull out seal (2) around door openings (4) by hand.

GO TO FRAME 2

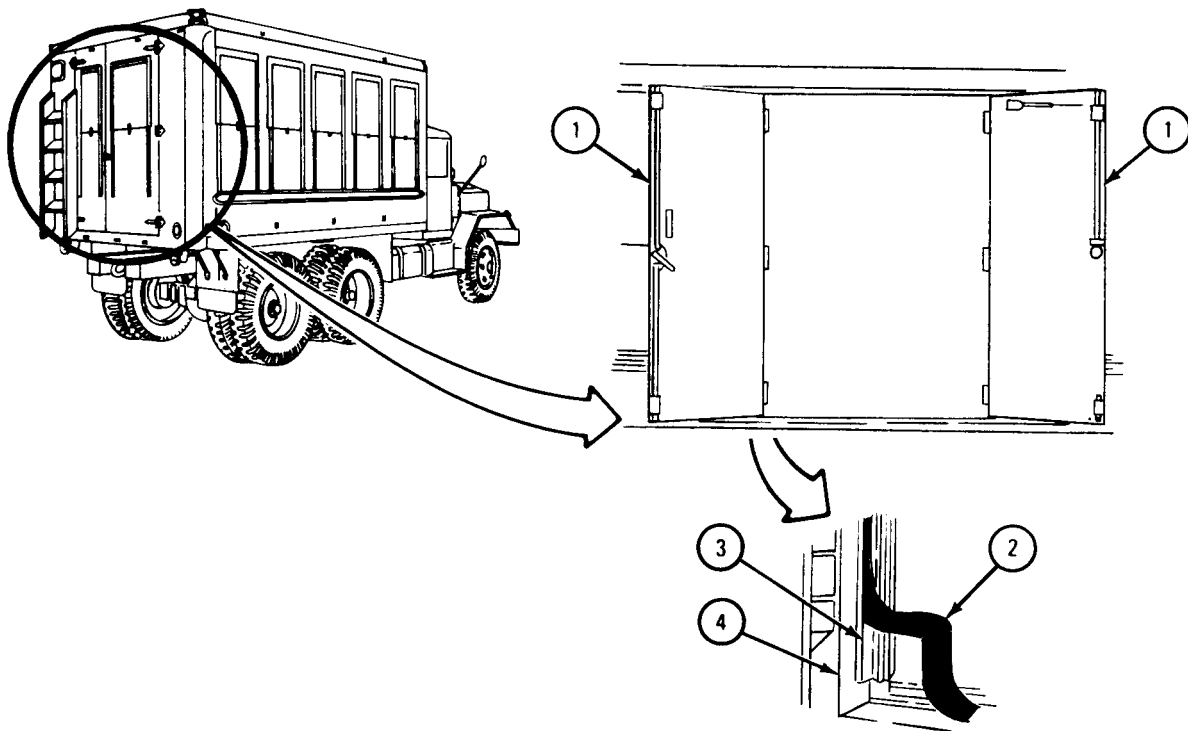

TA 085575

FRAME 2

1. Working at left door (1), using screwdriver, pry out corner of seal (2) from channel (3) on door end (4). Pull out seal (2) by hand.

END OF TASK

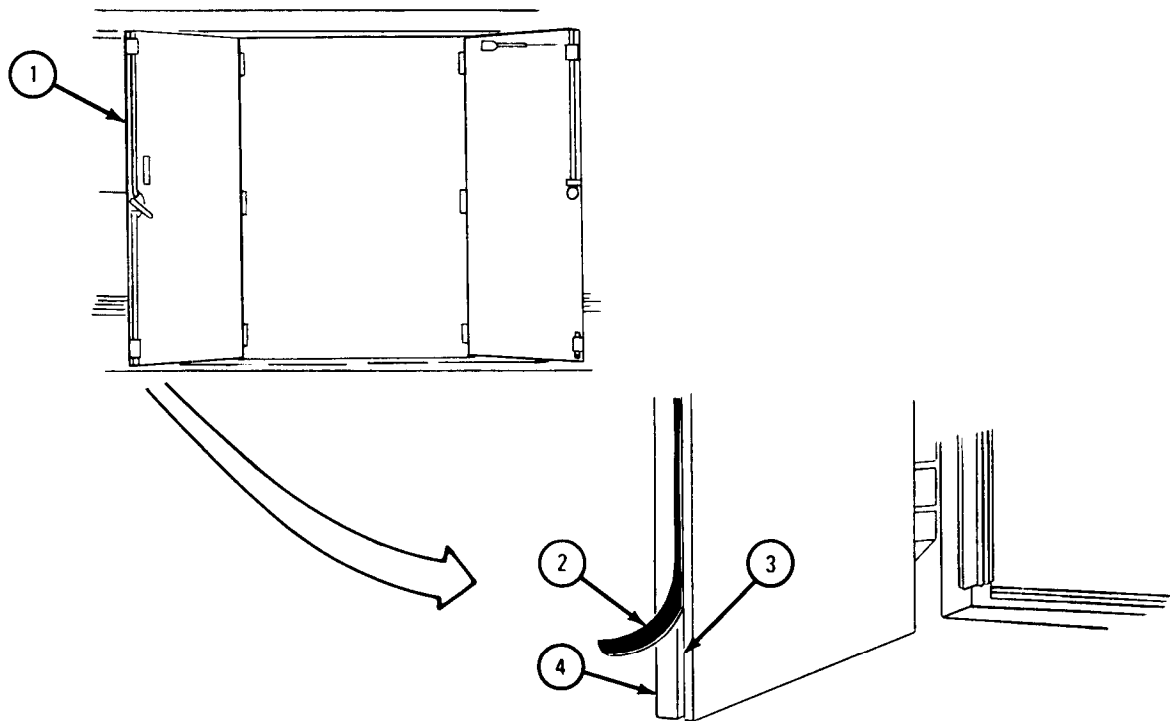

TA 085576

b. Replacement.

## FRAME 1

WARNING

Denatured alcohol and adhesive are flammable. Do not use near an open flame. Keep a fire extinguisher nearby when solvent is used. Use only in well-ventilated places. Failure to do this may result in injury to personnel and damage to equipment.

1. Using denatured alcohol and wire brush, clean channels (1 and 2) free of dirt and dried adhesive.
2. Coat channels (1 and 2) with adhesive.
3. Using screwdriver, put one corner of seal (3) in channel (1) in bottom left-hand corner (5) first.
4. Using screwdriver, push seal (3) into channel (1) all around opening. Push seal by hand to be sure it fits tightly in channel.
5. Using screwdriver, push one end of seal (4) in one end of channel (2) and run hand behind screwdriver so seal fits tightly in channel.
6. Unhook and close doors.

END OF TASK

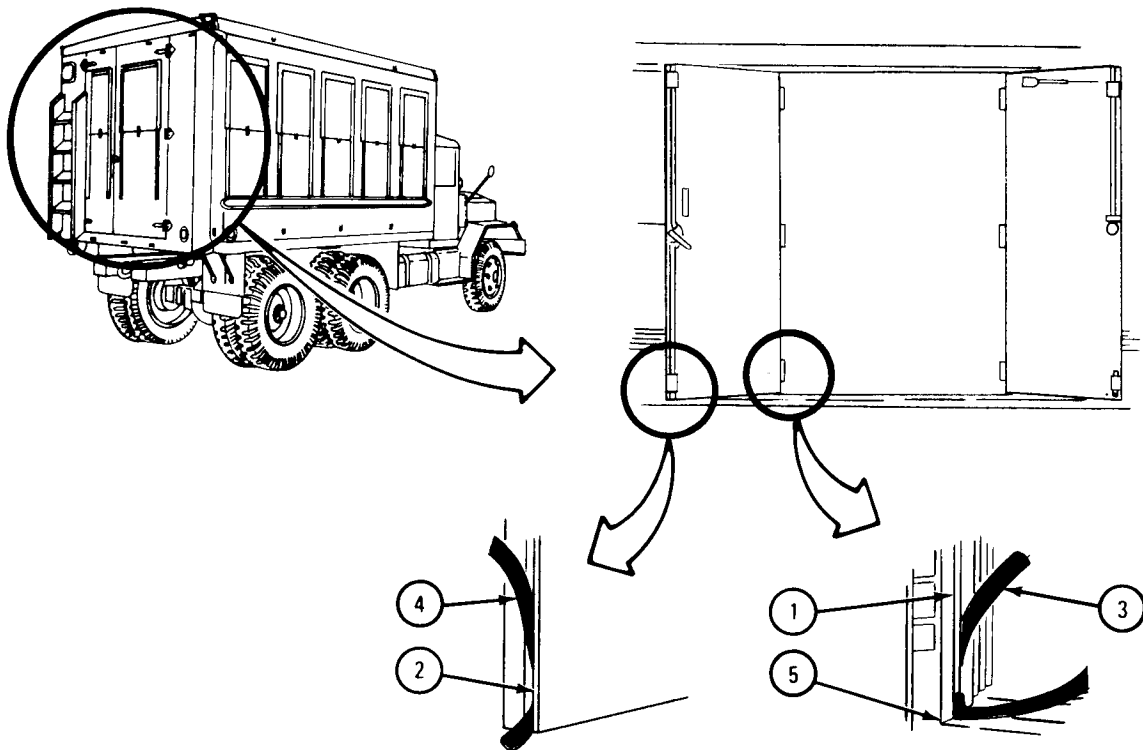

TA 101597

18-77. VAN DOOR REPAIR (TRUCKS M109A2, M109A3, M185A2, AND M185A3).

TOOLS:     Pliers  
          7/16-inch wrench  
          9/16-inch wrench  
          Cross-tip screwdriver (Phillips type )

SUPPLIES:   Solvent, dry cleaning, type II (SD-2), Fed. Spec P-D-680  
          Clean rags

PERSONNEL:   One

EQUIPMENT CONDITION: Truck parked, engine off, handbrake set.

a.   Preliminary Procedure. Remove van doors. Refer to para 18-75.

b. Disassembly.

(1) Left van door.

**FRAME 1**

1. Working on front of door, using screwdriver, unscrew and take out two screws (1) and take off clip (2).
2. Using screwdriver, unscrew and take out four screws (3) and washers (4).
3. Take off plate (5).
4. Working on back of door, using screwdriver, unscrew and take out four screws (6) and washers (7).
5. Take off latch (8).

GO TO FRAME 2

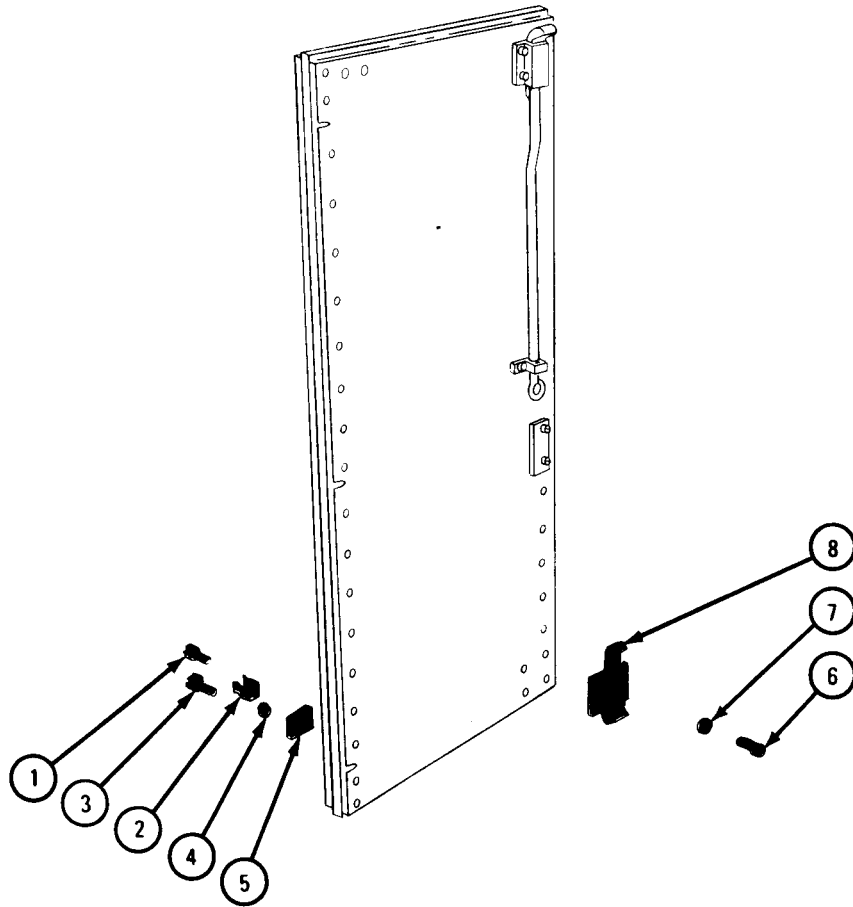

TA 088380

**FRAME 2**

1. Using 7/16-inch wrench, unscrew and take out two capscrews (1) and take off plate (2).
2. Using screwdriver, unscrew and take out two screws (3) and take off guide (4).
3. Using screwdriver, unscrew and take out four screws (5) and washers (6).
4. Take off latch (7) with rod (8).
5. Take off rubber seal (9).

END OF TASK

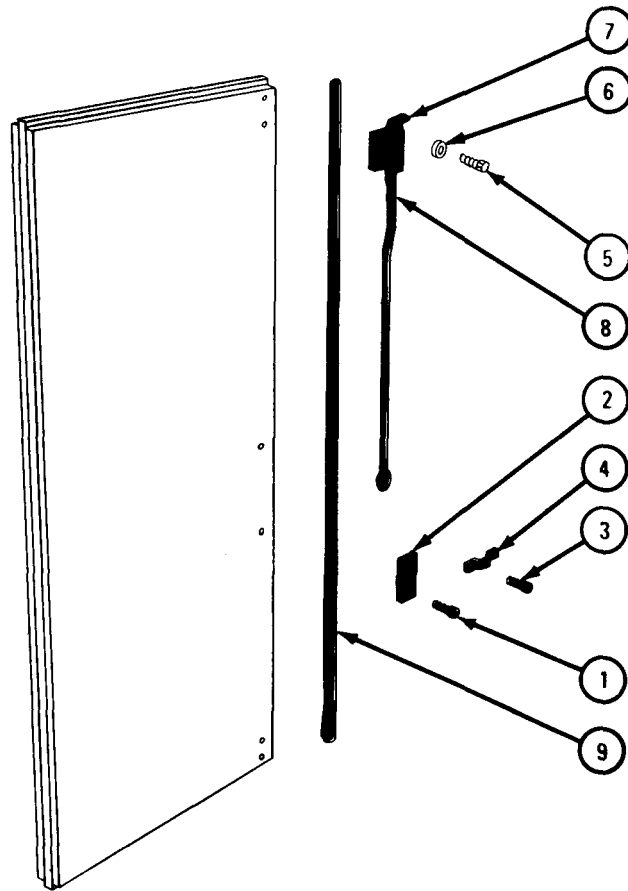

TA 088381



(2) Right van door.

FRAME 1

1. Using screwdriver, unscrew and take out two screws (1) and take off holder (2).
2. Using screwdriver, unscrew and take out four screws (3).
3. Take off guide (4) and two spacers (5).
4. Do steps 3 and 4 again on bottom of door (6).

GO TO FRAME 2

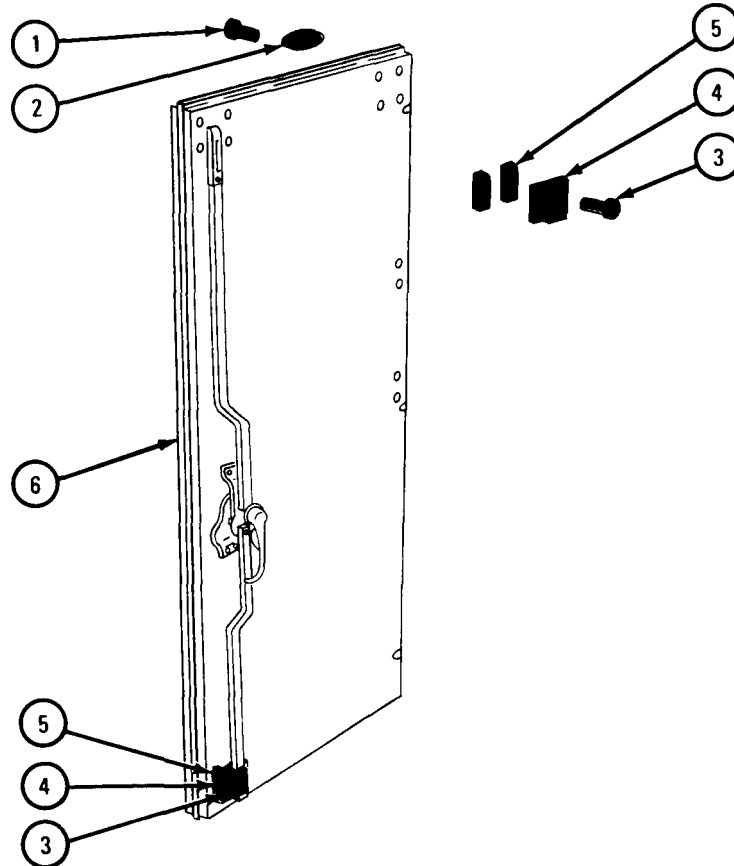

TA 088383

**FRAME 2**

1. Using 9/16-inch wrench, unscrew and take out capscrew (1) and take off slide (2) .
  2. Do step 1 on bottom of door (3) .
  3. Take out pin (4) and take off handle (5) .
  4. Using pliers, take out and throw away two cotter pins (6) .
  5. Take off upper rod (7) and lower rod (8) .
- GO TO FRAME 3

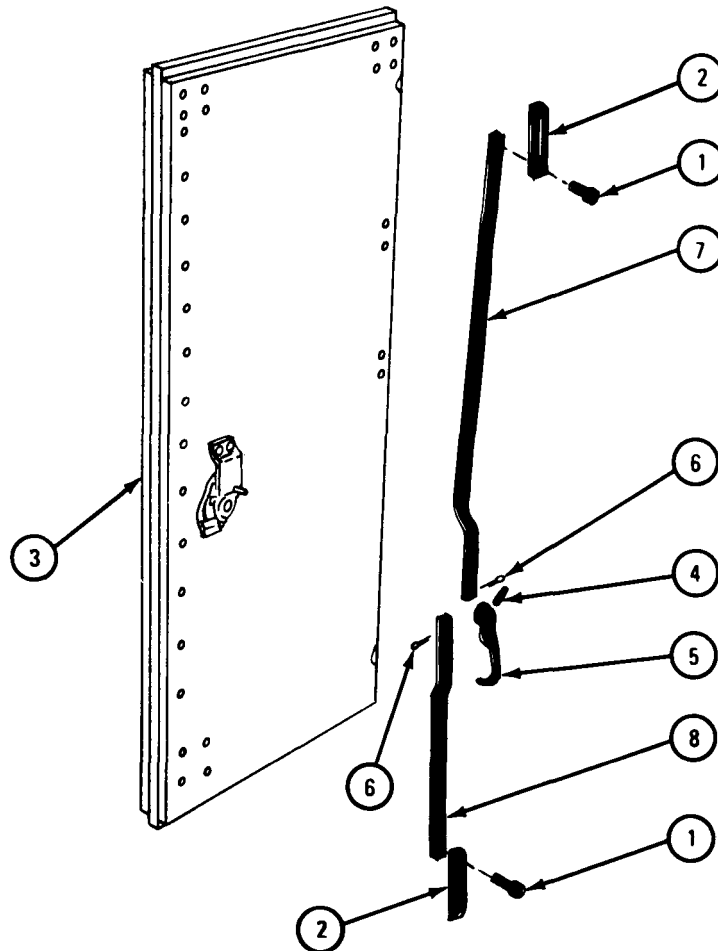

TA 088384

## FRAME 3

1. Using 7/16-inch wrench, unscrew and take out three cap screws and washers (1).
  2. Take off handle (2) .
  3. Using screwdriver, unscrew and take out screw (3) and take off lock (4) .
- GO TO FRAME 4

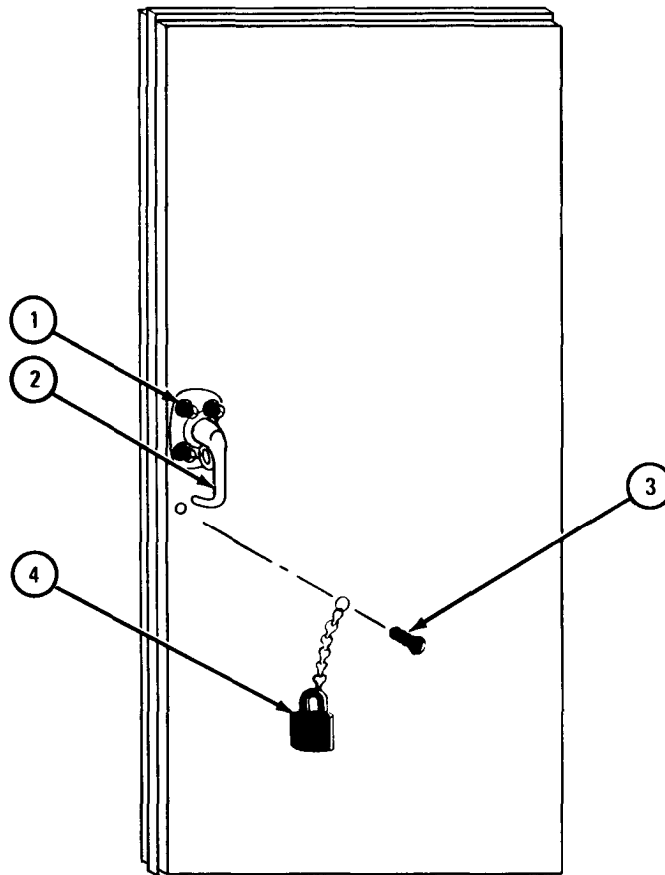

TA 088382

FRAME 4

1. Using 7/16-inch wrench, unscrew and take out four capscrews (1) and washers (2).
2. Take lock assembly (3) off door (4).

END OF TASK

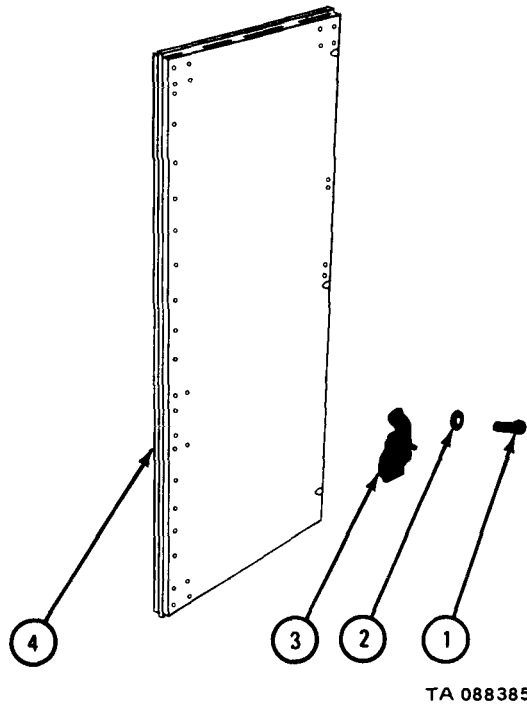

c. Cleaning.

WARNING

Dry cleaning solvent is flammable. Do not use near an open flame. Keep a fire extinguisher nearby when solvent is used. Use only in well-ventilated places. Failure to do this may result in injury to personnel and damage to equipment.

- (1) Clean parts using solvent.
- (2) Dry parts with clean rags.

d. Inspection and Repair.

FRAME 1

1. Check that rubber seal (1) is not torn or damaged. If seal is damaged, get a new one.
2. Check that door (2) is not bent, cracked or damaged. Straighten or weld damaged door. Refer to TM 9-237. If more repair is needed, get a new door.
3. Check that latch (3), lock (4), and guide (5) are not bent, cracked or damaged. Straighten or weld damaged parts. Refer to TM 9-237. If more repair is needed, get new parts.
4. Check that two plates (6), latch (7), two holders (8), and clip (9) are not bent, cracked or damaged. Straighten or weld damaged parts. Refer to TM 9-237. If more repair is needed, get new parts.

GO TO FRAME 2

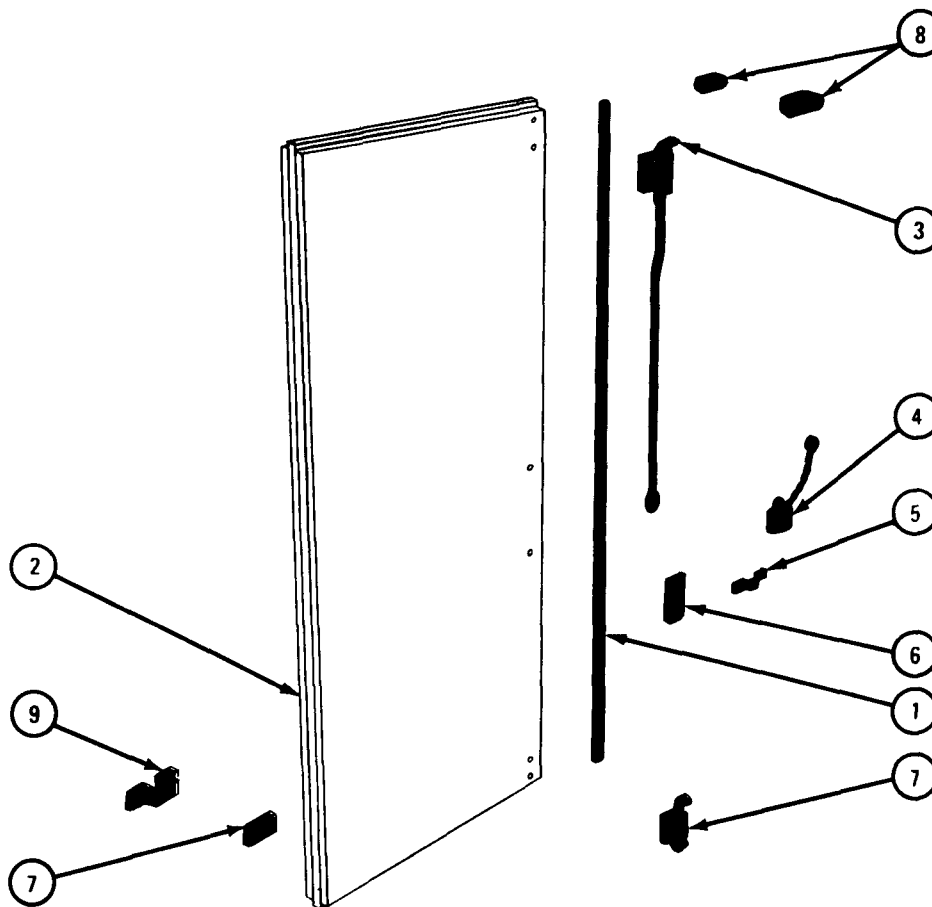

TA 088386

**FRAME 2**

1. Check that four spacers (1), two guides (2), door (3), and two slides (4) are not bent, cracked or damaged. Straighten or weld damaged parts. Refer to TM 9-237. If more repair is needed, get new parts.
2. Check that upper rod (5), lower rod (6), lock assembly (7), and handle (8) are not bent, cracked or damaged. Straighten or weld damaged parts. Refer to TM 9-237. If more repair is needed, get new parts.

END OF TASK

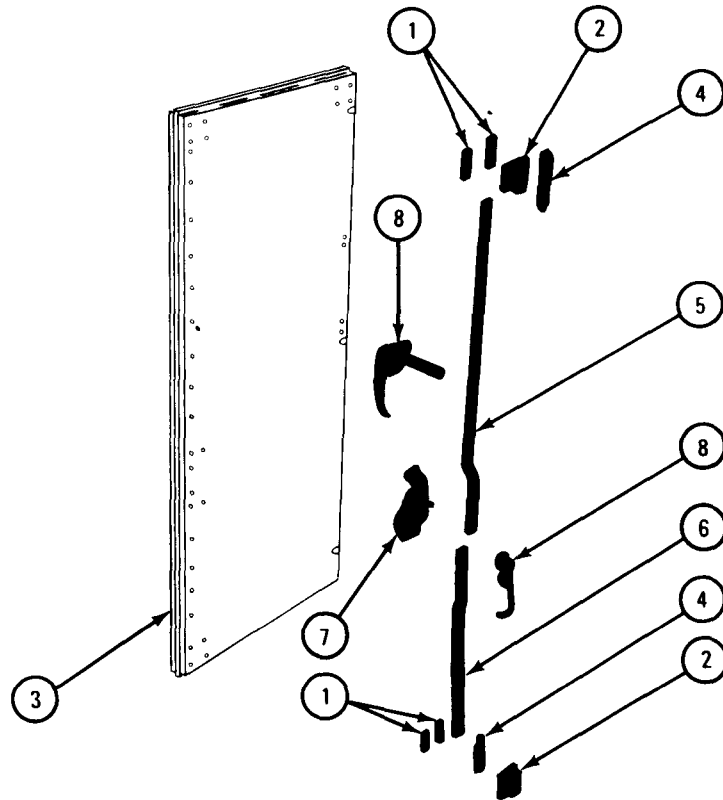

TA 088387

e. Assembly.

(1) Right van door.

**FRAME 1**

1. Put lock assembly (1) in place on door (2).
2. Using 7/16-inch wrench, screw in and tighten four washers (3) and capscrews (4).

GO TO FRAME 2

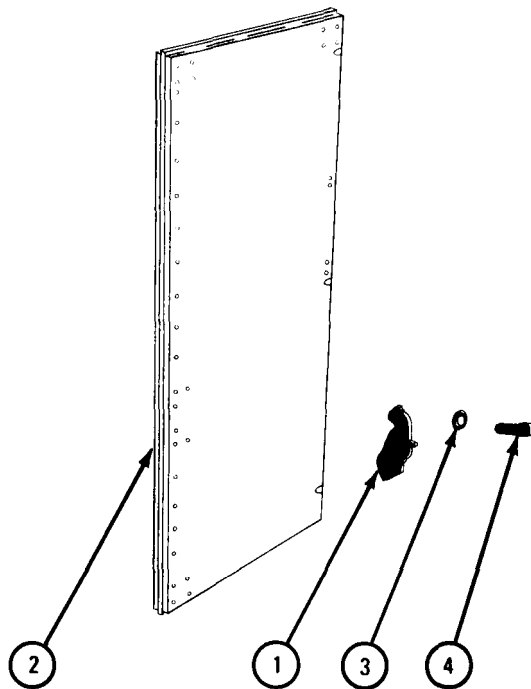

TA 088388



## FRAME 2

1. Put lock (1) in place and using 7/16-inch wrench, screw in and tighten capscrew (2).
  2. Put handle (3) in place.
  3. Using screwdriver, screw in and tighten three screws and washers (4) .
- GO TO FRAME 3

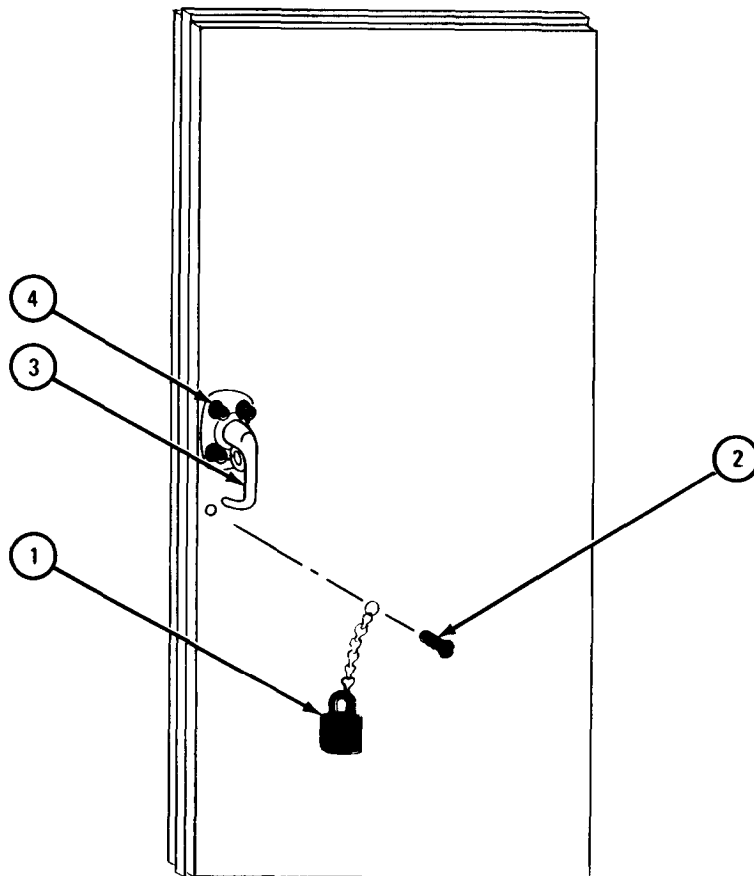

TA 088391

FRAME 3

1. Put upper rod (1) and lower rod (2) in place.
2. Put in two cotter pins (3). Using pliers, bend open ends of cotter pins.
3. Put handle (4) in place and put in pin (5) .
4. Put slide (6) in place and using 9/16-inch wrench, screw in and tighten two cap screws (7) .
5. Do step 4 again on bottom of door ( 8).

GO TO FRAME 4

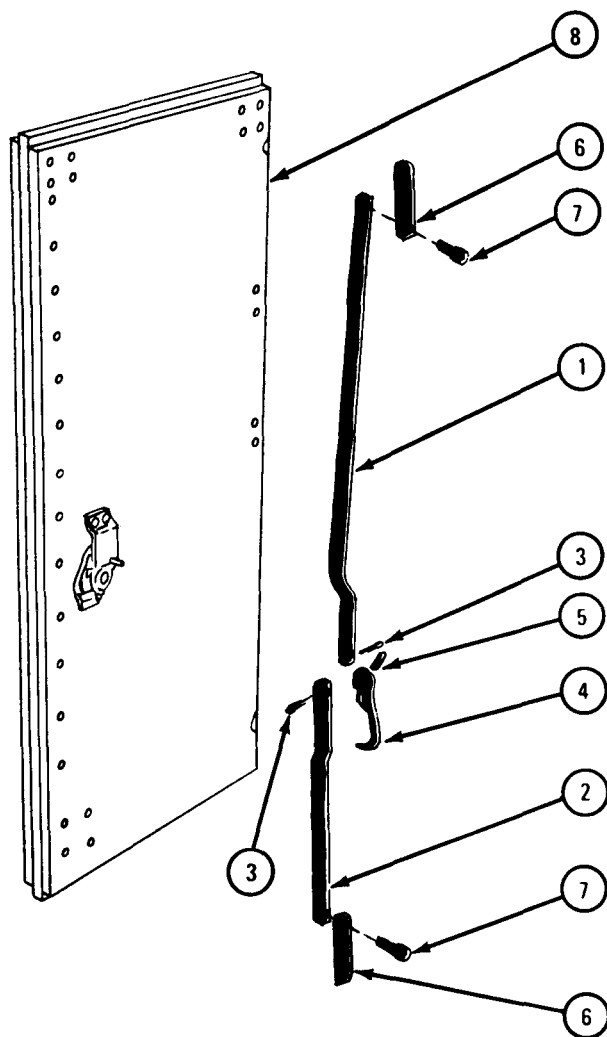

TA 088389

**FRAME 4**

1. Put two spacers (1) and guide (2) in place.
2. Using screwdriver, screw in and tighten four screws (3).
3. Do steps 1 and 2 again on bottom of door (4).
4. Put holder (5) in place and using screwdriver, screw in and tighten two screws (6).
5. Do step 4 again on other side of door (4).

END OF TASK

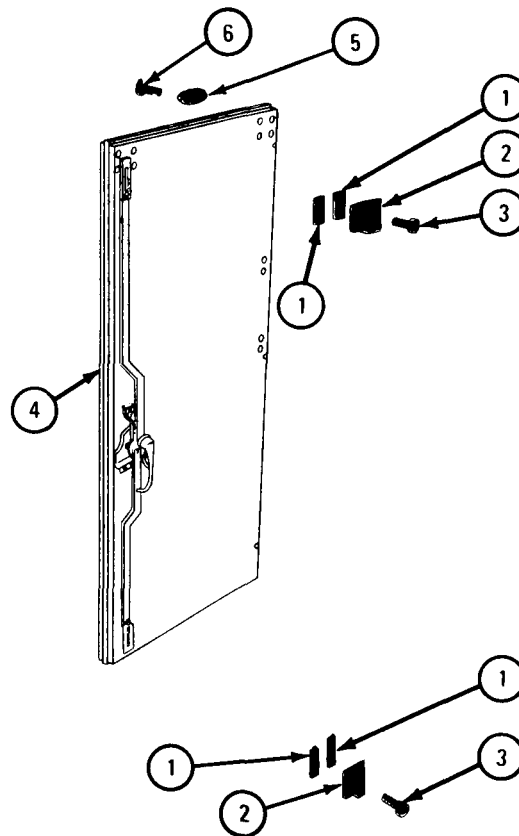

TA C88390

(2) Left van door.

FRAME 1

1. Put rubber seal (1) in place.
2. Put latch (2) in place.
3. Using screwdriver, screw in and tighten four washers (3) and cap screws (4).
4. Put guide (5) in place and using screwdriver, screw in and tighten two screws (6).
5. Put plate (7) in place and using screwdriver, screw in and tighten two screws (8).

GO TO FRAME 2

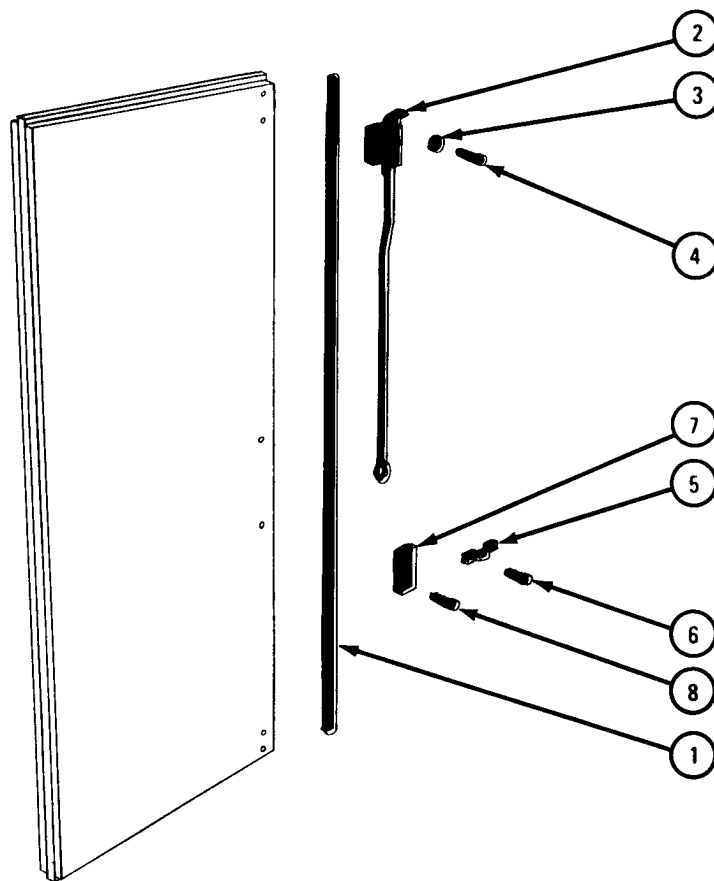

TA 088392

**FRAME 3**

1. Put latch (1) in place.
2. Using screwdriver, screw in and tighten four washers (2) and screws (3) .
3. Put plate (4) in place.
4. Using screwdriver, screw in and tighten four washers (5) and screws (6) .
5. Put clip (7) in place and using screwdriver, screw in and tighten two screws (8).

**NOTE**

Follow-on Maintenance Action Required:

Replace van doors on truck. Refer to para 18-75.

END OF TASK

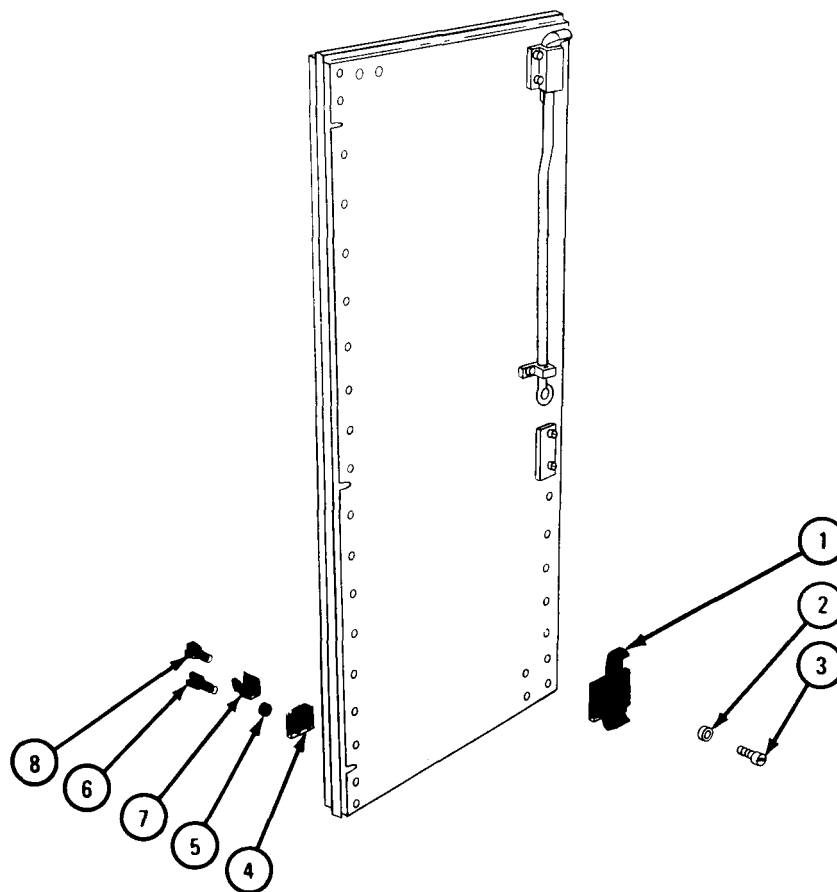

TA 088393

18-78. HORIZONTAL LEVELING WORM DRIVE CHAIN REMOVAL AND REPLACEMENT  
(TRUCK M764).

NOTE

This task is the same for the first and second reduction chains. This task is shown for the second reduction chain.

TOOLS: Adjustable wrench  
15/16-inch wrench  
Flat-tip screwdriver  
Pliers  
2-inch open end wrench  
1 1/8-inch open end wrench  
5/32-inch sockethead screw key  
(Allen wrench or equivalent)  
3/4-inch wrench (2)  
7/16-inch wrench

SUPPLIES: None

PERSONNEL: One

EQUIPMENT CONDITION: Truck parked, engine off, handbrake set.

a. Removal.

FRAME 1

1. Using screwdriver, take off safety wire (1). Using allen wrench, loosen setscrew (2). Take off cover retaining collar (3).
2. Using 7/16-inch wrenches, unscrew and take off capscrew (4), lockwasher (5), and nut (6).
3. Using 15/16-inch wrench, unscrew and take off capscrew with lockwasher (7), flat washer (8), and bushing (9). Take off cover (10).

GO TO FRAME 2

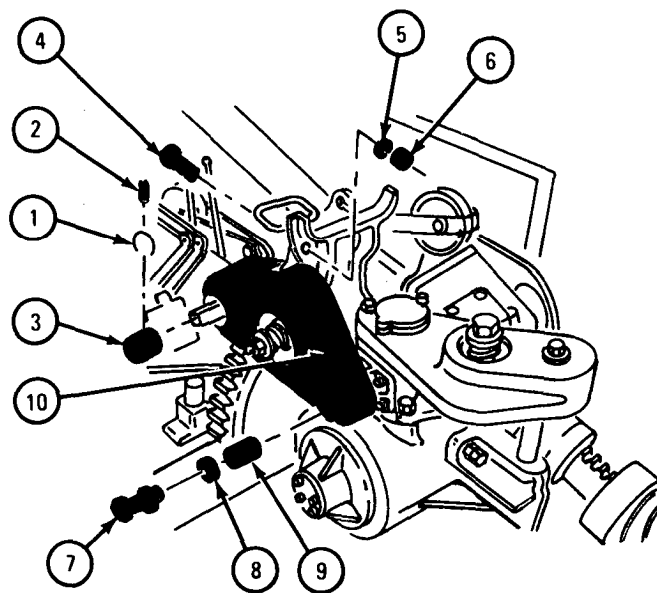
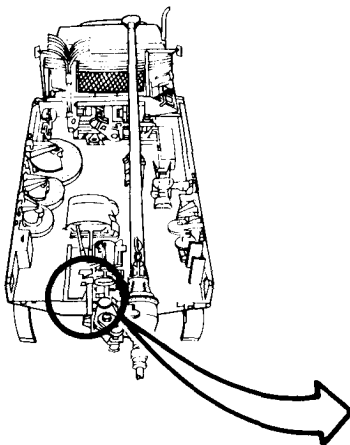

TA 047474

## FRAME 2

1. Using 3/4-inch wrench, hold capscrew (1). Using 3/4-inch wrench, loosen nut (2).
2. Using 1 1/8-inch open end wrench and 2-inch open end wrench, hold chain tightening shaft (3) and turn eccentric bushing (4) until first reduction drive chain (5) and second reduction driven chain (6) are loose.

GO TO FRAME 3

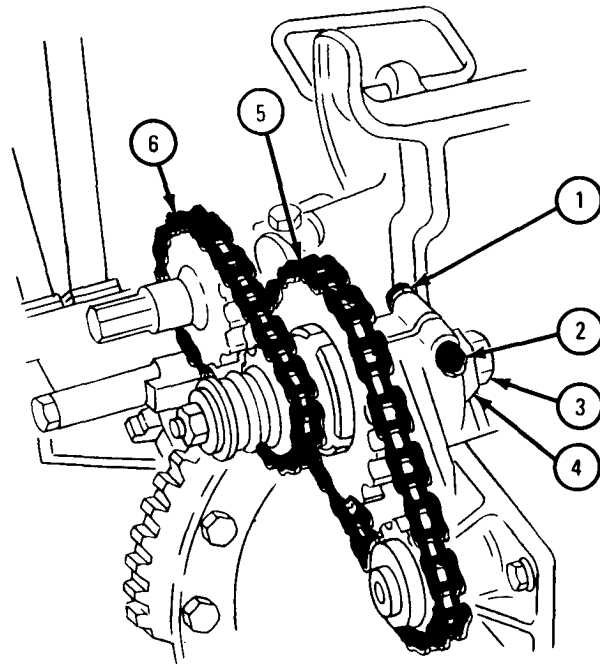

TA 047475

**FRAME 3**

1. Find removable connecting link (1) on chain (2).
2. Using pliers, take off two cotter pins (3) from connecting link pins (4) and take off link plate (5).
3. Take out connecting link (1) from chain (2) and take off chain from sprockets (6).

END OF TASK

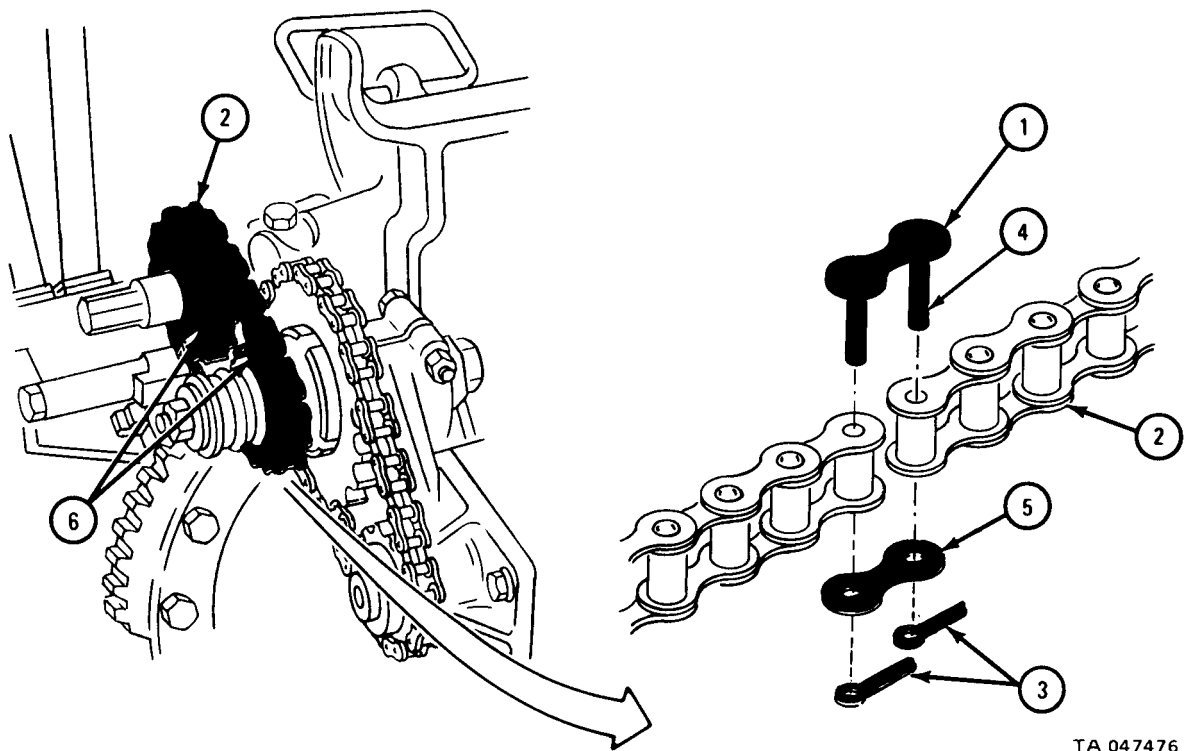

TA 047476



b. Replacement.

**FRAME 1**

1. Put chain (1) on sprockets (2).

GO TO FRAME 2

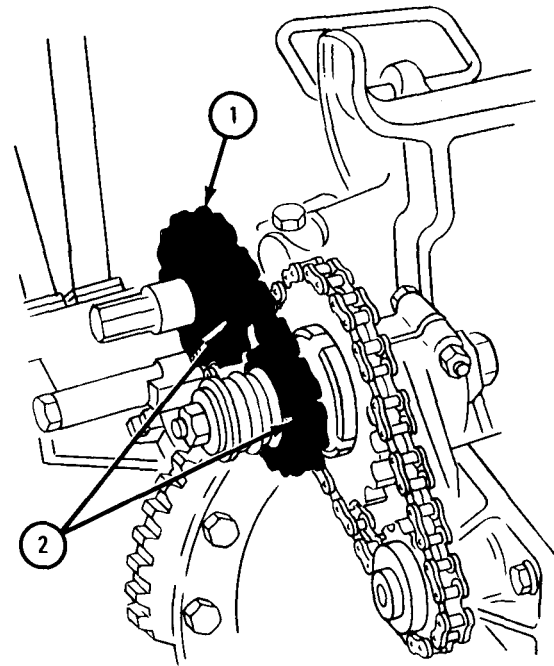
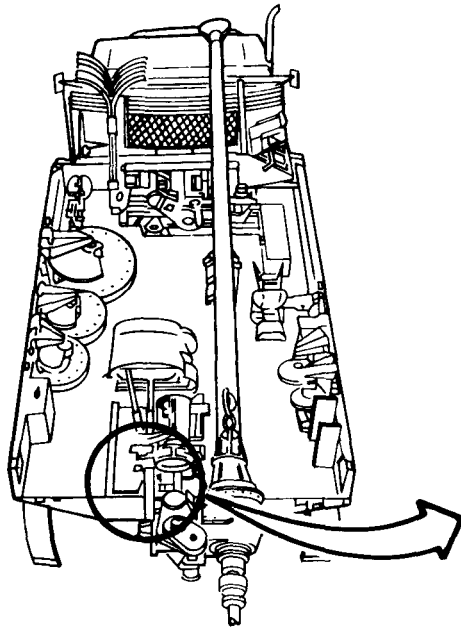

TA 047477

FRAME 2

1. Put connecting link pins (1) in two ends of chain (2). Put link plate (3) on connecting link pins.
2. Using pliers, put in and bend open ends of two cotter pins (4).
3. Adjust chains. Refer to para 18-80.

GO TO FRAME 3

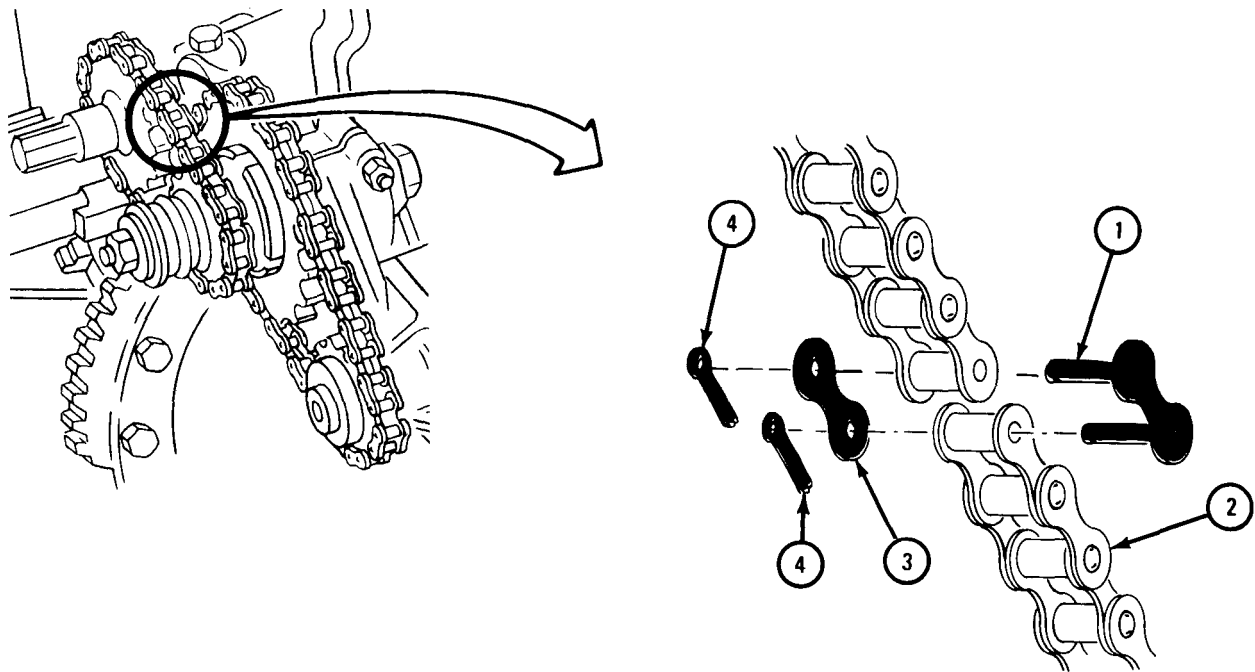

TA 047478

## FRAME 3

1. Put cover (1) in place as shown.
2. Using 15/16-inch wrench, screw in and tighten capscrew (2), flat washer (3), lockwasher (4), and bushing (5).
3. Using 7/16-inch wrenches, screw in and tighten capscrew (6), lockwasher (7), and nut (8) .
4. Put on cover retaining collar (9), alining setscrew hole in collar with slot.
5. Using allen wrench, screw in and tighten setscrew (10). Put safety wire over setscrew and on collar (9).

END OF TASK

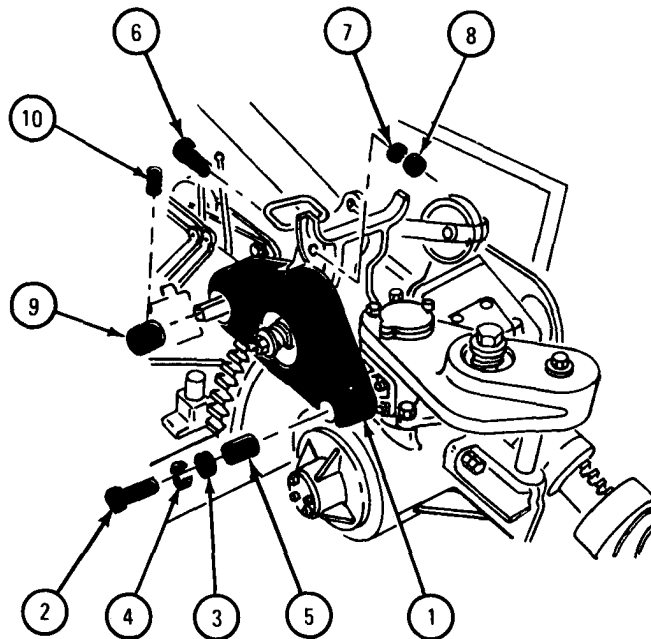

TA 047479

18-79. VERTICAL LEVELING WORM DRIVE CHAIN REMOVAL AND REPLACEMENT  
(TRUCK M764).

NOTE

This task is the same for the first and second reduction chains. This task is shown for the second reduction chain.

TOOLS :   Adjustable wrench                               Pliers  
          15/16-inch open end wrench               3/4-inch wrench (2)  
          Flat-tip screwdriver                       1 1/8-inch wrench

SUPPLIES :   Removable connecting link

PERSONNEL:   One

EQUIPMENT CONDITION :   Truck parked, engine off, handbrake set.

a. Removal.

**FRAME 1**

1. Using 15/16-inch wrench, unscrew and take off nut (1) and lockwasher (2).
2. Using 15/16-inch wrench, unscrew and take off capscrew (3), lockwasher (4), flat washer (5), and bushing (6) . Take off cover (7).

GO TO FRAME 2

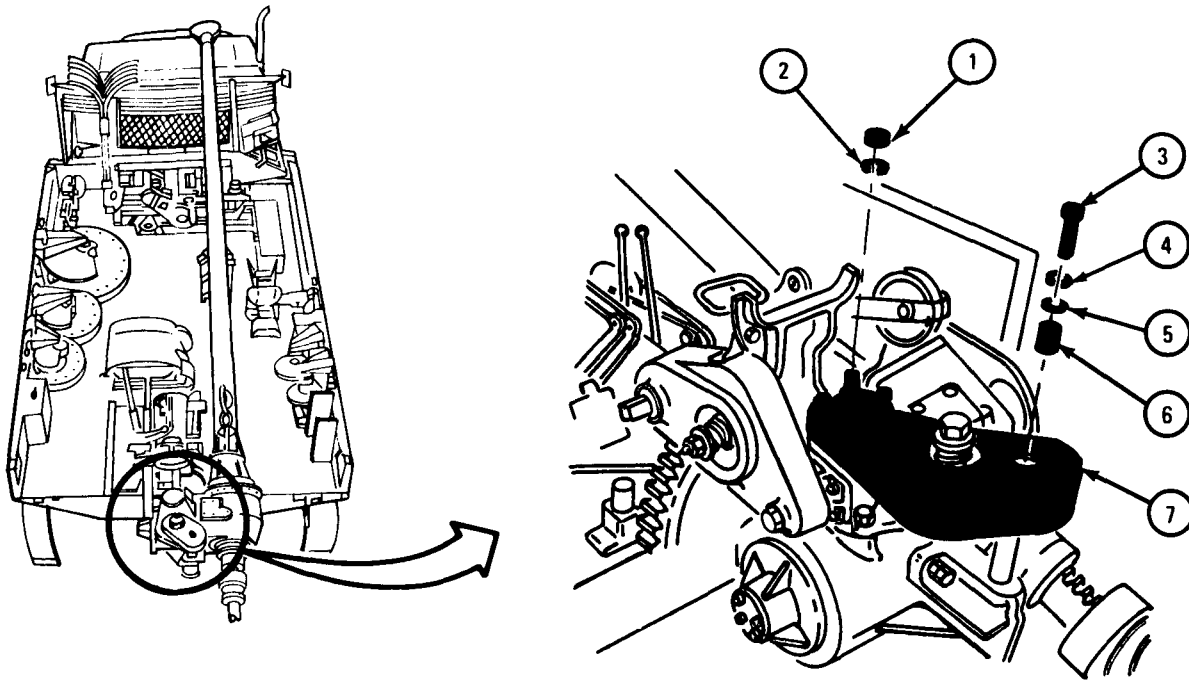

TA 047462

## FRAME 2

1. Using 3/4-inch wrenches, unscrew and loosen capscrew (1) and nut (2).
2. Using 1 1/8-inch and adjustable wrench hold chain tightening shaft (3) and turn eccentric bushing (4) until first reduction drive chain (5) and second reduction driven chain (6) are loose.

GO TO FRAME 3

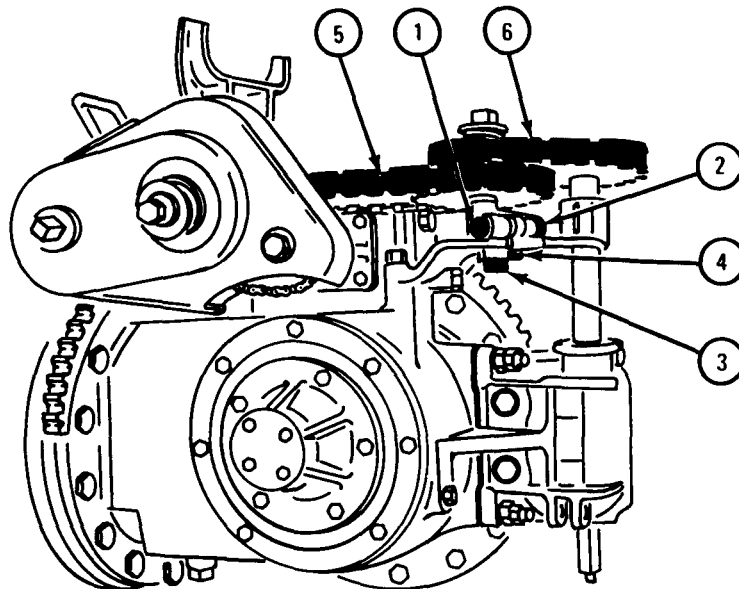

TA 047463

FRAME 3

1. Find removable connecting link (1) on chain (2).

NOTE

Connecting link pins (3) may have connector plate (4) or two cotter pins (5).

2. If connecting link pins (3) have connector plate (4) , using screwdriver, take off connector plate from connecting link pins and take off link plate (6).
3. If connecting link pins (3) have two cotter pins (5), using pliers, take out two cotter pins from connecting link pins. Take off link plate (6).
4. Take connecting link (1) from end of chain (2) and take off chain from sprockets (7).

END OF TASK

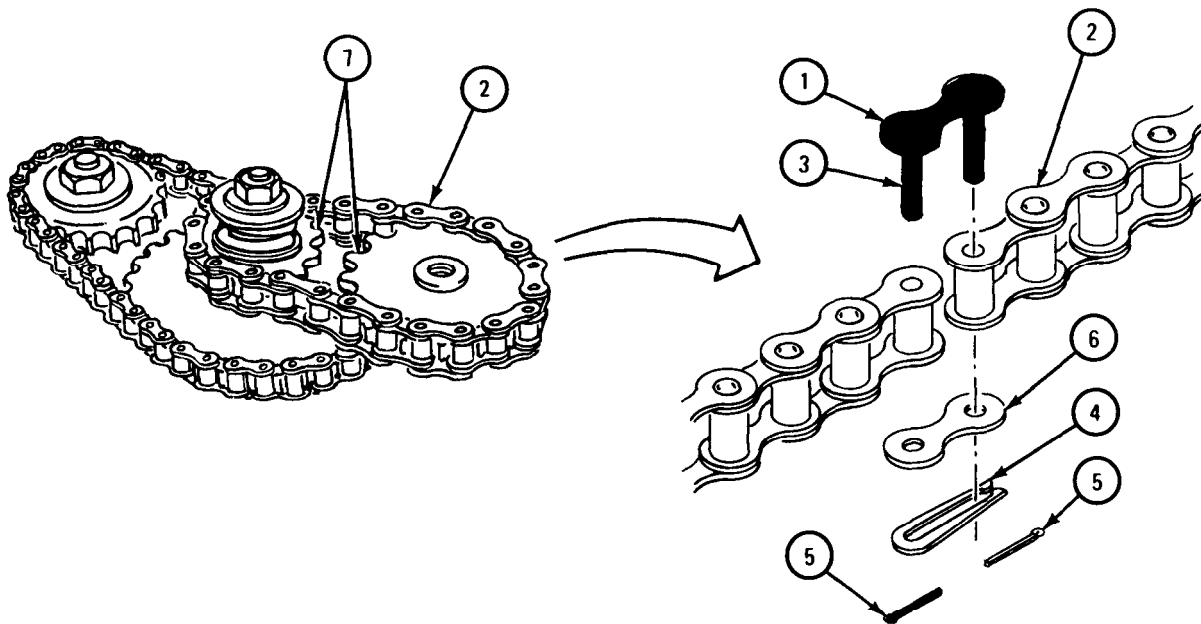

TA 047464

b. Replacement.

FRAME 1

1. Put chain (1) on sprockets (2).

GO TO FRAME 2

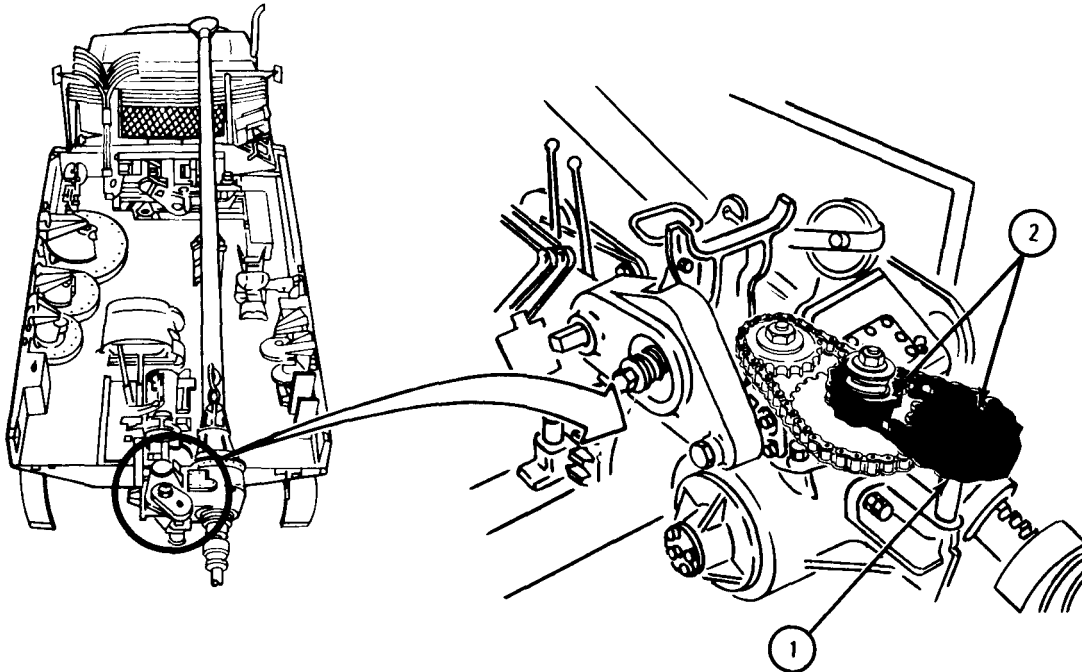

TA 047465

FRAME 2

1. Put connecting link pins (1) into two ends of chain (2). Put link plate (3) on connecting link pins.

NOTE

Connecting link pins (1) may have connector plate (4) or two cotter pins (5) .

2. If connecting link pins (1) have a connector plate (4), clip connector plate over link plate (3) and on connecting link pins.
3. If connecting link pins (1) have two cotter pins (5) , using pliers, put in and spread open two cotter pins.
4. Adjust chains. Refer to para 18-80.

GO TO FRAME 3

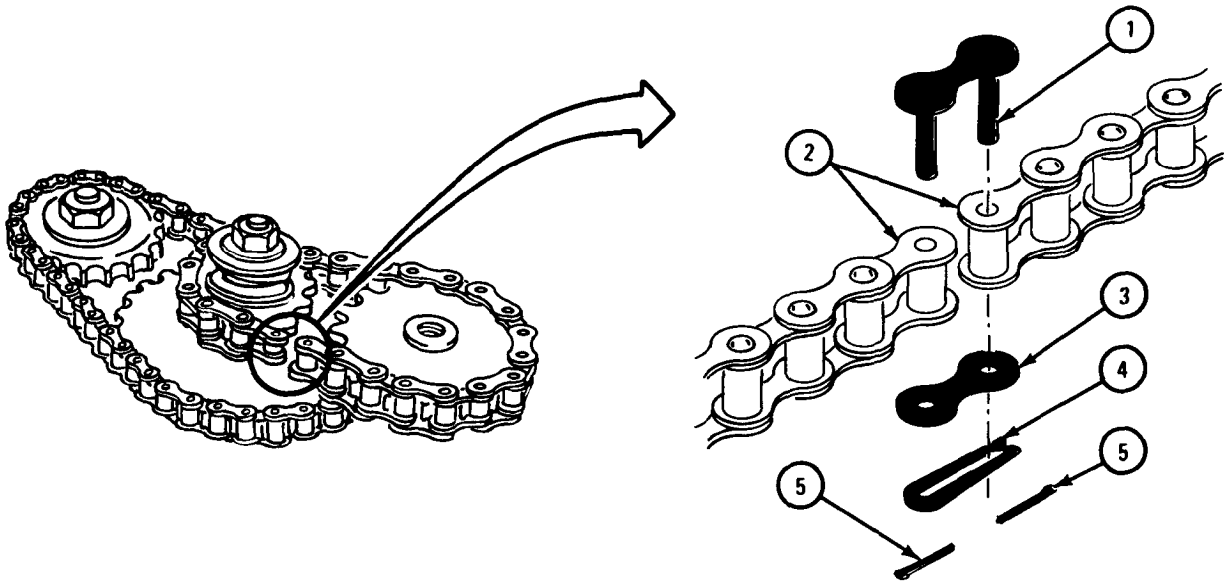

TA 047466



## FRAME 3

1. Put cover (1) in place as shown.
  2. Using 15/16-inch wrench, screw on and tighten capscrew (2), flat washer (3), lockwasher (4), and bushing (5).
  3. Using 15/16-inch wrench, screw on and tighten lockwasher (6) and nut (7).
- END OF TASK

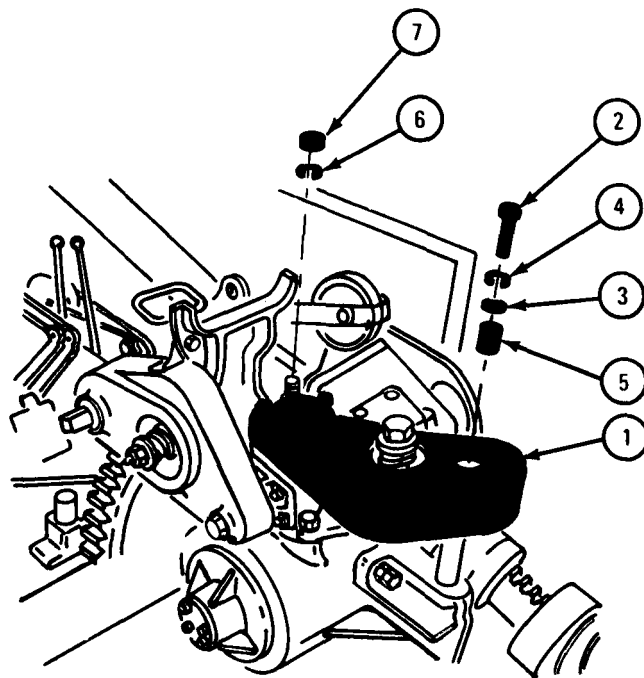

TA 047467

18-80. LEVELING WORM DRIVE CHAIN ADJUSTMENT (TRUCK M764).

TOOLS :     2-inch wrench                     6-inch ruler  
          3/4-inch wrench                 1 1/8-inch wrench  
          12-inch ruler

SUPPLIES :   None

PERSONNEL:   One

EQUIPMENT CONDITION : Truck parked, engine off, handbrake set.

a. Preliminary Procedure. Take off leveling worm drive chain cover. Refer to para 18-78 for horizontal leveling worm drive chain cover removal. Refer to para 18-79 for vertical leveling worm drive chain cover removal.

b. Adjustment.

## NOTE

This task is the same for the horizontal and vertical leveling worm drive chains. This task is shown for the horizontal leveling worm drive chain.

## FRAME 1

1. Check free play by putting 12-inch ruler on chain (1) as shown. Firmly push down on chain with zero end of 6-inch ruler halfway between sprockets (2). Read free play on 6-inch ruler at bottom edge of 12-inch ruler.
2. Using 3/4-inch wrenches, loosen capscrew (3) and nut (4).
3. Using 1 1/8-inch wrench and 2-inch wrench, hold chain tightening shaft (5) and turn eccentric bushing (6) until free play is 1/2 inch on chains (1 and 7).
4. Using 3/4-inch wrenches, tighten capscrew (3) and nut (4).

## NOTE

## Follow-on Maintenance Action Required:

Put on leveling worm drive chain cover. Refer to para 18-78 for horizontal leveling worm drive chain cover replacement. Refer to para 18-79 for vertical leveling worm drive chain cover replacement.

END OF TASK

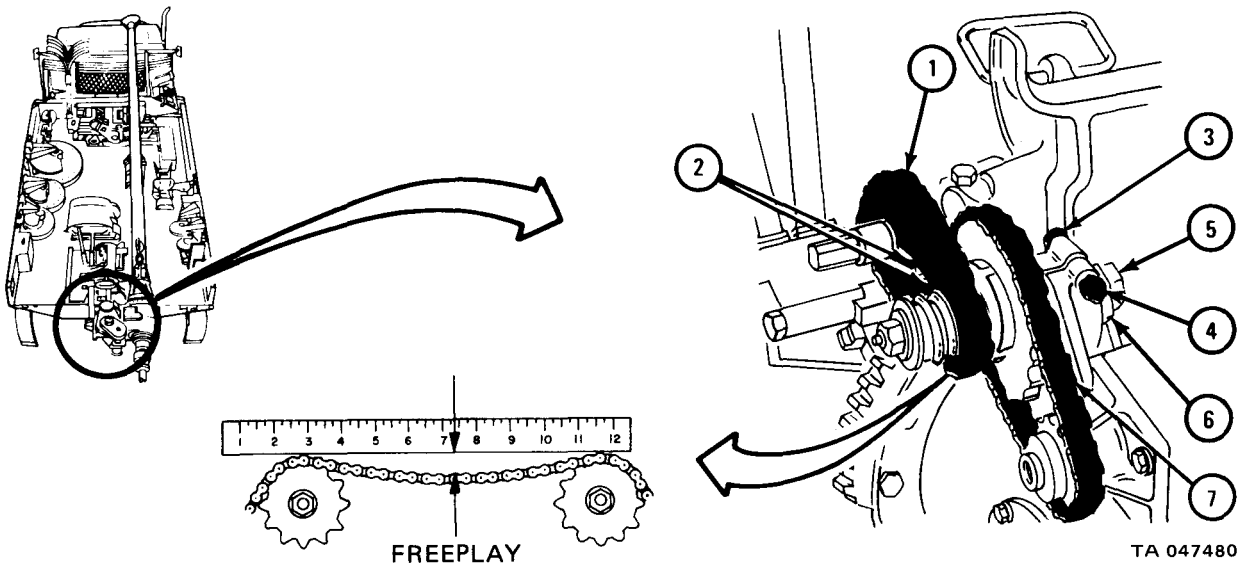

18-81. ROLLER DRIVE CHAIN REPAIR.

TOOLS : Grinder

SUPPLIES : Removable connecting link

PERSONNEL: One

EQUIPMENT CONDITION : Truck parked, engine off, handbrake set.

a. Preliminary Procedures.

- (1) Remove horizontal leveling worm drive chain. Refer to para 18-78.
- (2) Remove rear winch drive chain. Refer to Part 4, para 19-13.
- (3) Remove reduction drive chain. Refer to Part 4, para 19-17.
- (4) Remove vertical leveling worm drive chain. Refer to para 18-79.

b. Repair.**FRAME 1****WARNING**

Eye shields must be worn when using grinder. Eye injury can occur if eye shields are not used.

1. Using grinder, take off damaged connecting link (1) from chain assembly (2) by grinding off two riveted ends (3) from connecting link pins (4). Take link from chain.
2. Put removable connecting link pins (5) into two ends of chain (2). Put link plate (6) onto connecting link pins.
3. Clip connector plate (7) over link plate (6) and onto link pins (5).

**NOTE**

Follow-on Maintenance Action Required:

1. Replace horizontal leveling worm drive chain. Refer to para 18-78.
2. Replace rear winch drive chain. Refer to Part 4, para 19-13.
3. Replace reduction drive chain. Refer to Part 4, para 19-17.
4. Replace vertical leveling drive chain. Refer to para 18-79.

END OF TASK

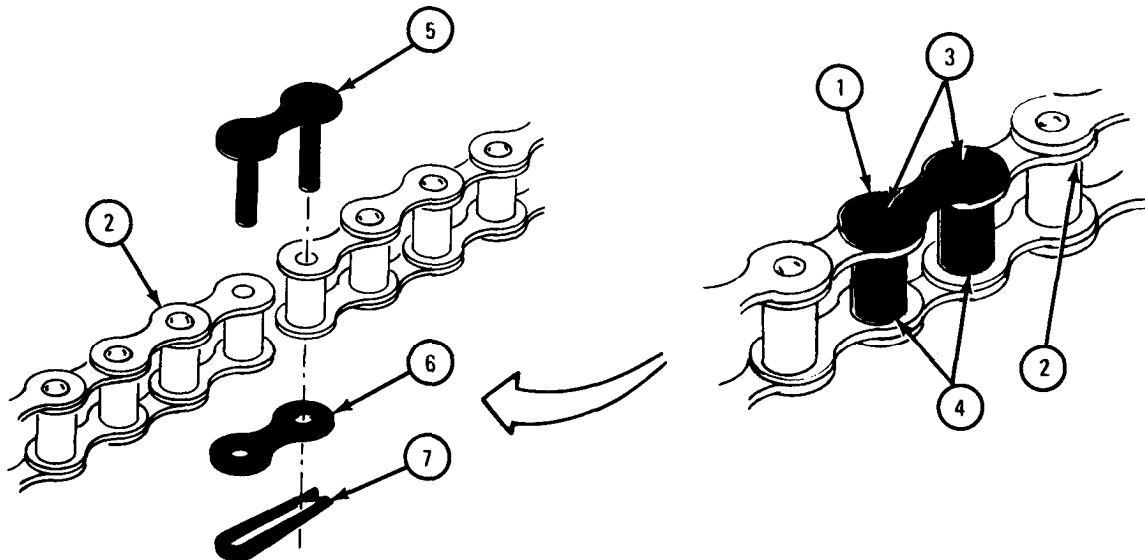

TA 047481

18-82. EARTH BORING MACHINE DRIVE SHAFT ASSEMBLY REMOVAL AND REPLACEMENT .

TOOLS : 3/4-inch open end wrench  
3/4-inch box wrench

SUPPLIES : None

PERSONNEL : One

EQUIPMENT CONDITION: Truck parked, engine off, handbrake set.

a. Removal.

FRAME 1

1. Using 3/4-inch open end wrench, hold two nuts (1). Using 3/4-inch box wrench, unscrew and take off two nuts and screws (2).
2. Let end of drive shaft (3) down slowly.
3. Using 3/4-inch open end wrench, hold four nuts (4) . Using 3/4-inch wrench, unscrew and take off four nuts and screws ( 5).
4. Take out drive shaft (3) .

END OF TASK

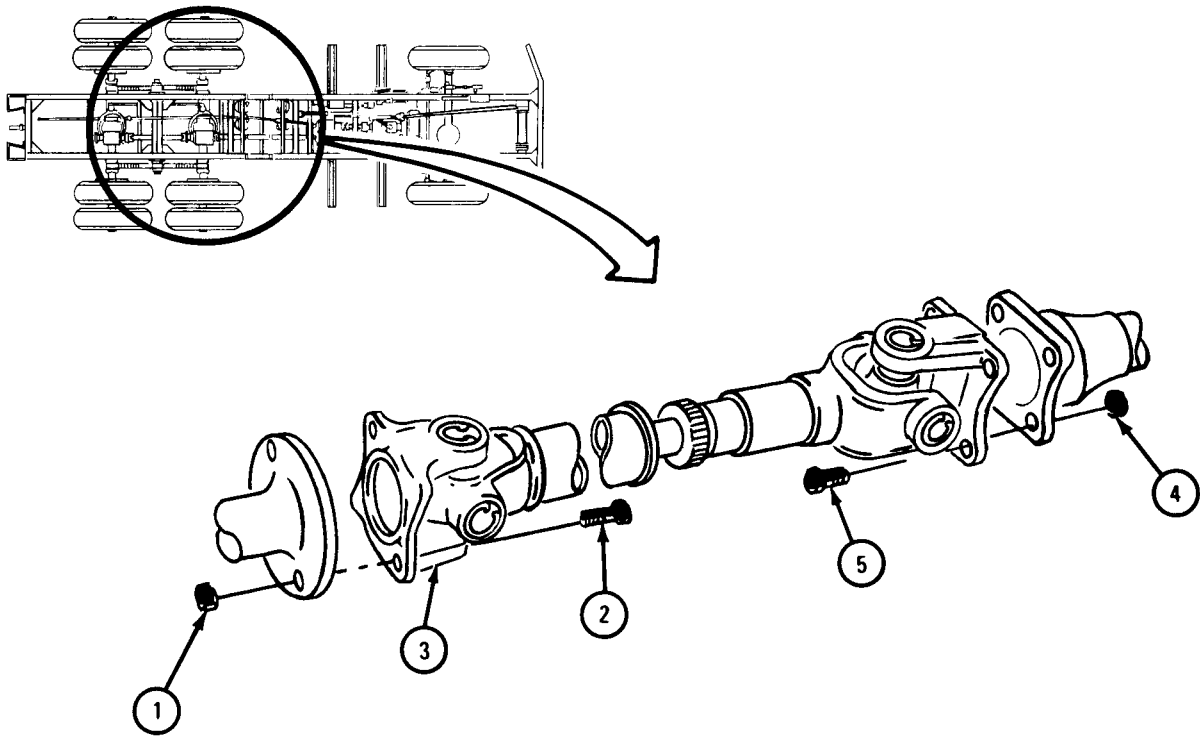

TA 047451

b. Replacement.

## FRAME 1

1. Lift one end of drive shaft (1). Aline holes in universal joint yoke (2) with those in companion flange (3).
2. Put four screws (4) through holes in universal joint yoke (2) and companion flange (3).
3. Screw on and hand tighten nuts (5) on screws (4).

GO TO FRAME 2

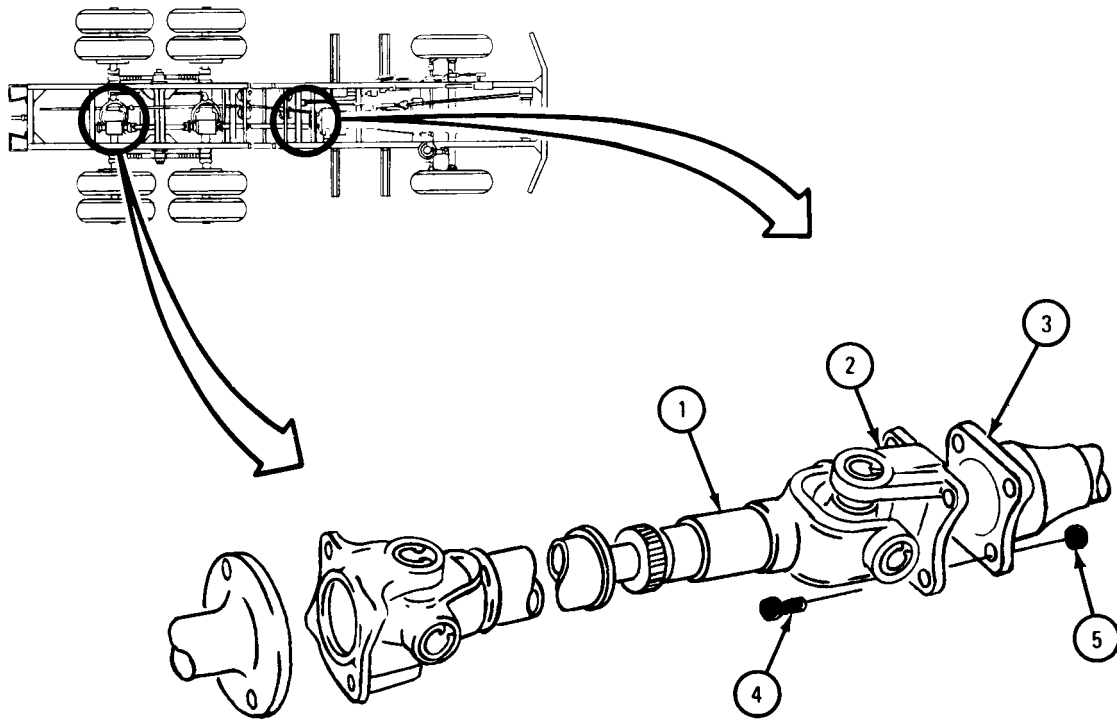

TA 047452

FRAME 2

1. Lift up other end of drive shaft (1). Aline hole in universal joint yoke (2) with those in companion flange (3).
2. Put two screws (4) through holes in universal joint yoke (2) and companion flange (3).
3. Screw on and hand tighten nuts (5) on screws (4).
4. Using 3/4-inch open end wrench, hold screws (4). Using 3/4-inch box wrench, tighten nuts (5 and 6).

END OF TASK

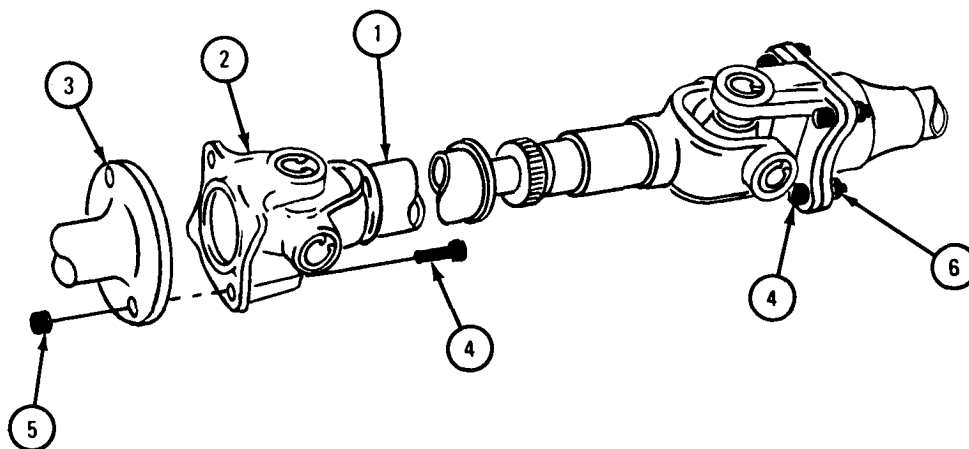

TA 047453



18-83. CAB PROTECTOR UPPER SECTION REMOVAL AND REPLACEMENT  
(TRUCK M764).

TOOLS : None

SUPPLIES : None

PERSONNEL: Two

EQUIPMENT CONDITION: Truck parked, engine off, handbrake set.

NOTE

Cab protector may be taken off using truck's rear winch and boring machine derrick.

a. Preliminary Procedures.

(1) Raise derrick from support on cab protector. Refer to TM 9-2320-209-10.

(2) Take out body stakes, bows, and wheel chocks from stowed positions.

Refer to TM 9-2320-209-10.

b. Removal.

**FRAME 1**

Soldier A 1. Pull out four pin assemblies (1).

Soldier B 2. Hook hoist sling (2) to cross bars (3) of protector upper section (4).

Soldier A 3. Using guide rope (5), guide cab protector upper section (4) while it is being lifted off of truck.

Soldier B 4. Using hoist equipment, lift cab protector upper section (4) off truck and set it on ground.

5. Take off hoist sling.

END OF TASK

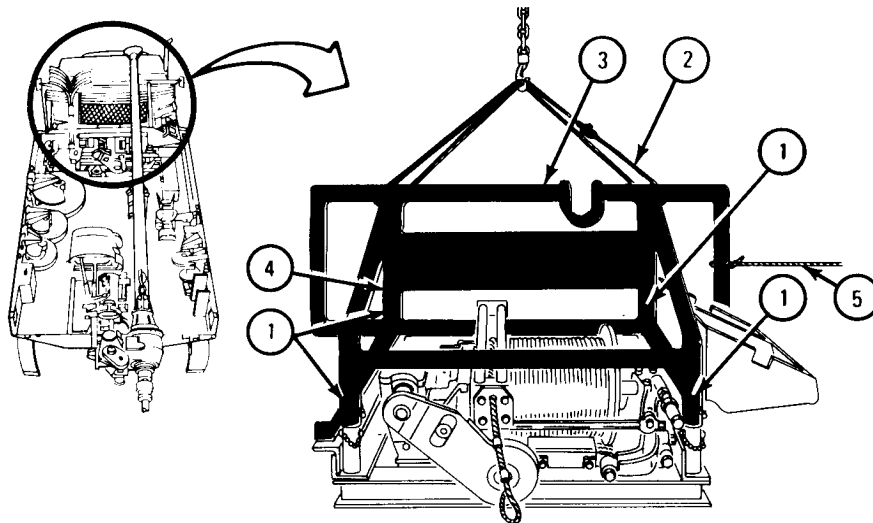

TA 047460

c. Replacement.

FRAME 1

- Soldier A 1. Put hoist sling (1) on cab protector upper section (2) as shown and join hoist equipment to sling.
2. Guide cab protector upper section (2) with rope (3) as it is lifted onto truck.
- Soldier B 3. Using hoist equipment, lift cab protector upper section (2) into place on truck.
- Soldier A 4. Push in four pin assemblies (4). Take off hoist sling.

NOTE

Follow-on Maintenance Action Required:

1. Put body stakes, bows, and wheel chocks into stowed positions. Refer to TM 9-2320-209-10.
2. Lower derrick to support on cab protector. Refer to TM 9-2320-209-10.

END OF TASK

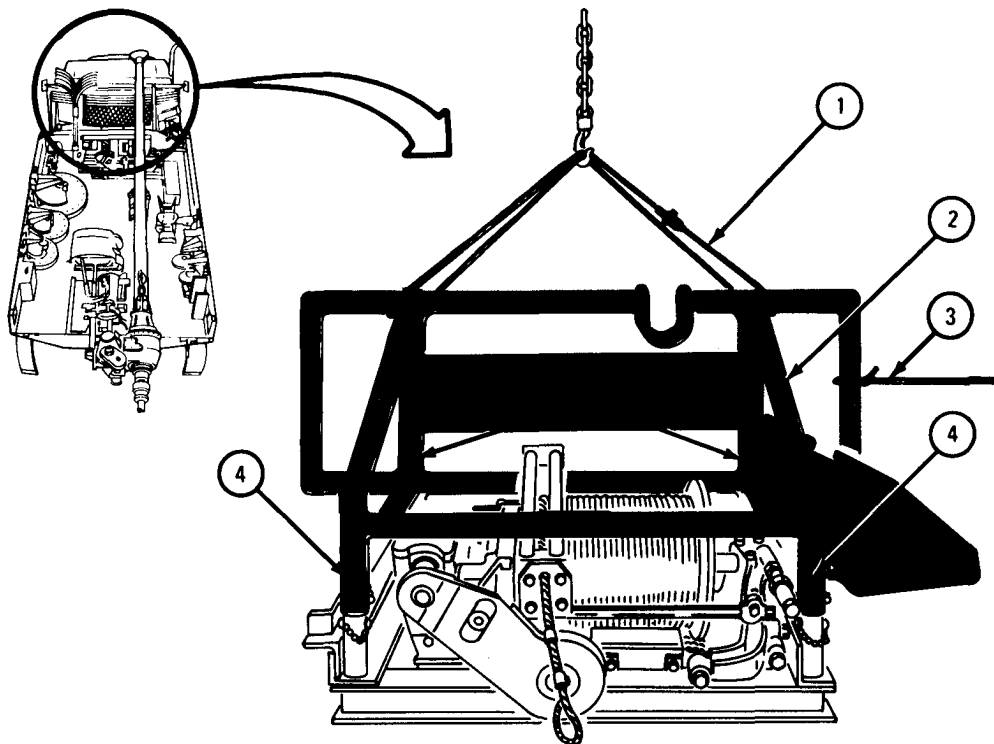

TA 047461

18-84. OUTRIGGER HYDRAULIC LINES AND FITTINGS REMOVAL AND REPLACEMENT (TRUCK M764) .

TOOLS : 9/16-inch box wrench  
9/16-inch open end wrench (2)  
11/16-inch open end wrench  
5/8-inch open end wrench  
7/8-inch open end wrench  
Diagonal cutting pliers  
1-inch wrench (2)

SUPPLIES: Plastic tiedown straps (5)

PERSONNEL: One

EQUIPMENT CONDITION : Truck parked, engine off, handbrake set.

a. Preliminary Procedure. Drain hydraulic tank. Refer to LO 9-2320-209-12/1.

b. Removal.

FRAME 1

1. Working under truck and using diagonal cutting pliers, cut and take off five plastic tiedown straps (1). Throw away plastic tiedown straps.
2. Using 9/16-inch wrenches, unscrew and take off nut (2) and screw (3). Take off two clamps (4).

GO TO FRAME 2

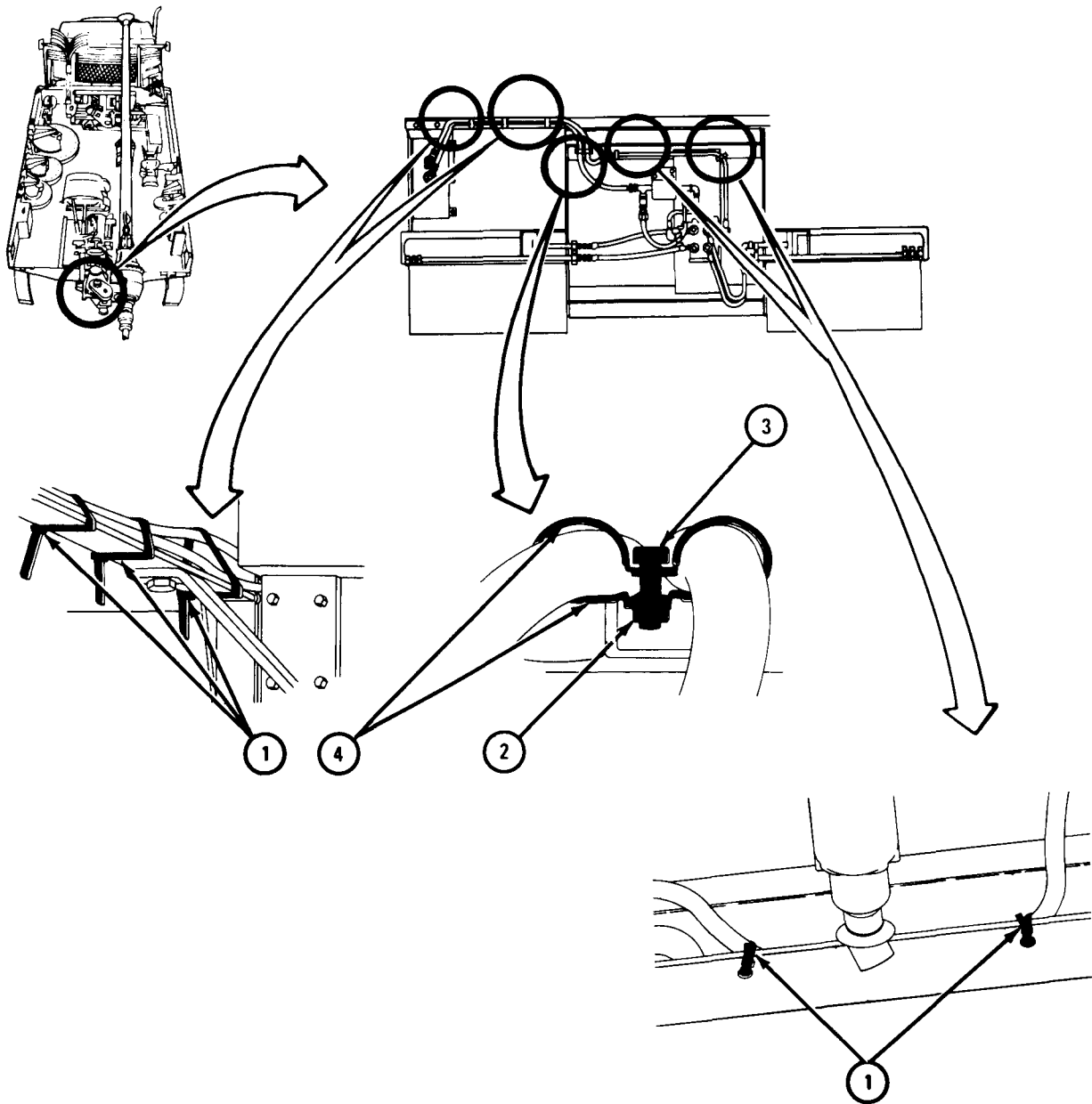

TA 085078

## FRAME 2

1. Working above left rear wheels and using 9/16-inch wrenches, take out two screws (1), two nuts (2), and cover (3).

GO TO FRAME 3

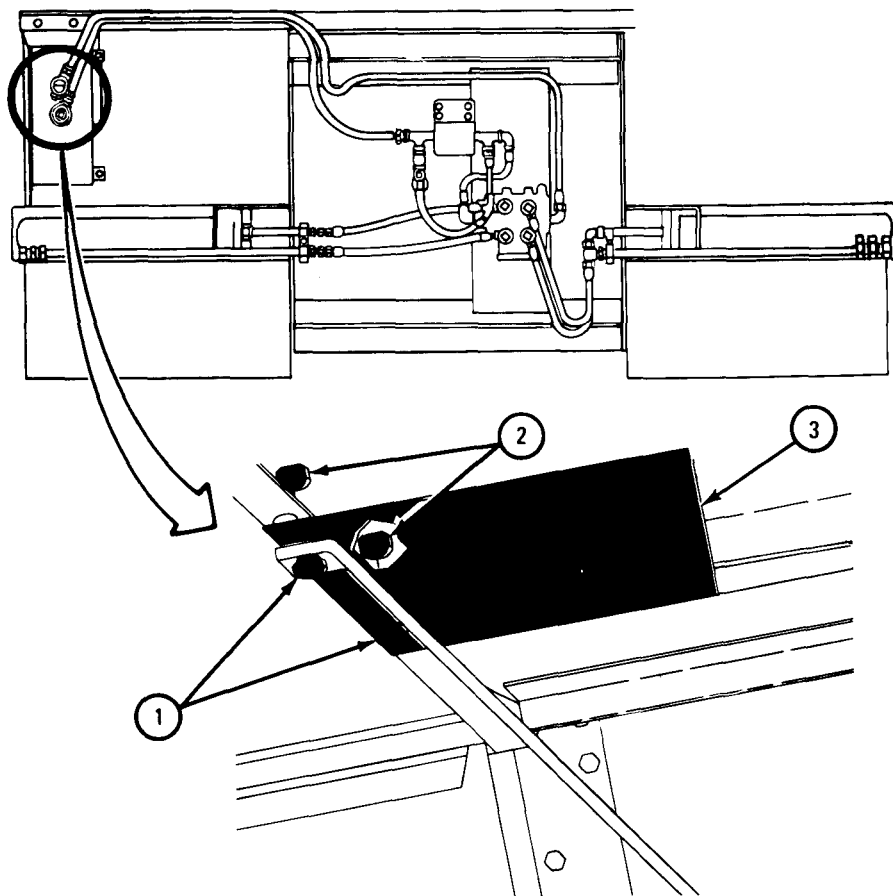

TA 101600

FRAME 3

1. Working under truck and using 1-inch wrenches, unscrew and take off hose assembly fitting (1) from pump fitting (2).
2. Working above left rear wheel and using 1-inch wrenches, unscrew and take off hose assembly fitting (3) from tank fitting (4). Take out hose assembly (5).

GO TO FRAME 4

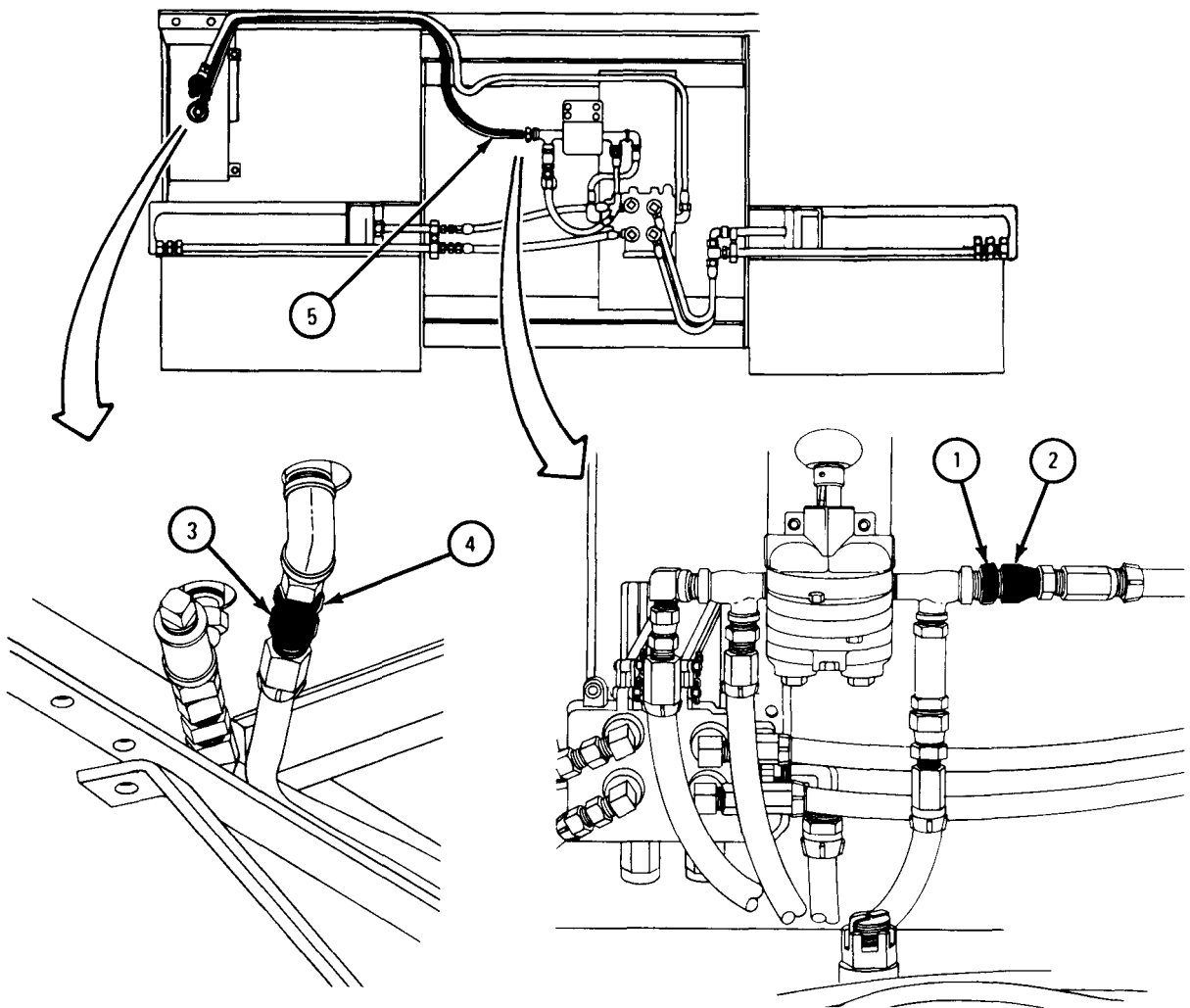

TA 085079

## FRAME 4

1. Using 1-inch wrenches, unscrew and take off hose assembly fitting (1) from valve control fitting (2).
2. Using 1-inch wrenches, unscrew and take off hose assembly fitting (3) from tank fitting (4). Take out hose assembly (5).

GO TO FRAME 5

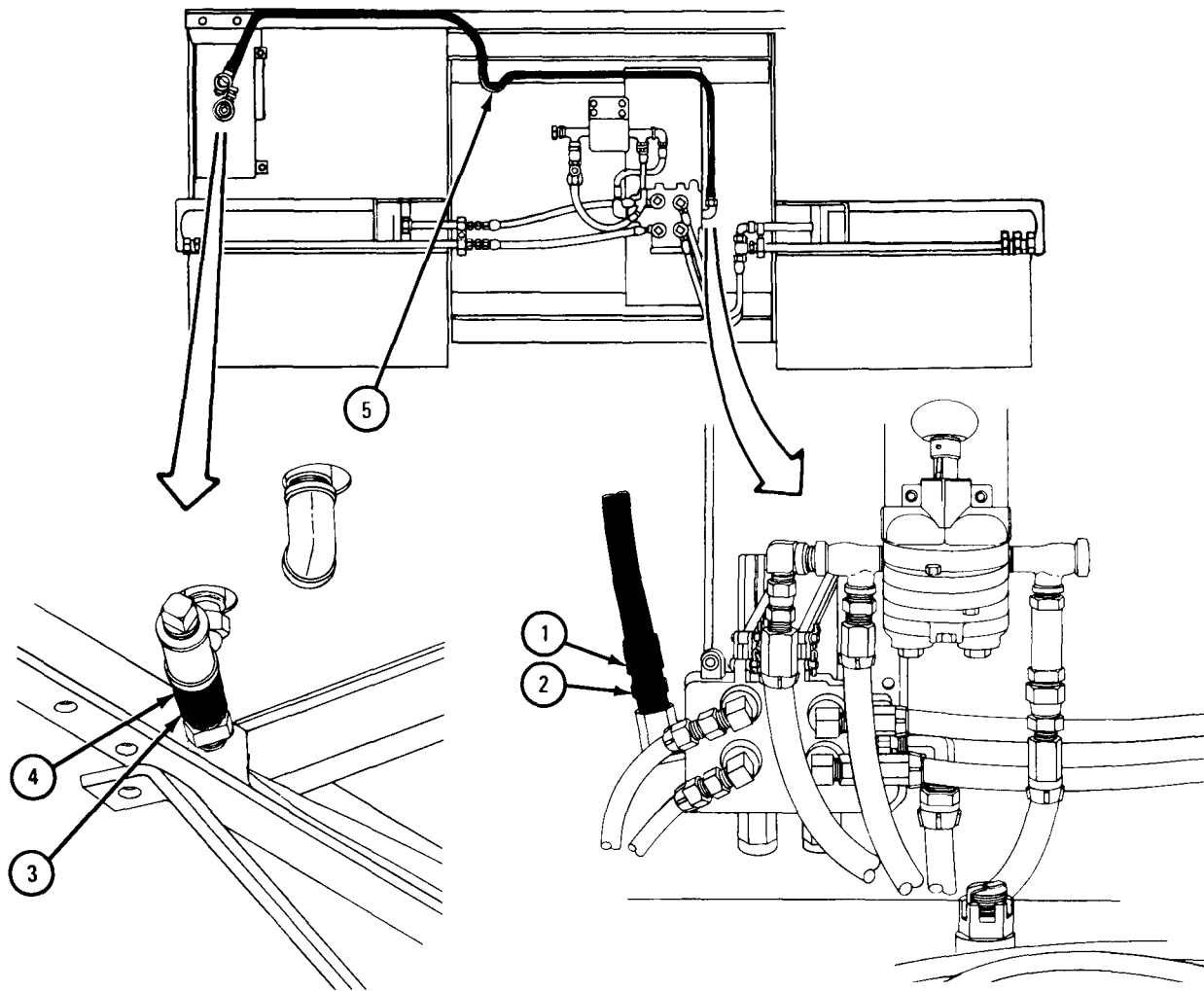

TA 085081

**FRAME 5**

1. Using 7/8-inch wrenches, unscrew and take off hose assembly fitting (1) from pump fitting with check valve (2).
2. Using 7/8-inch wrenches, unscrew and take off hose assembly fitting (3) from pump fitting (4). Take out hose assembly (5).

GO TO FRAME 6

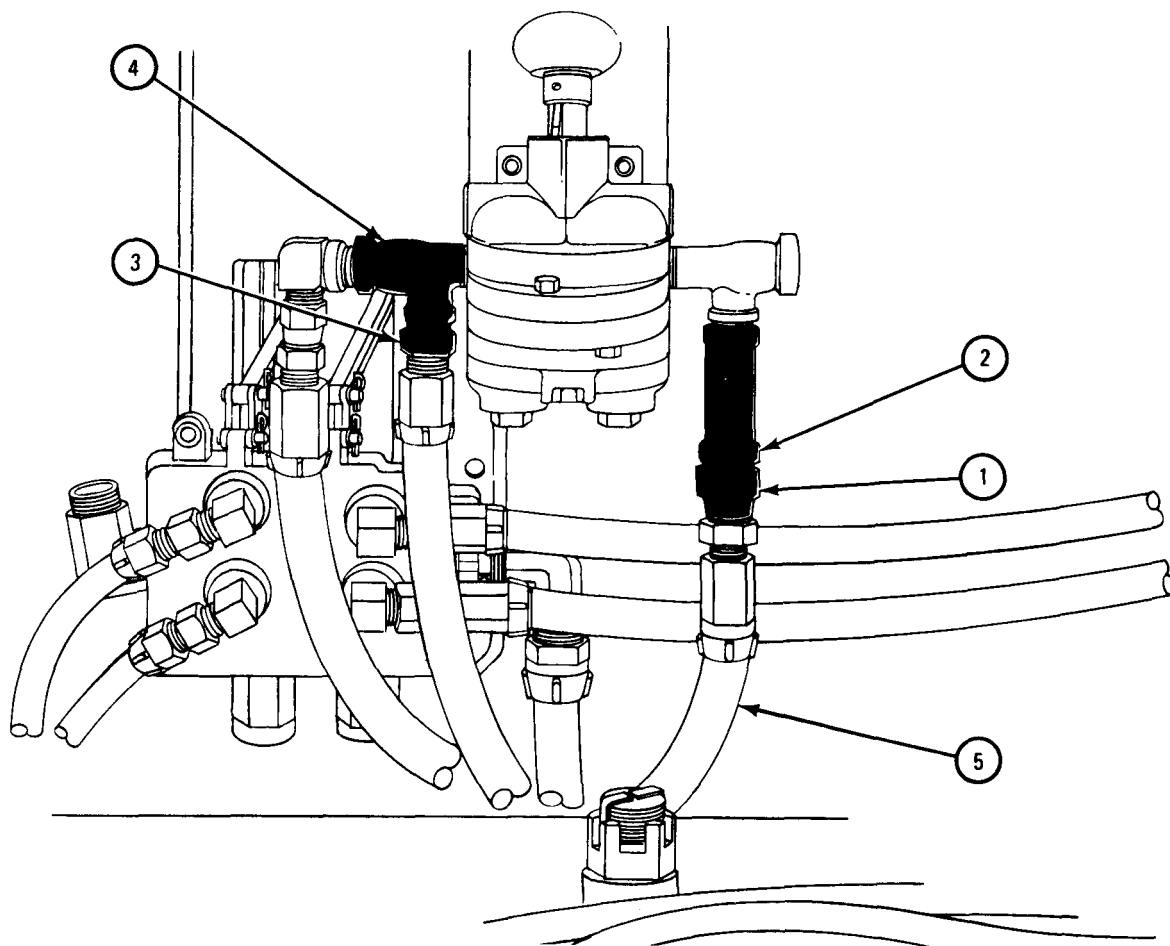

TA 085082



## FRAME 6

1. Using 1-inch wrenches, unscrew and take off hose assembly fitting (1) from pump fitting (2).
2. Using 1-inch wrenches, unscrew and take off hose assembly fitting (3) from valve fitting (4). Take out hose assembly (5).

GO TO FRAME 7

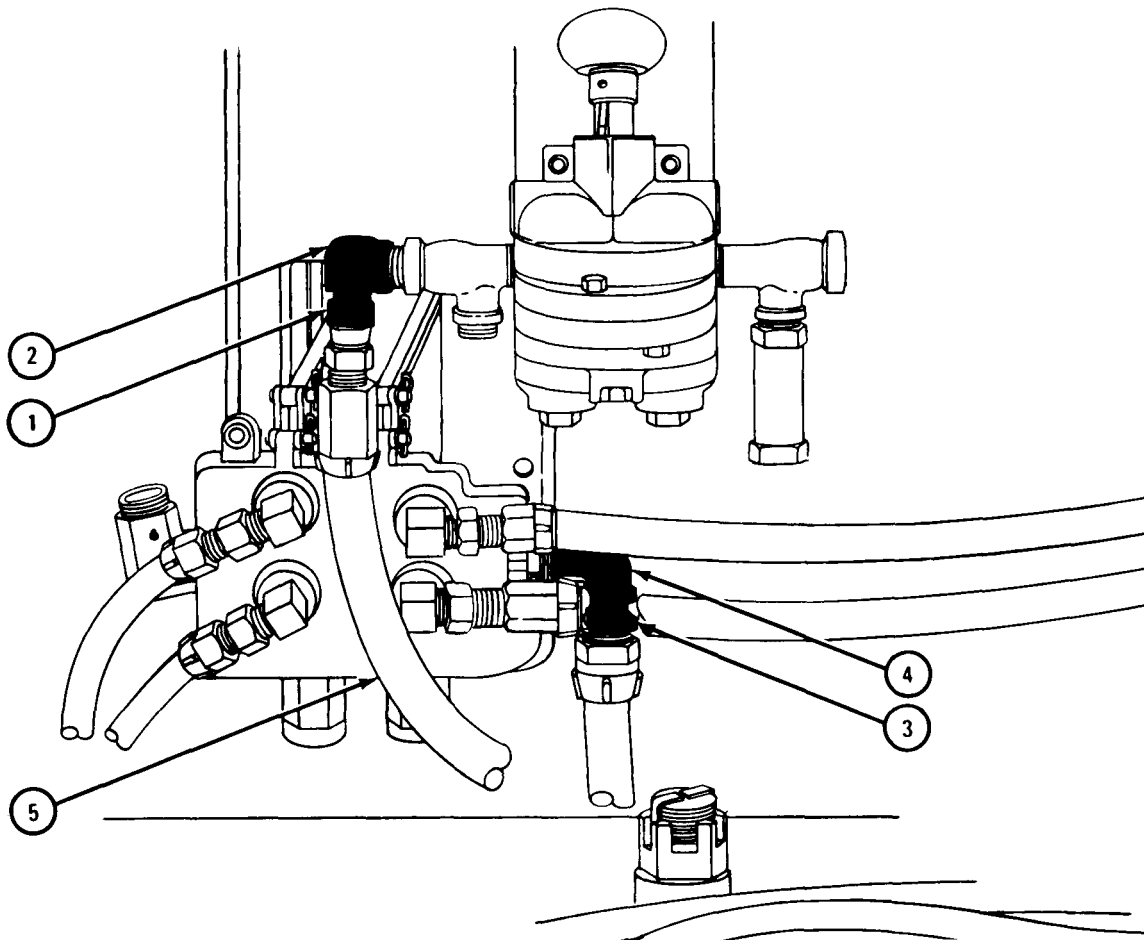

TA 085083

FRAME 7

NOTE

Steps 1 and 2 are shown for the left outrigger hydraulic cylinder connection. These steps are the same for the right outrigger hydraulic cylinder.

1. Using 11/16-inch wrenches, unscrew and take off two hose assembly fittings (1) from two valve fittings (2).
2. Using 5/8-inch wrench, hold line fitting (3). Using 11/16-inch wrench, unscrew fitting (4) from two couplings (5). Take out hose assemblies (6).

END OF TASK

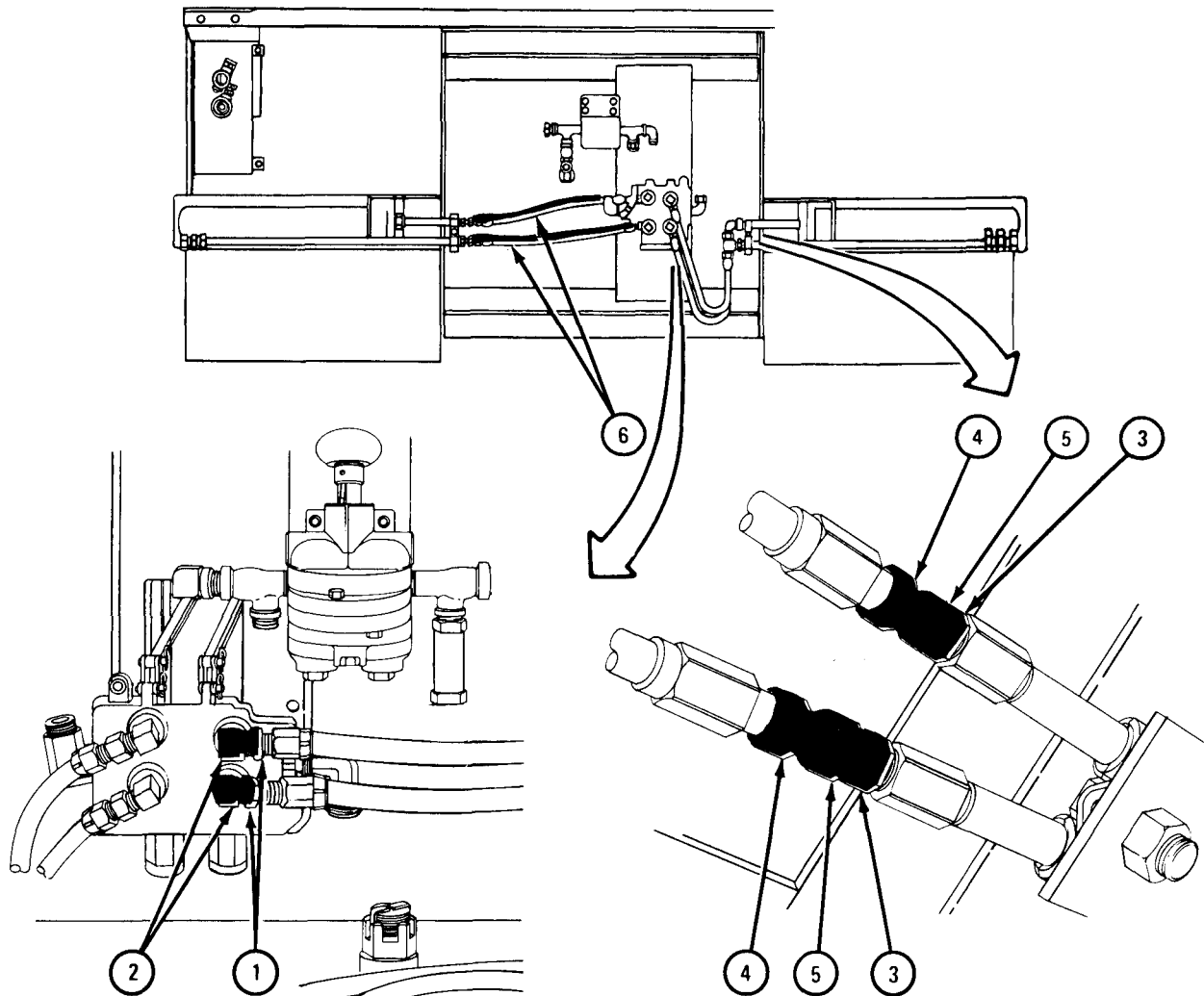

TA 085084

a. Replacement.

**FRAME 1**

CAUTION

Do not overtighten hose assembly fittings. Finger tighten adapters, then using wrench, tighten 1/8 turn more.

1. Working under truck, put in hose assemblies (1 and 2).
2. Using 5/8-inch wrench, hold line fitting (3). Using 11/16-inch wrench, screw on and tighten two fittings (4) to two couplings (5).
3. Using 11/16-inch wrenches, screw on and tighten hose assembly fittings (6) to valve fittings (7).

GO TO FRAME 2

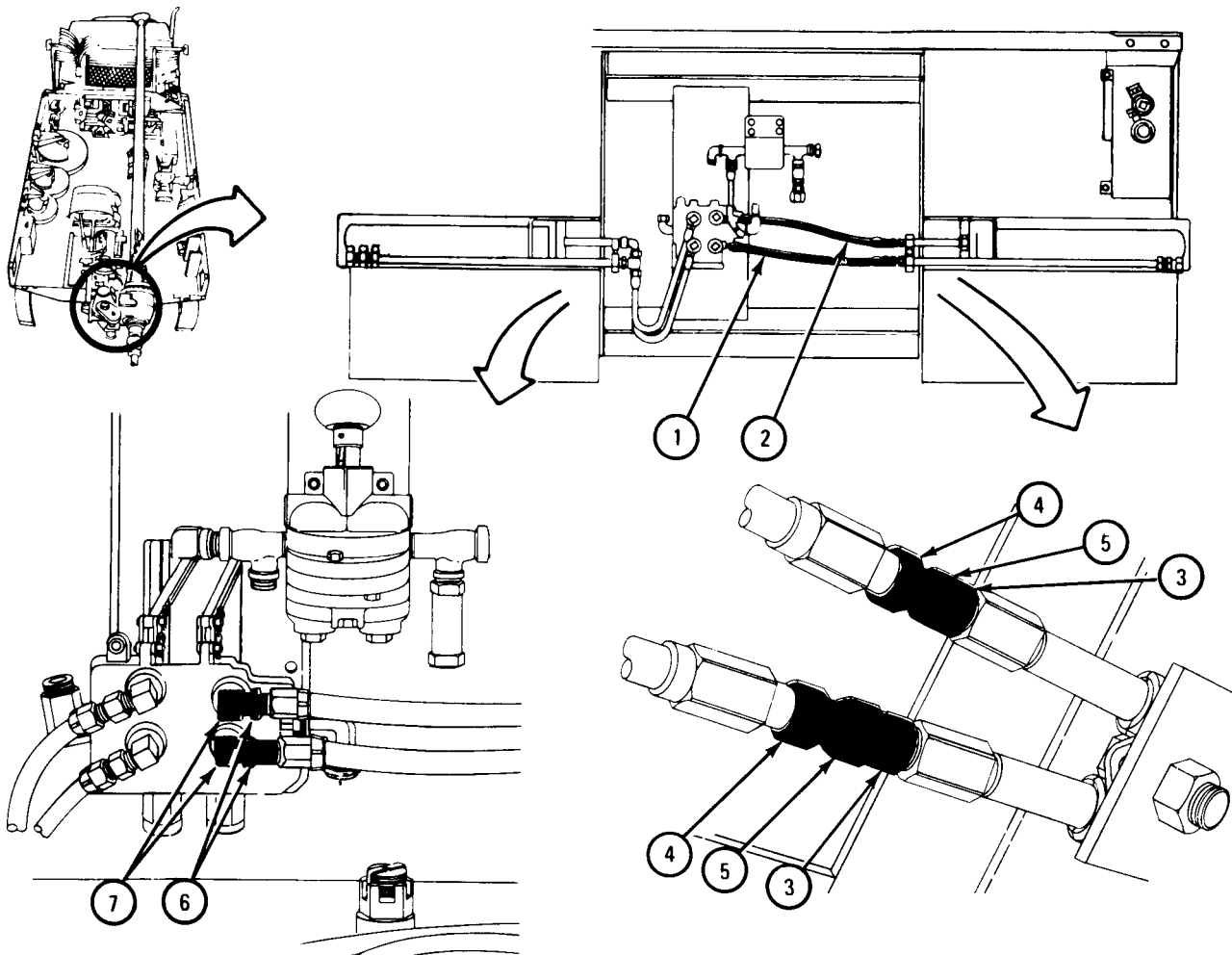

TA 085085

FRAME 2

1. Using 1-inch wrenches, screw on and tighten hose assembly fitting (1) to pump fitting (2).
2. Using 1-inch wrenches, screw on and tighten hose assembly fitting (3) to valve fitting (4).

GO TO FRAME 3

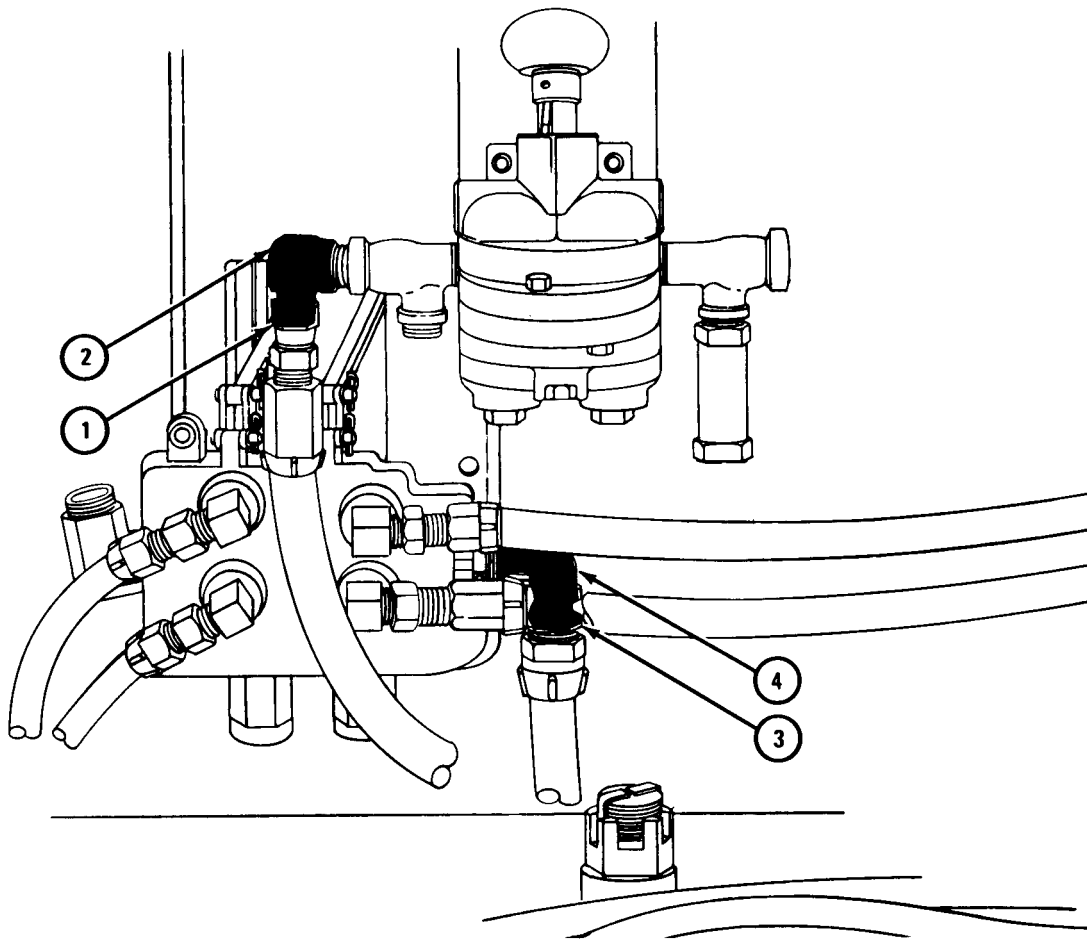

TA 085086

**FRAME 3**

1. Using 7/8-inch wrenches, screw on and tighten hose assembly fitting (1) to pump fitting with check valve (2).
2. Using 7/8-inch wrenches, screw on and tighten hose assembly fitting (3) to pump fitting (4).

GO TO FRAME 4

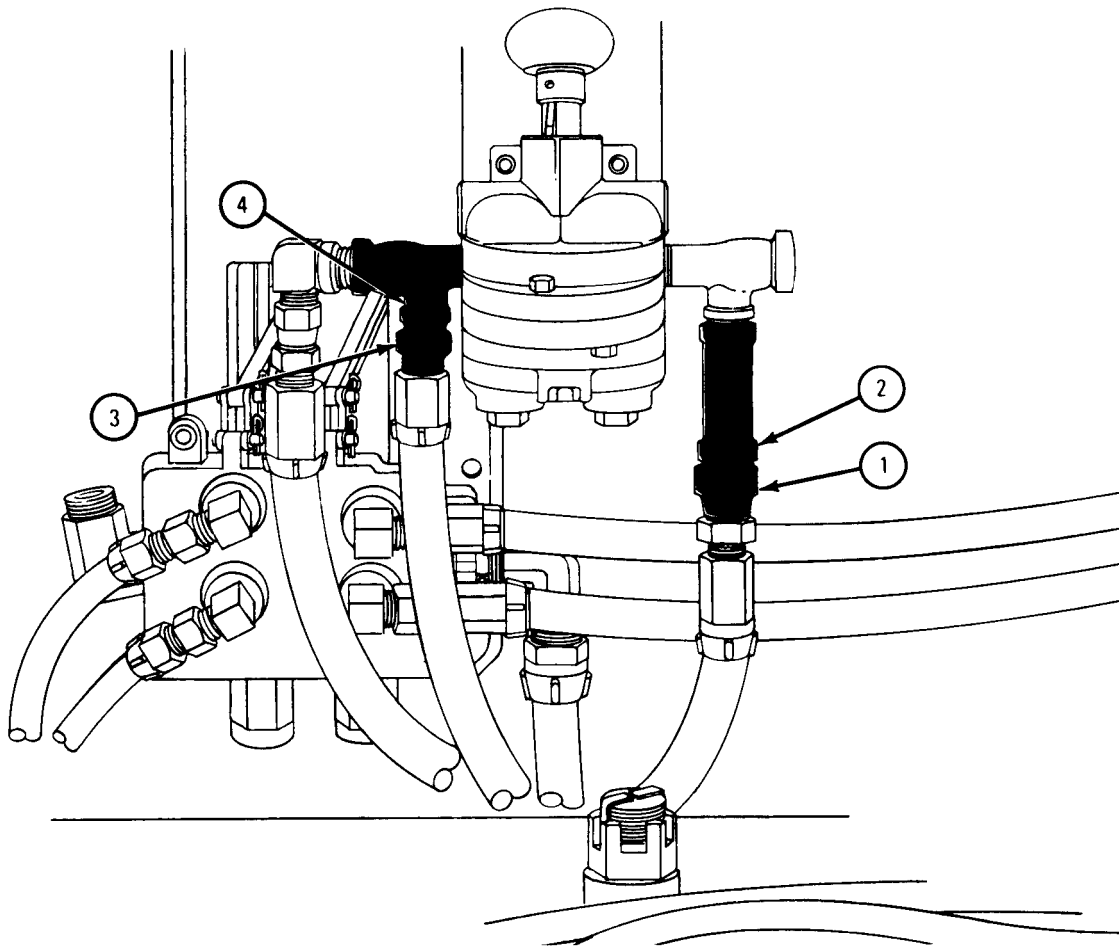

TA 085087

FRAME 4

1. Using 1-inch wrenches, screw on and tighten hose assembly fitting (1) to valve control fitting (2).
2. Using 1-inch wrenches, screw on and tighten hose assembly fitting (3) to tank fitting (4).

GO TO FRAME 5

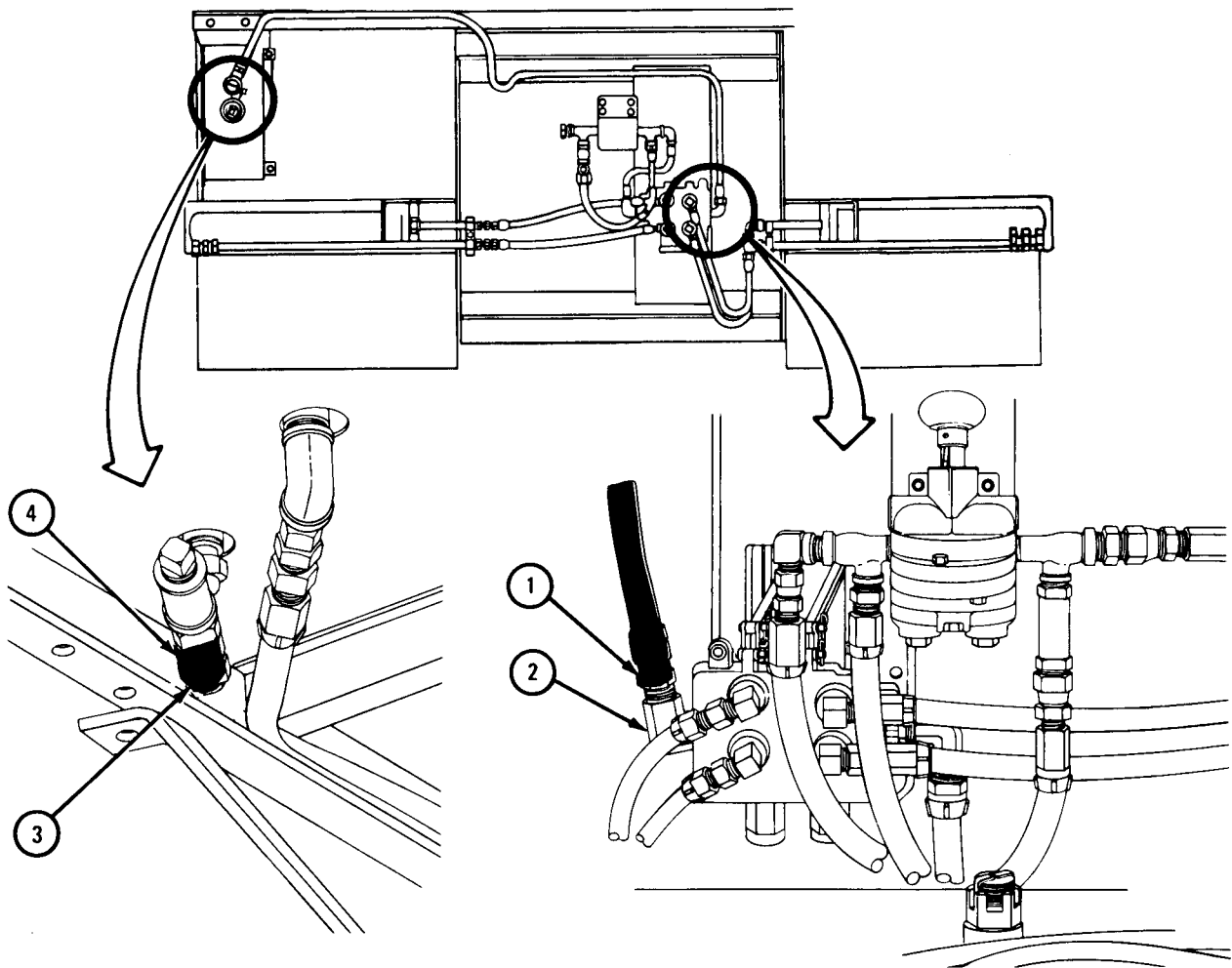

TA 085088

**FRAME 5**

1. Using 1-inch wrenches, screw on and tighten hose assembly fitting (1) to pump fitting (2).
2. Using 1-inch wrenches, screw on and tighten hose assembly fitting (3) to tank fitting (4).

GO TO FRAME 6

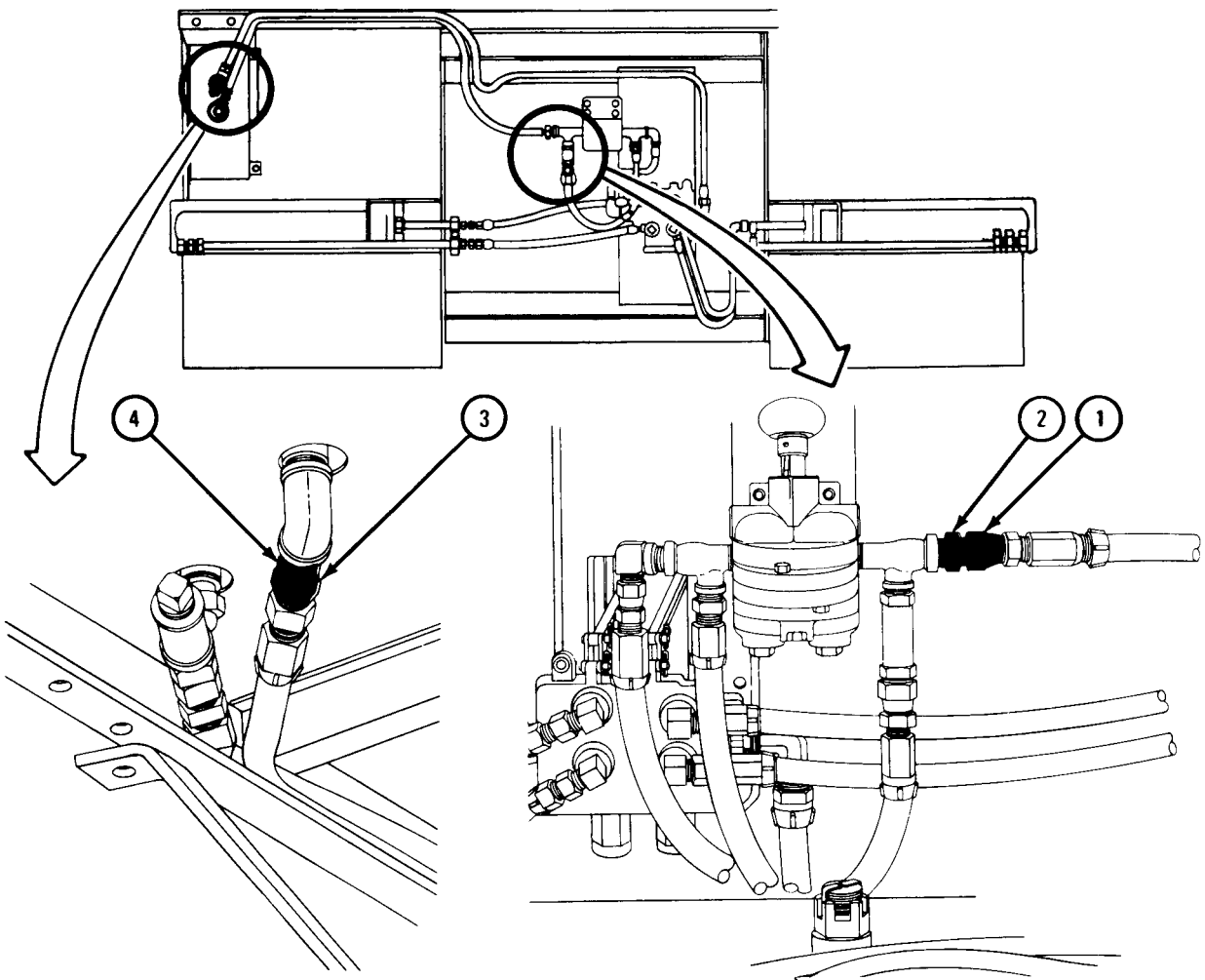

TA 085090

FRAME 6

1. Put two clamps (1) in place as shown. Using 9/16-inch wrenches, screw in and tighten screw (2) and nut (3).
2. Using pliers, put three plastic tiedown straps (4) in place as shown.

GO TO FRAME 7

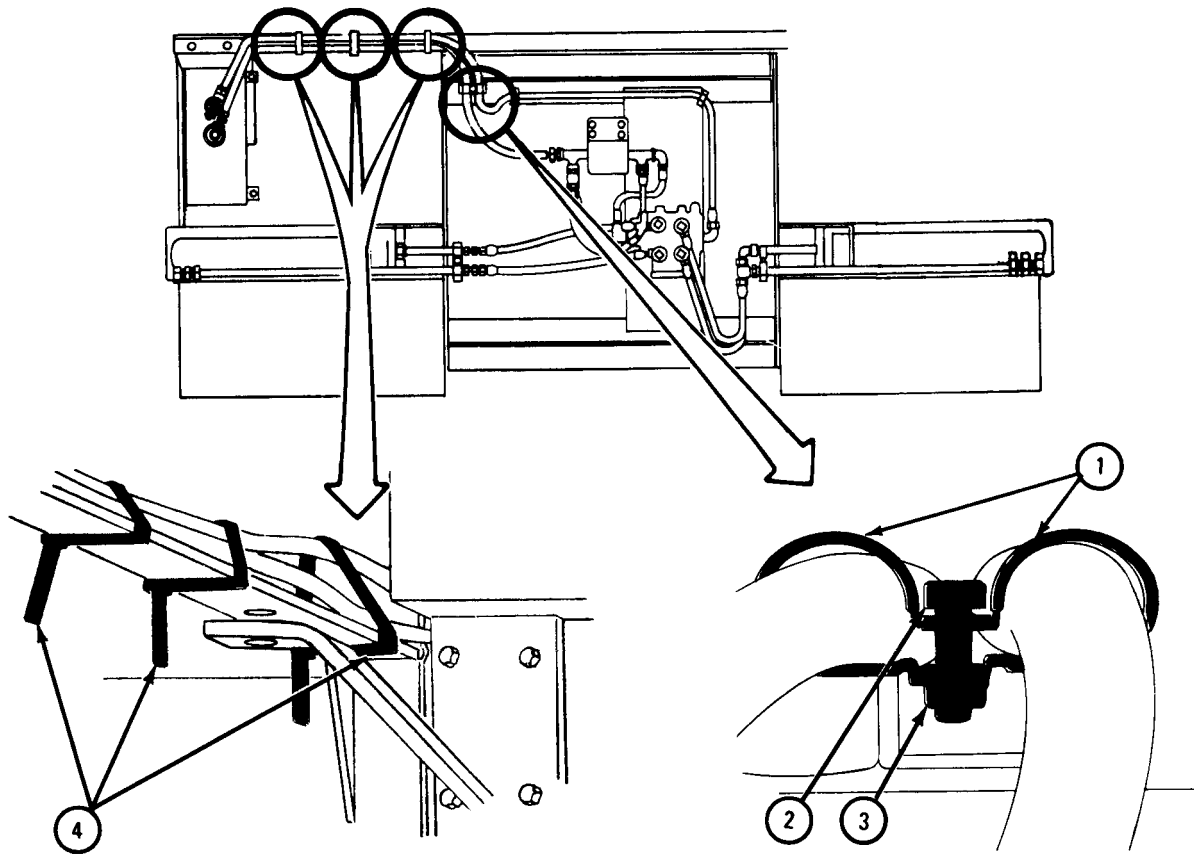

TA 085091



FRAME 7

1. Using pliers, put two plastic tiedown straps (1) in place as shown.  
GO TO FRAME 8

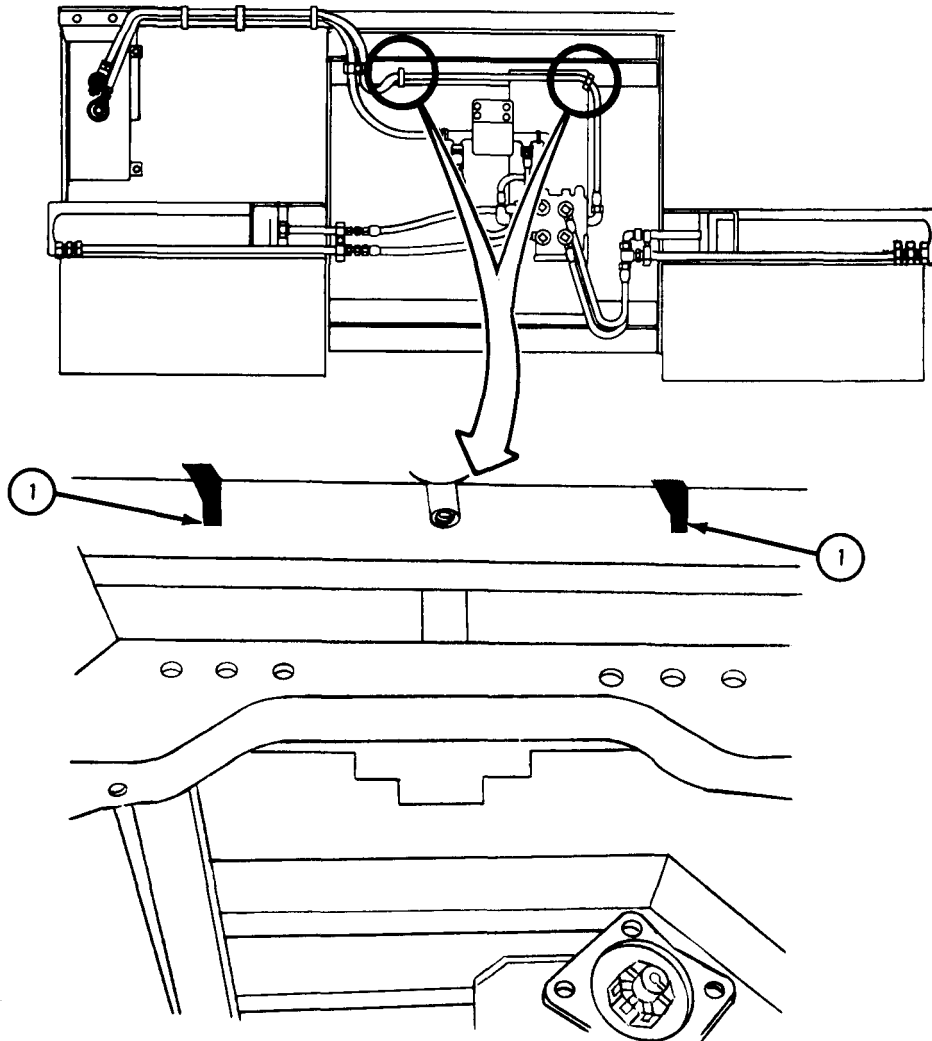

TA 085080

FRAME 8

1. Put on cover (1) and align holes.
2. Using 9/16-inch wrenches, put in two screws (2) and nuts (3).

NOTE

Follow-on Maintenance Action Required:

1. Fill hydraulic tank. Refer to LO 9-2320-209-12/1.
2. Check oil level and fill hydraulic tank if needed. Refer to LO 9-2320-209-12/1.

END OF TASK

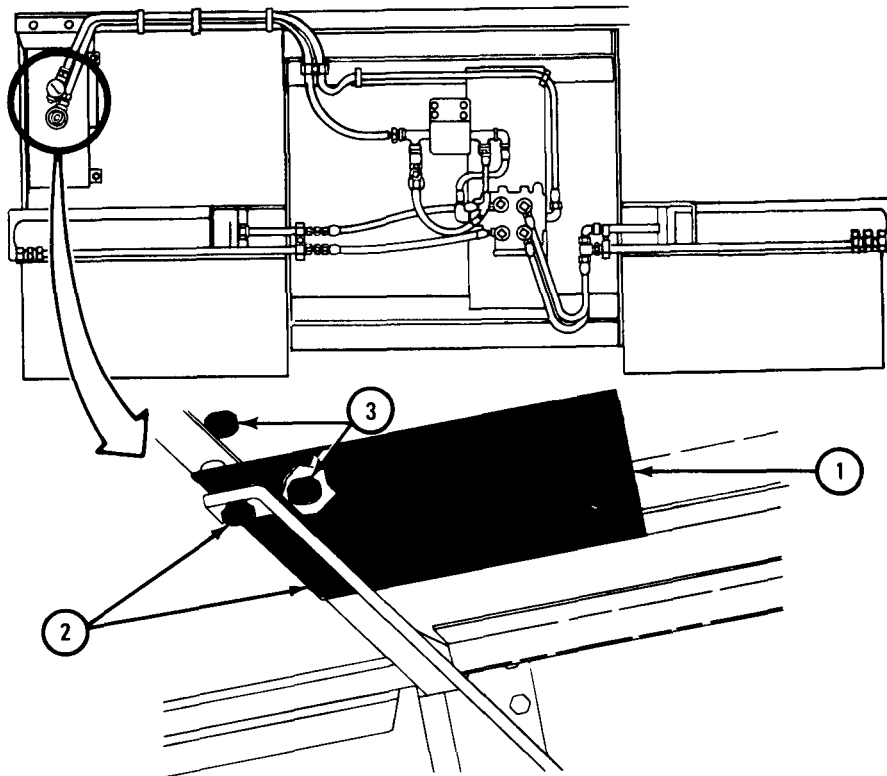

TA 101631

## 18-85. OUTRIGGER HYDRAULIC PUMP REMOVAL AND REPLACEMENT (TRUCK M764) .

TOOLS : 1-inch wrench  
 9/16-inch wrench (2)  
 3/32-inch sockethead key (Allen wrench or equivalent)  
 14-inch pipe wrench  
 7/8-inch wrench

SUPPLIES: Clean 5-gallon container  
 Lubricating oil, OE/HDO 10, MIL-L-2104  
 Caps

PERSONNEL : One

EQUIPMENT CONDITION : Truck parked, engine off, handbrake set.

a. Removal.

## FRAME 1

1. Using 9/16-inch wrench, unscrew and take off cap screw and nut (1) that join hydraulic tank fitting shield (2) to body cross sill (3). Loosen other capscrew (4) and turn shield out from under drain plug (5).
2. Using 9/16-inch wrench, unscrew and take off drain plug (5) and let oil drain into clean container.

CAUTION

Do not reuse drained oil if water or dirt is in it. Tell direct support maintenance about any water or dirt in oil.

3. After oil is drained, using 9/16-inch wrench, screw in and tighten drain plug (5). Slide shield (2) under plug. Aline holes in shield with holes in cross sill (3).
4. Using 9/16-inch wrenches, screw in and tighten capscrew and nut (1) and tighten capscrew (4).

GO TO FRAME 2

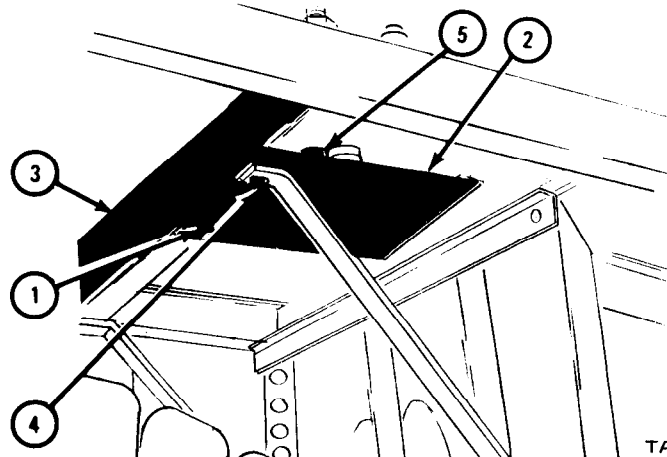
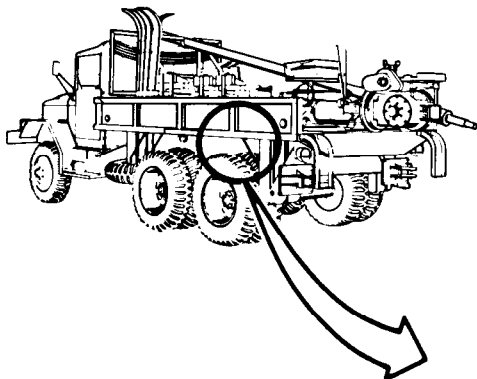

TA 047493

FRAME 2

CAUTION

Cap ends of all open hoses and fittings so that no dirt will get into hydraulic system.

NOTE

Tag all hoses so they will be put back in the same place.

1. Working under truck, using 7/8-inch wrench, unscrew and take off pump bypass hose assembly (1) from tee pipe with check valve (2) and tee pipe (3).
2. Using 1-inch wrench, unscrew and take off control valve supply hose assembly (4) and pump supply hose assembly (5).
3. Using allen wrench, unscrew and take out setscrew (6) on universal joint (7).

GO TO FRAME 3

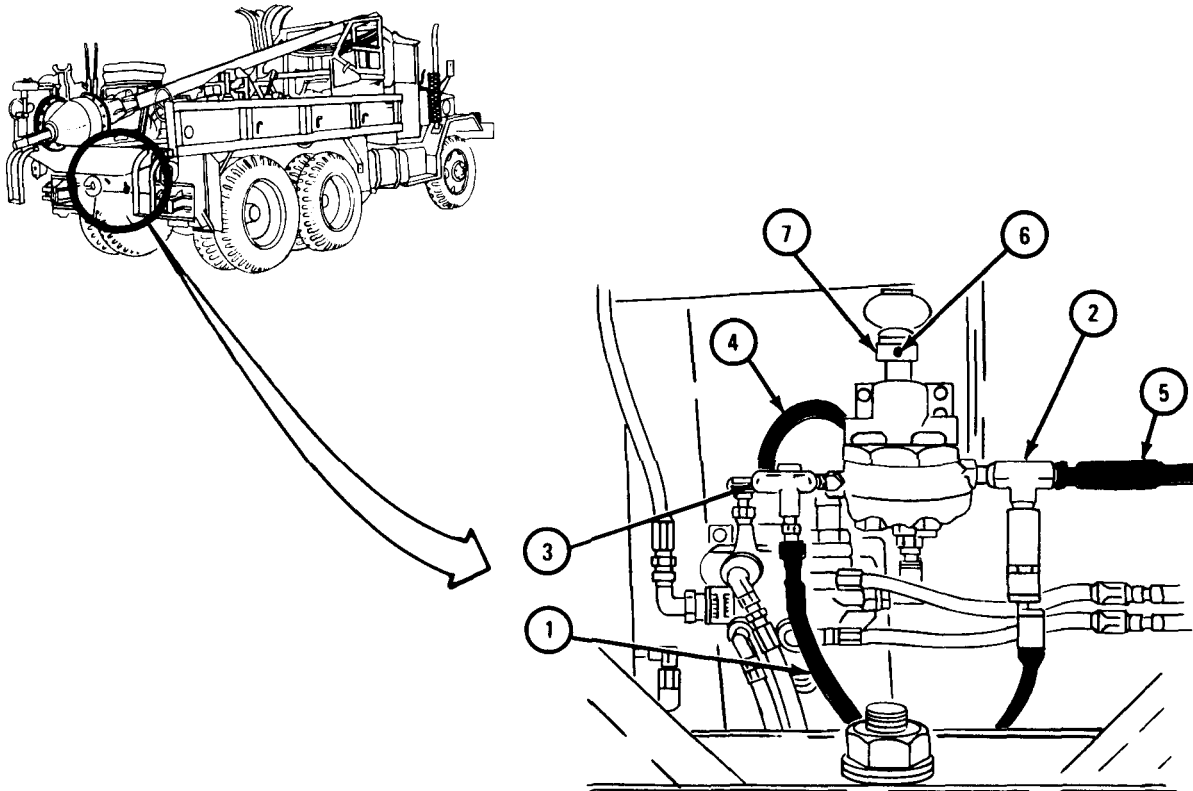

TA 047494

## FRAME 3

WARNING

When unscrewing the last of four capscrews (1) hold pump (2) so that it does not fall and cause injury.

1. Using 9/16-inch wrenches, unscrew and take off four capscrews and self-locking nuts (1). Move pump (2) away from universal joint (3), making sure key (4) does not get lost.
2. Tape key (4) to pump shaft (5) so it will not be lost.

GO TO FRAME 4

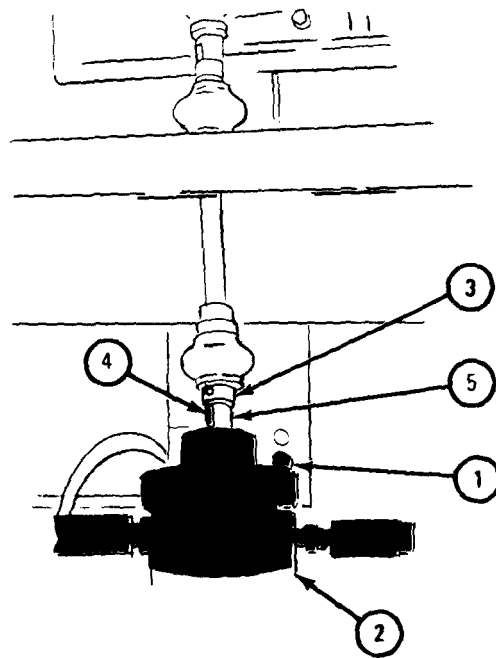

TA 047495

FRAME 4

1. Using pipe wrench , unscrew and take off tee adapter with check valve (1 ) and tee adapter (2), each with an adapter fitting (3), from pump (4).

NOTE

Do not take apart fittings and check valve.

END OF TASK

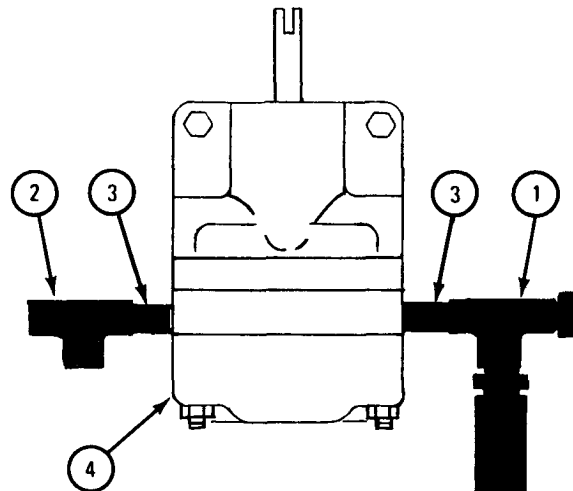

TA 047496

b. Replacement.

## FRAME 1

1. Using pipe wrench, screw in and tighten tee adapter with check valve (1) and tee adapter (2), each with an adapter fitting (3) into pump (4).

GO TO FRAME 12

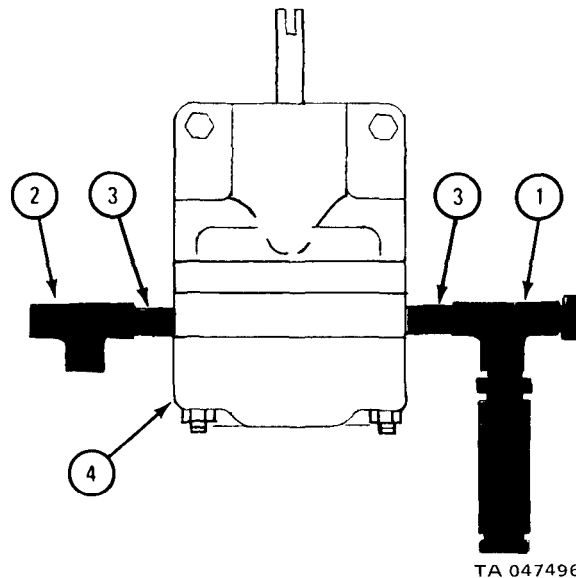

**FRAME 2**

1. Take off tape and put key (1) in place on pump shaft (2).
2. Working under truck, aline key (1) with slot in drive shaft universal joint (3) and put pump (4) in place on bracket (5).
3. Using 9/16-inch wrenches, screw in and tighten four capscrews and self-locking nuts (6).
4. Using allen wrench, screw in and tighten setscrew (7) on drive shaft universal joint (3).

GO TO FRAME 3

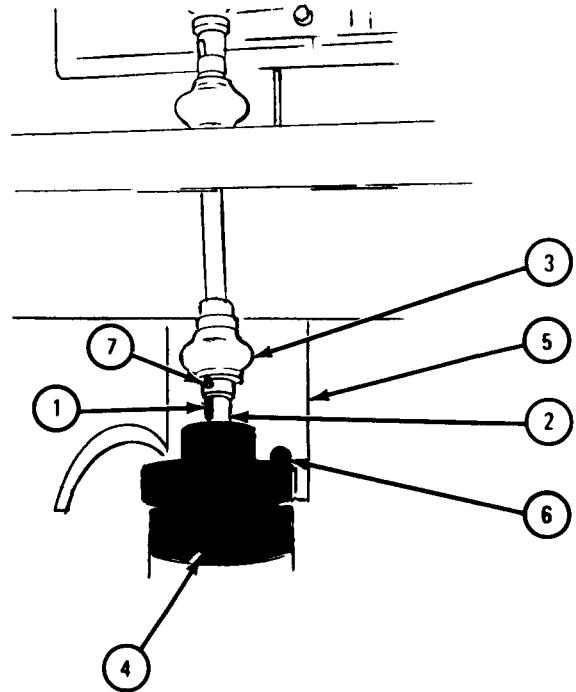
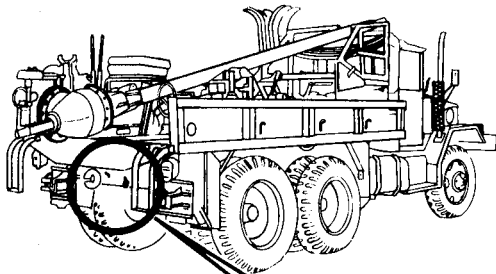

TA 047497



## FRAME 3

CAUTION

Do not overtighten hose fittings when joining hoses. Finger tighten hose adapters. Using two 1-inch wrenches, tighten fittings 1/8 turn more.

## NOTE

Take off caps from hoses and fittings before putting on hose fittings.

1. Using 1-inch wrench, screw on and tighten control valve supply hose assembly (1) to tee pipe (2) as tagged. Take off tags.
2. Using 1-inch wrench, screw on and tighten pump supply hose assembly (3) to tee pipe with check valve (4) as tagged. Take off tags.
3. Using 7/8-inch wrench, screw on and tighten pump bypass hose assembly (5) to tee pipe with check valve (4) and tee-pipe (2).

GO TO FRAME 4

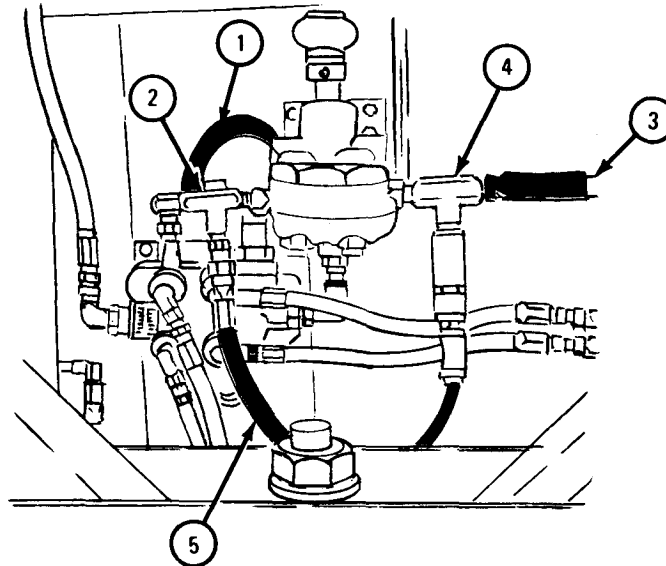

TA 047498

FRAME 4

1. Fill hydraulic tank (1) with lubricating oil to FULL mark on filler cup and gage assembly (2). Refer to LO 9-2320-209-12/1.

NOTE

Follow-on Maintenance Action Required:

1. Operate pump. Refer to TM 9-2320-209-10.
2. Check pump and hose fittings for leaks.
3. Check oil level and fill hydraulic tank again if needed. Refer to LO 9-2320-209-12/1.

END OF TASK

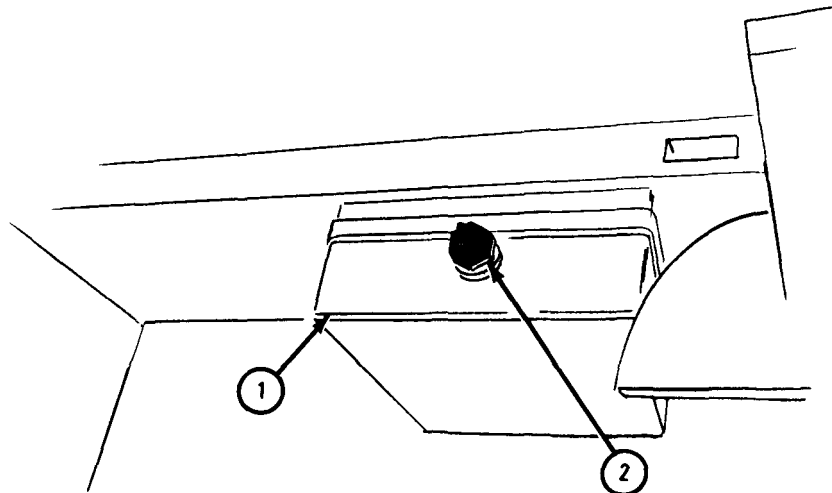
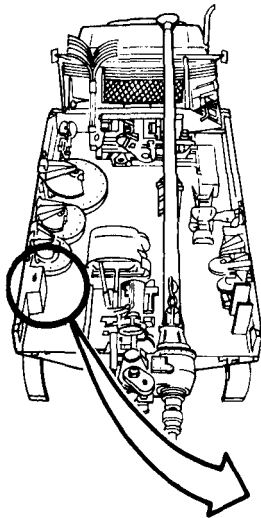

TA 047499

18-86. OUTRIGGER CONTROL VALVE REMOVAL AND REPLACEMENT (TRUCK M764).

TOOLS : Pliers  
 Flat-tip screwdriver  
 9/16-inch wrench  
 11/16-inch wrench  
 7/8-inch wrench  
 1-inch wrench  
 1 1/16-inch wrench  
 Cross-tip screwdriver (Phillips type)

SUPPLIES : Tags  
 Caps

PERSONNEL: One

EQUIPMENT CONDITION : Truck parked, engine off, handbrake set.

- a. Preliminary Procedure. Drain hydraulic system. Refer to LO 9-2320-209-12/1.
- b. Removal.

FRAME 1

1. Using phillips screwdriver, unscrew and take out two screws (1). Take off lever cover (2).

GO TO FRAME 2

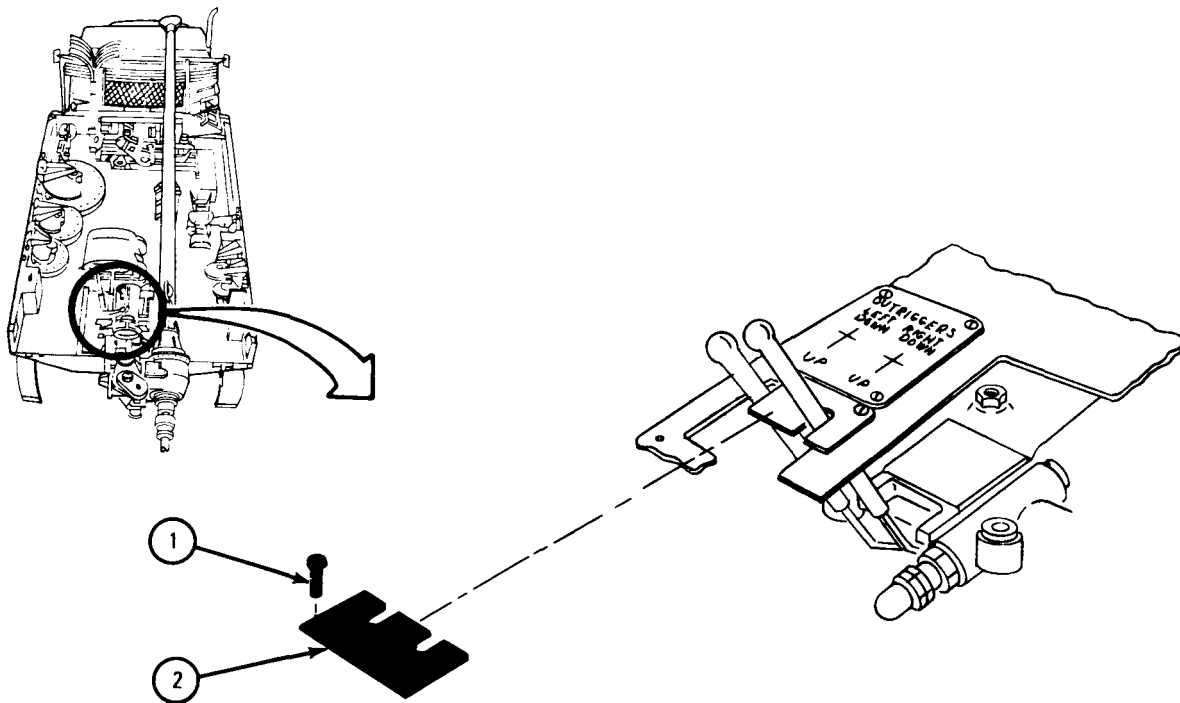

TA 101218

**FRAME 2**

1. Working under truck, using pliers, take out four cotter pins (1), two link plates (2), and two link pins (3).

2. Take out two cotter pins (4) and two pins (5) . Take out two levers (6).

GO TO FRAME 3

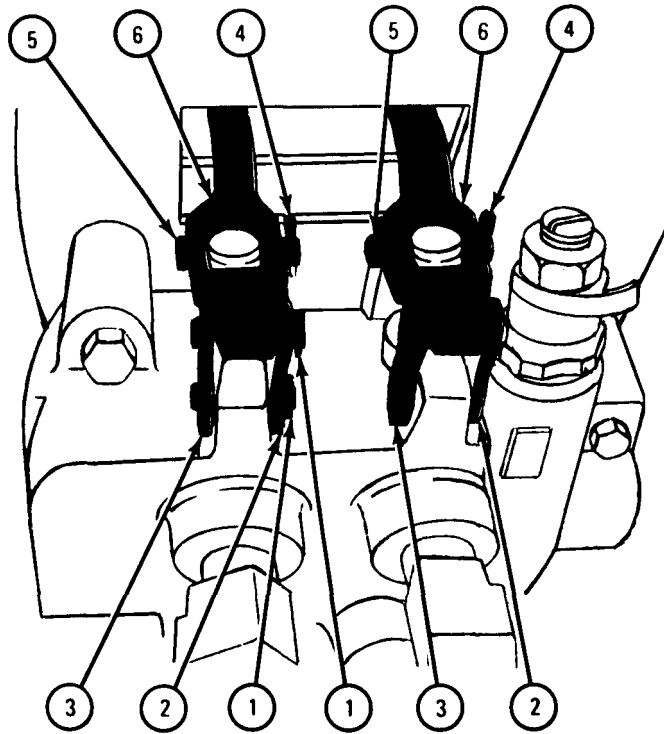

TA 047482

## FRAME 3

CAUTION

Cap all open lines and fittings to keep dirt out of hydraulic system.

1. Tag all hoses so that they will be put back in the same place.
2. Working under truck, using 11/16-inch wrench, unscrew and take off two hydraulic cylinder supply hoses (1) and two return hoses (2).
3. Using 1-inch wrench, unscrew and take off control valve-to-tank hose (3) and control valve supply hose (4).
4. Using 9/16-inch wrench, unscrew and take off three cap screws and lock-washers (5). Take off valve assembly (6).
5. Using 7/8-inch wrench, unscrew and take off four elbows (7).
6. Using 1 1/16-inch wrench, unscrew and take off two elbows (8).

END OF TASK

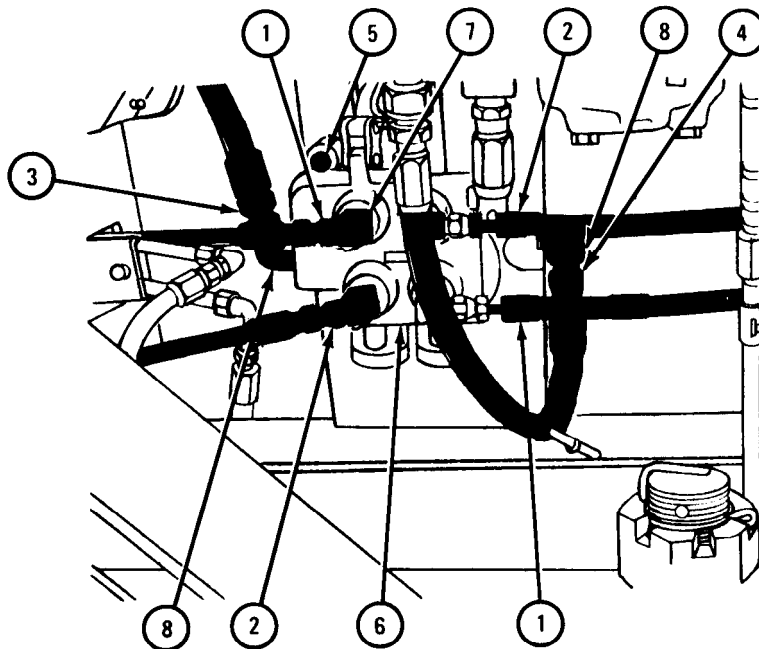

TA 047483

c. Replacement.

FRAME 1

CAUTION

Do not overtighten hose fittings when joining hoses. Finger tighten hose adapters. Using wrench, tighten 1/8 turn more.

NOTE

Take caps off hoses and fittings before putting on hose fittings.

1. Working under truck using 7/8-inch wrench, screw on and tighten four elbows (1) into control valve (2) .
2. Using 1 1/16-inch wrench, screw on and tighten two elbows (3) into control valve (2) .
3. Aline holes in control valve (2) with holes in truck body. Using 9/16-inch wrench, screw in and tighten three lockwashers and capscrews (4) .
4. Using 1-inch wrench, screw on and tighten control valve supply hose (5) and control valve-to-tank hose (6) to two elbows (3) in side of control valve assembly (2) as tagged. Take off tags.
5. Using 11/16-inch wrench, screw on and tighten two return hoses (7) and two hydraulic cylinder supply hoses (8) to four elbows (1) on bottom of valve assembly ( 2) as tagged. Take off tags.

GO TO FRAME 2

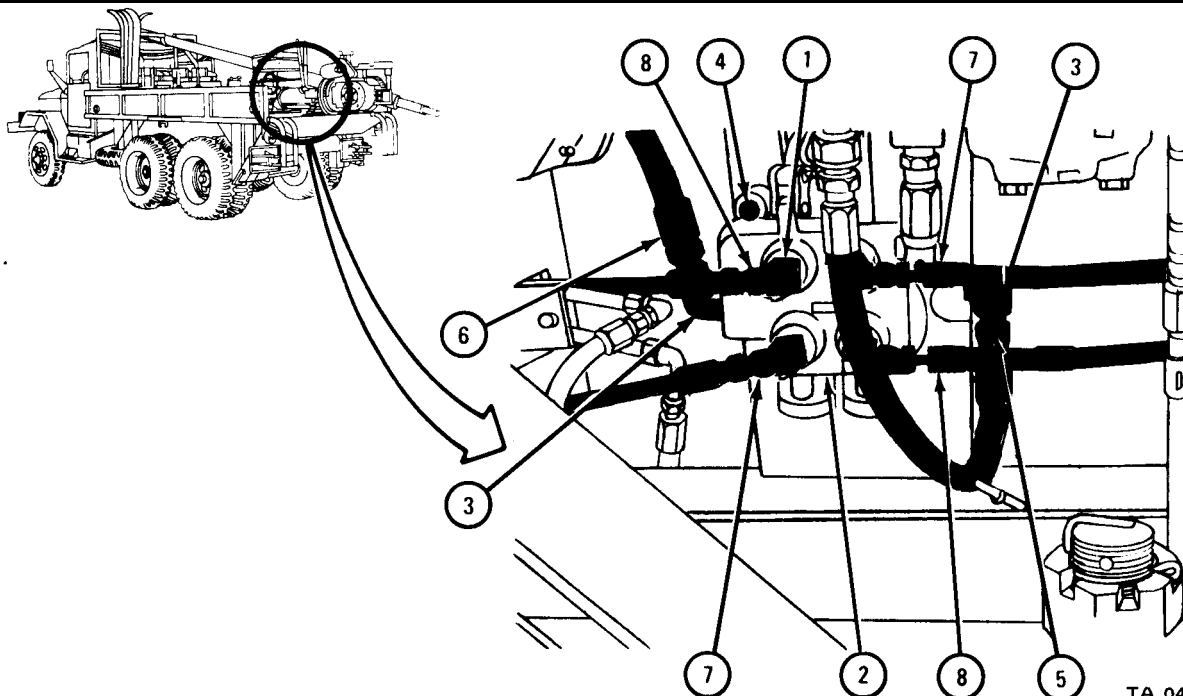

TA 047484

## FRAME 2

1. Put two control levers (1) in place. Put two pins (2) through holes in levers and control valve (3). Put two cotter pins (4) through holes in link pins.
2. Using pliers, bend open ends of cotter pins (4).
3. Put two pin links (5) in place as shown. Put on two link plates (6).
4. Using pliers, put four cotter pins (7) in holes in two pin links (5) and bend open ends of cotter pins.

GO TO FRAME 3

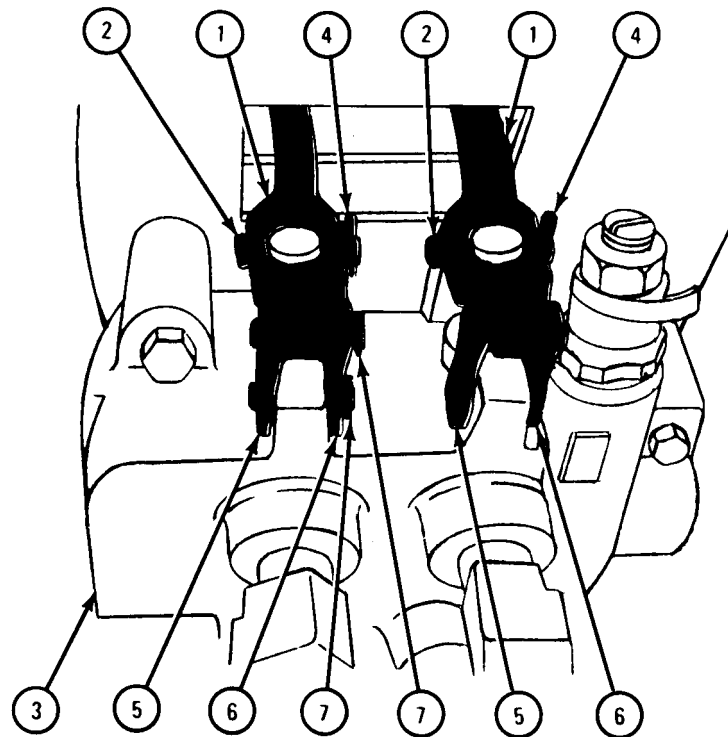

TA 047485

FRAME 3

1. Put on lever cover (1).
2. Using phillips screwdriver, screw in and tighten two screws (2).

NOTE

Follow-on Maintenance Action Required:

1. Fill hydraulic tank. Refer to LO 9-2320-209-12/1.
2. Turn on valve to get oil through system. Refer to TM 9-2320-209-10.
3. Check oil level. Fill hydraulic tank again if needed. Refer to LO 9-2320-209-12/1.

END OF TASK

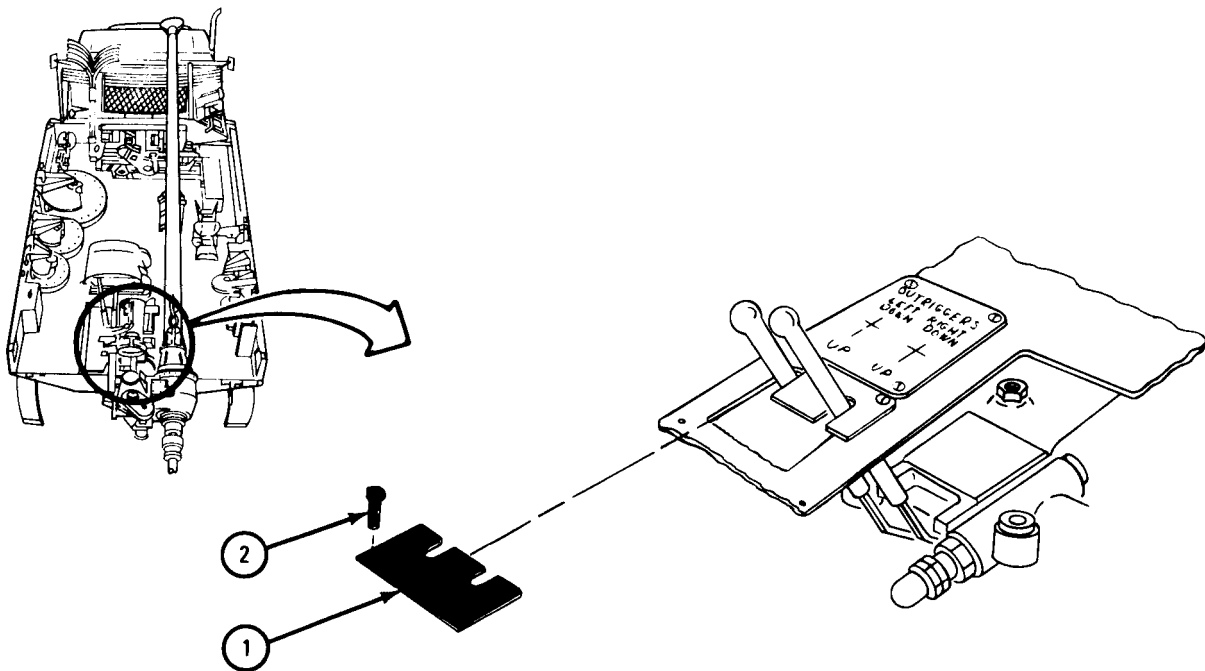

TA 085537



## 18-87. POWER LEVELER REPAIR (TRUCK M764).

TOOLS : 7/16-inch wrench

SUPPLIES : Solvent, dry cleaning, type II (SD-2) , Fed. Spec P-D-680

PERSONNEL: One

EQUIPMENT CONDITION: Truck parked, engine off, handbrake set.

a. Removal.

## FRAME 1

1. Take off three data plates (1) . Refer to Part 4, para 21-7.
2. Using 7/16-inch wrench, unscrew and take off 90° lubrication fitting (2)

END OF TASK

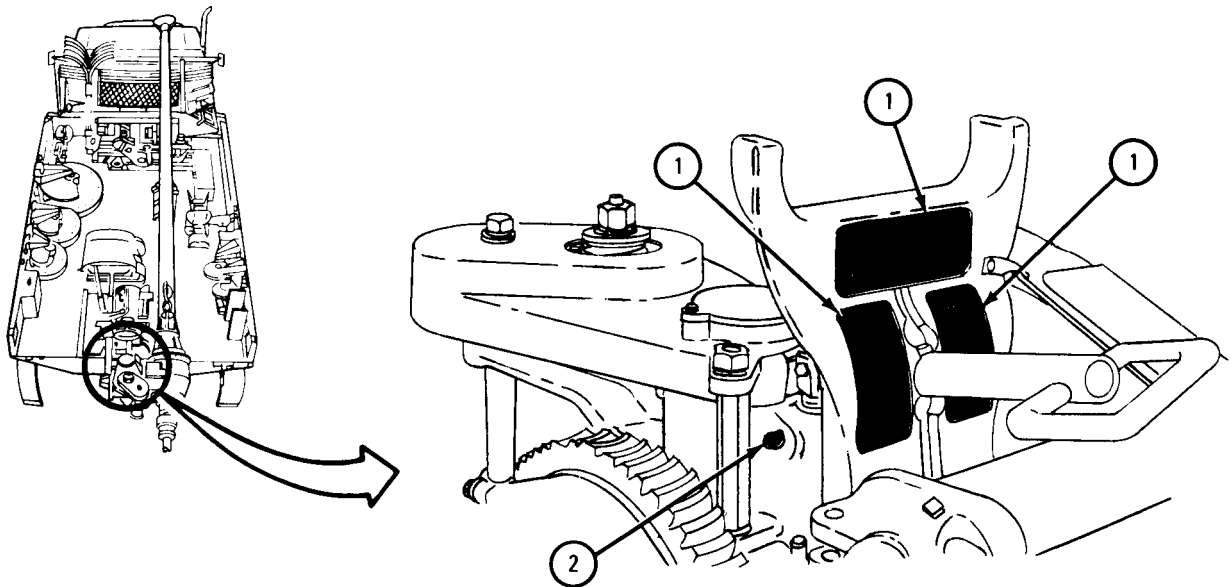

TA 047492

**WARNING**

Dry cleaning solvent is flammable. Do not use near an open flame. Keep a fire extinguisher nearby when solvent is used. Use only in well-ventilated places. Failure to do this may result in injury to personnel and damage to equipment.

- b. Cleaning. Using solvent, clean all parts.
- c. Inspection and Repair. Check that parts are not bent, broken or damaged in any way. If parts are damaged, get new ones.
- d. Replacement.

**FRAME 1**

- 1. Put on three data plates (1) . Refer to Part 4, para 21-7.
- 2. Using 7/16-inch wrench, screw on and tighten 90° lubrication fitting (2).

END OF TASK

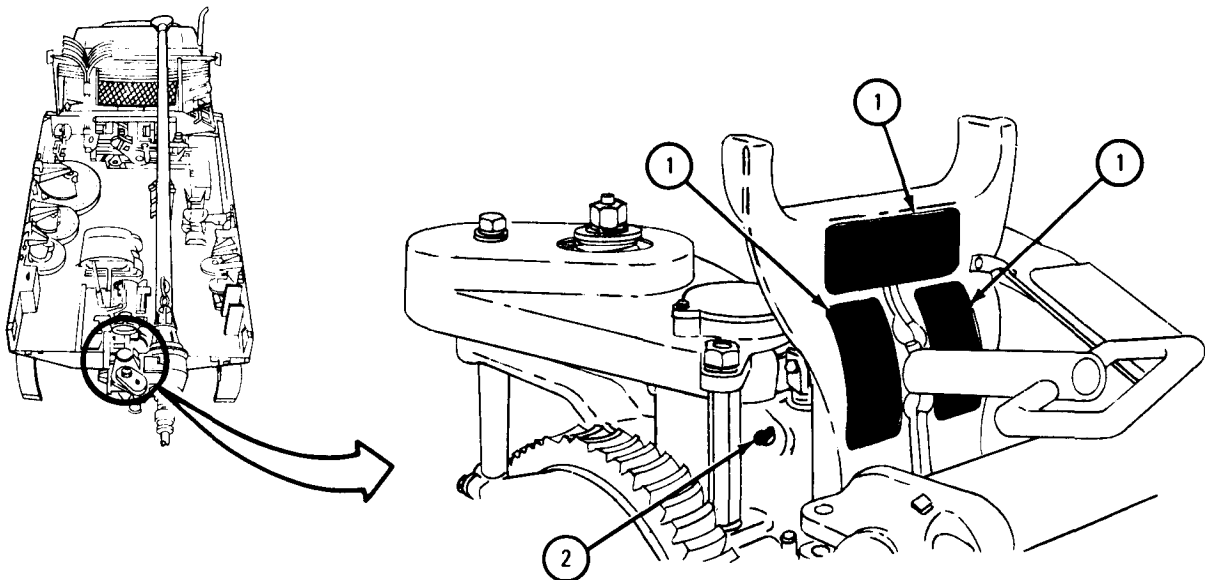

TA 047492

18-88. A-FRAME, GIN POLE, AND CLAMP ASSEMBLY REMOVAL, REPAIR , AND REPLACEMENT (TRUCK M756A2) .

NOTE

The tasks for the left and right gin poles and clamps are the same. This task is shown for the left side.

TOOLS : Drift pin punch  
½-inch wrench  
7/16-inch socket  
Pliers  
Medium ballpeen hammer

SUPPLIES : None

PERSONNEL: Two

EQUIPMENT CONDITION : Truck parked, engine off, handbrake set.

Preliminary Procedure. Put gin pole in stowed position. Refer to TM 9-2320-209-10.

b. Removal.

(1) Gin pole.

FRAME 1

1. Using pliers, pullout and throw away cotter pin (1). Loosen wing nut (2).
2. Using 7/16-inch socket, unscrew and take out grease fitting (3).
3. Using ½-inch wrench, unscrew and take out two screws (4) and lockwashers (5).

Soldier A 4. Hold and support gin pole (6).

Soldier B 5. Pull out pin (7) .

Soldiers 6. Lift up and put aside gin pole (6).  
A and B

GO TO FRAME 2

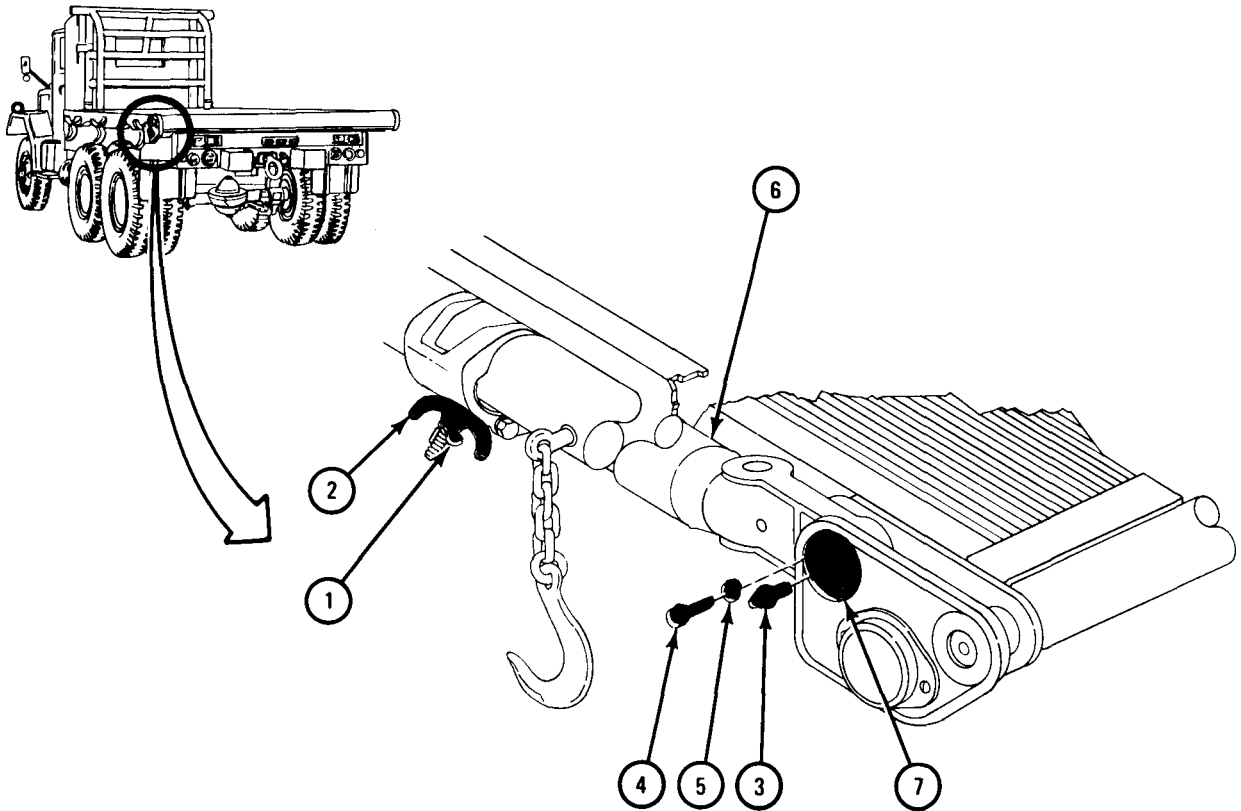

TA 083380

## FRAME 2

1. Using hammer and punch, drive out pin (1).
2. Using hammer and punch, drive out pin (2). Take off link (3).

END OF TASK

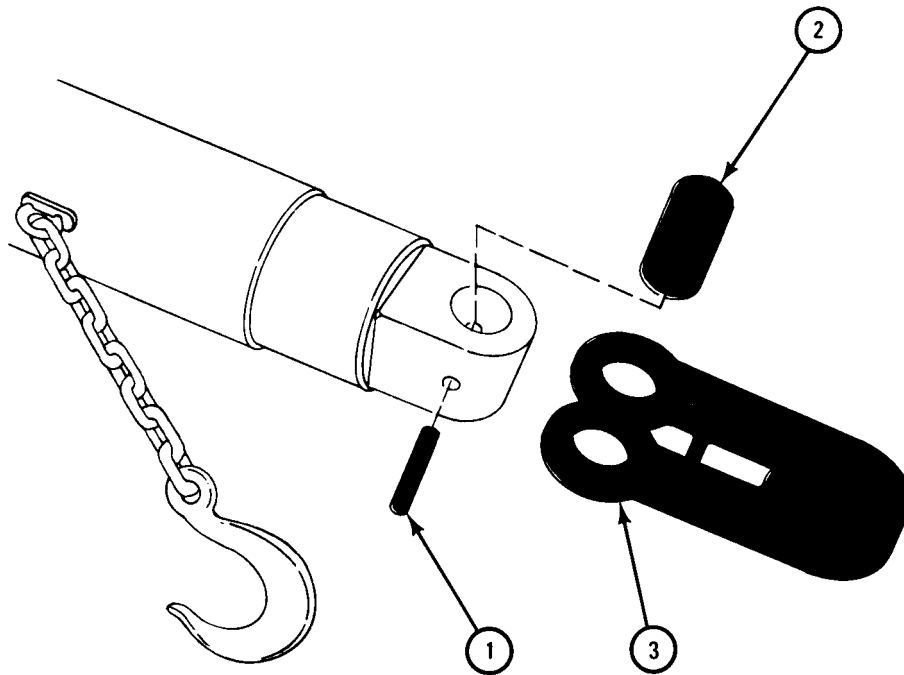

TA 083381

(2) Clamp.

FRAME 1

1. Unscrew and take off wing nut (1) with flat washer (2) and lockwasher (3).
2. Using pliers, pull out and throw away two cotter pins (4).
3. Holding clamp (5), and using hammer and punch, drive out pin (6) and take off clamp.
4. Holding eyebolt (7) and using hammer and punch, drive out pin (8) and take out eyebolt.

END OF TASK

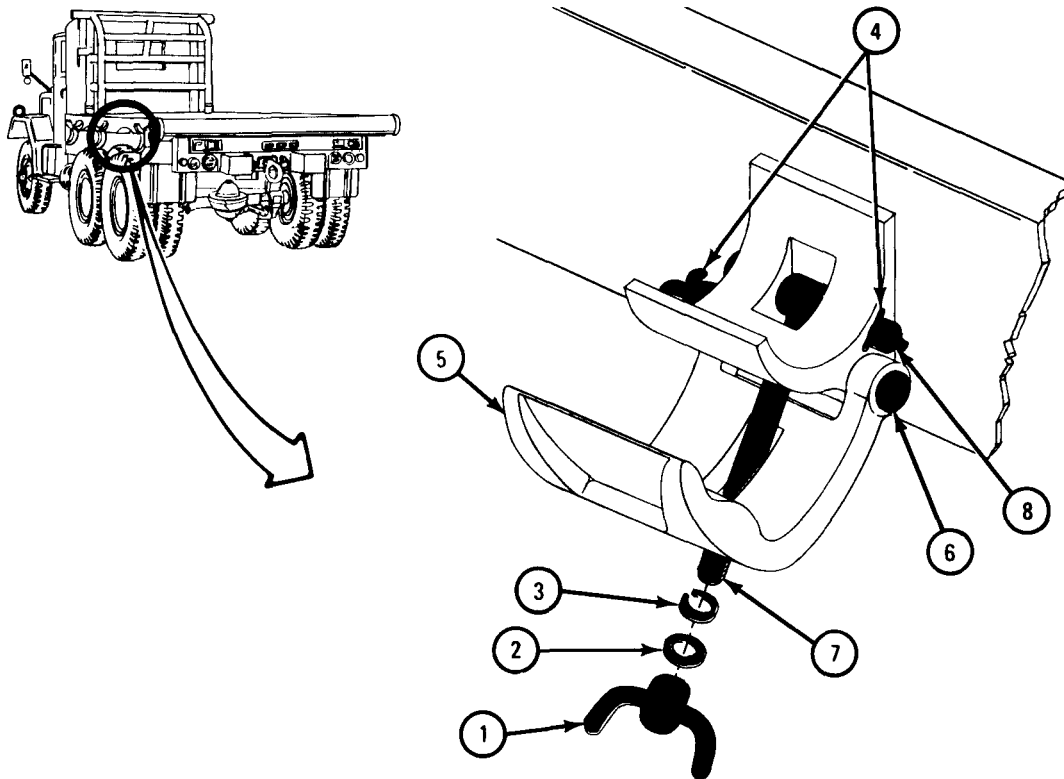

- c. Repair. Check all parts. If parts are damaged, get new ones.
- d. Replacement.
- (1) Clamp.

**FRAME 1**

1. Hold eyebolt (1) in place and put pin (2) through clamp bracket (3) and eyebolt (1).
2. Hold clamp (4) in place and put pin (5) through clamp bracket (3) and clamp (4). Use hammer to tap pins (2 and 5) in place.
3. Put two cotter pins (6) through holes in pins (2 and 5). Using pliers, bend open end of cotter pins.
4. Swing clamp (4) up so eyebolt (1) goes through hole in clamp.
5. Put lockwashers (7) and flat washer (8) on eyebolt (1) and screw on wing nut (9) two or three turns.

END OF TASK

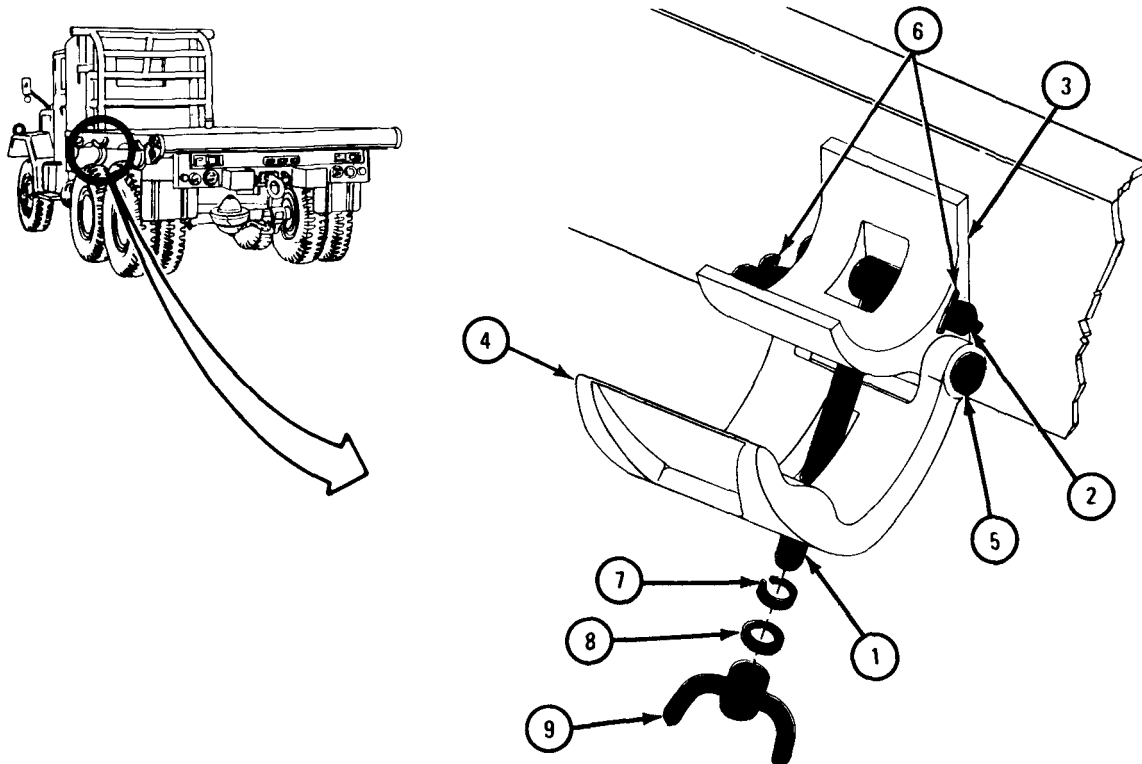

TA 083383

(2) Gin pole.

FRAME 1

1. Put link (1) on gin pole (2) and aline holes.
2. Using hammer, tap pin (3) through holes in link (1) and gin pole (2) so hole in pin alines with holes in gin pole.
3. Using hammer, tap pin (4) through holes in gin pole (2) and pin (3) until end of pin is flush with gin pole.

Go TO FRAME 2

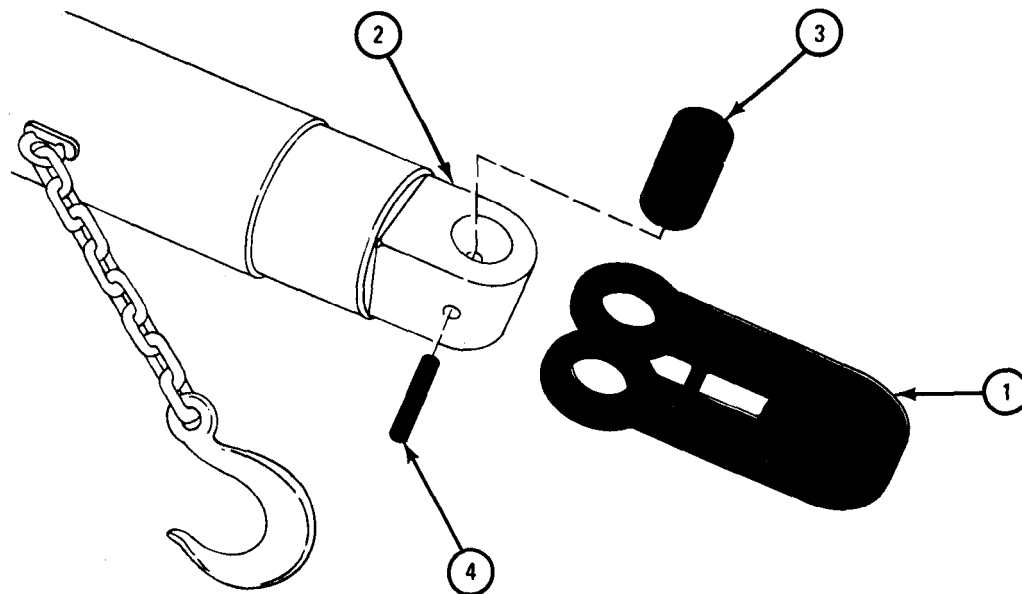

TA 083384



## FRAME 2

- Soldiers A and B 1. Lift up gin pole (1) and place it on clamp bracket (2) as shown,
- Soldier A 2. Hold and support gin pole (1).
- Soldier B 3. Put pin (3) into hole in bracket (4).
4. Using  $\frac{1}{2}$ -inch wrench, screw in and tighten two screws (5) with lockwashers (6).
5. Using  $\frac{7}{16}$ -inch socket, screw in and tighten grease fitting (7).
6. Tighten wing nut (8). Put cotter pin (9) through hole in eyebolt (10).
7. Using pliers, open ends of cotter pin (9).

## NOTE

Follow-on Maintenance Action Required:

Lubricate grease fitting. Refer to LO 9-2320-209-12/1.

END OF TASK

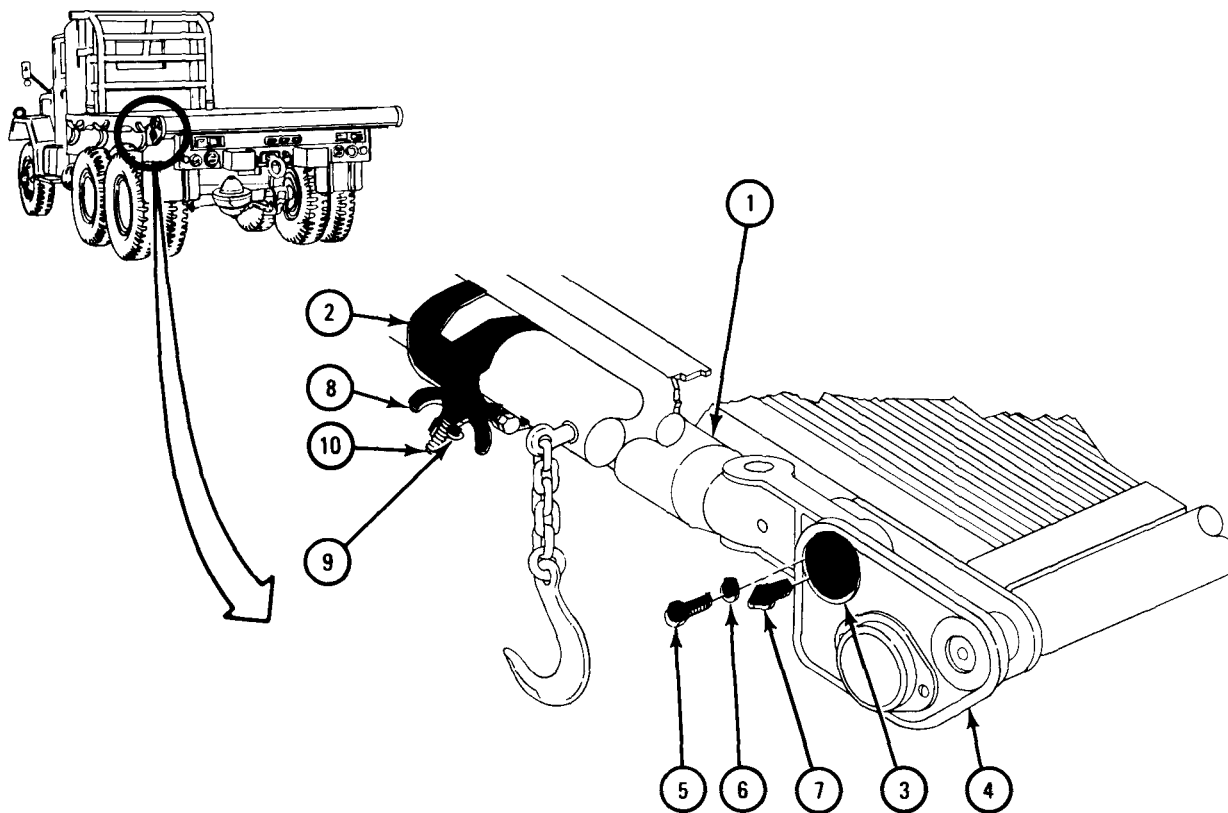

TA 083385

18-89. A-FRAME SHEAVE DISASSEMBLY AND ASSEMBLY (TRUCK M756A2) .

NOTE

This task is the same for the upper and lower sheave assemblies. This task is shown for the lower sheave assembly.

TOOLS : 1 7/8-inch wrench (2)  
7/16-inch wrench  
Pliers

SUPPLIES : None

PERSONNEL: One

EQUIPMENT CONDITION: Truck parked, engine off, handbrake set.

a. Preliminary Procedure. Remove sheave assembly from truck. Refer to TM 9-2320-209-10.

b. Disassembly.

## FRAME 1

1. Using 7/8-inch wrench, unscrew and take out lubrication fitting (1).
2. Using 1 7/8-inch wrenches, unscrew and take off two nuts (2).
3. Turn hand nut (3) to the left and takeoff side plate (4).
4. Takeout sheave (5), bushing (6), and sheave pin (7).

GO TO FRAME 2

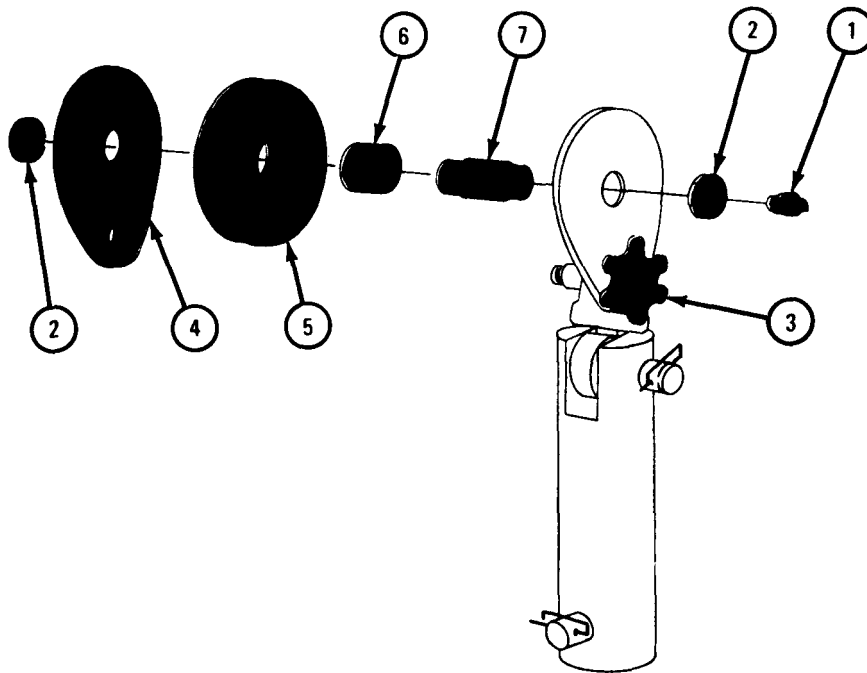

TA 083386

FRAME 2

1. Using pliers, pull out and throw away four cotter pins (1).
2. Pull out pin (2) and take off sheave mount assembly (3).
3. Pull out pin (4).

END OF TASK

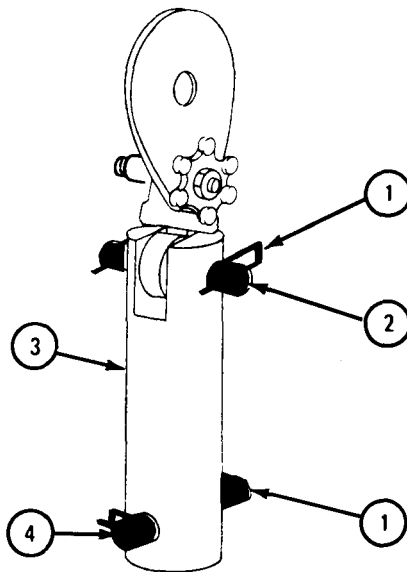

TA 083387

c. Assembly.**FRAME 1**

1. Push pin (1) through upper hole in sheave mount assembly (2) and hole in swivel block assembly (3).
2. Push two cotter pins (4) through holes in pin (1).
3. Push pin (5) through lower hole in sheave mount assembly (2).
4. Push two cotter pins (6) through holes in pin (5).
5. Using pliers, bend open ends of two cotter pins (4) and two cotter pins (6).

GO TO FRAME 2

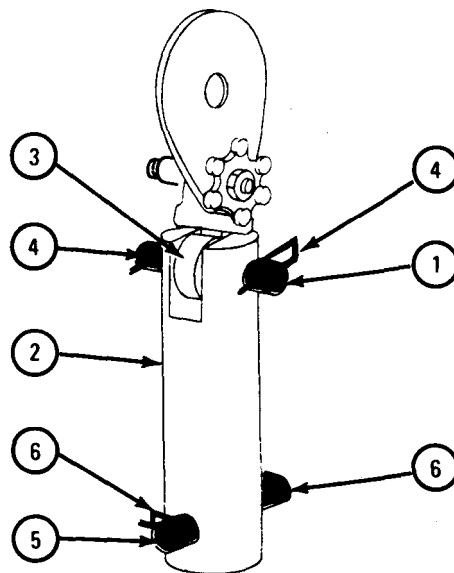

TA 083388

**FRAME 2**

1. Put side plate (1), sheave (2), and bushing (3) on sheave pin (4).
2. Put sheave pin (4) through hole in side plate (5).
3. Turn hand nut (6) to the right to screw retaining pin (7) into side plate (1).
4. Using 1 7/8-inch wrenches, screw on and tighten two nuts (8) .
5. Using 7/16-inch wrench, screw in and tighten lubrication fitting (9).

**NOTE**

Follow-on Maintenance Action Required:

Replace sheave assembly on truck. Refer to TM 9-2320-209-10.

END OF TASK

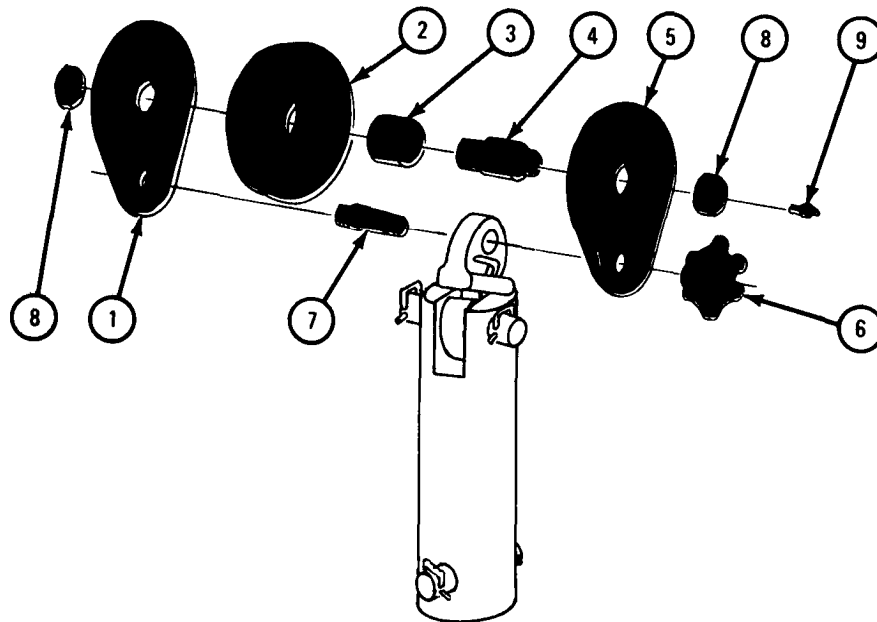

TA 083389

## 18-90. TOOLBOX REMOVAL AND REPLACEMENT (TRUCK M756A2).

TOOLS : 9/16-inch wrench (2)  
 3/4-inch wrench (2)  
 1/2-inch wrench (2)  
 Wood block, 2x 4x 6 inches (10)  
 Hydraulic jack, 12-ton capacity

SUPPLIES: None

PERSONNEL: Two

EQUIPMENT CONDITION: Truck parked, engine off, handbrake set.

a. Removal.

FRAME 1

1. Working on right side of truck, unlatch and open tool box door (1).
2. Using 1/2-inch wrenches, unscrew and take out two screws (2) and nuts (3).
3. Using 1/2-inch wrenches, unscrew and take out two screws (4) and nuts with washers (5).
4. Take off step plate (6).

GO TO FRAME 2

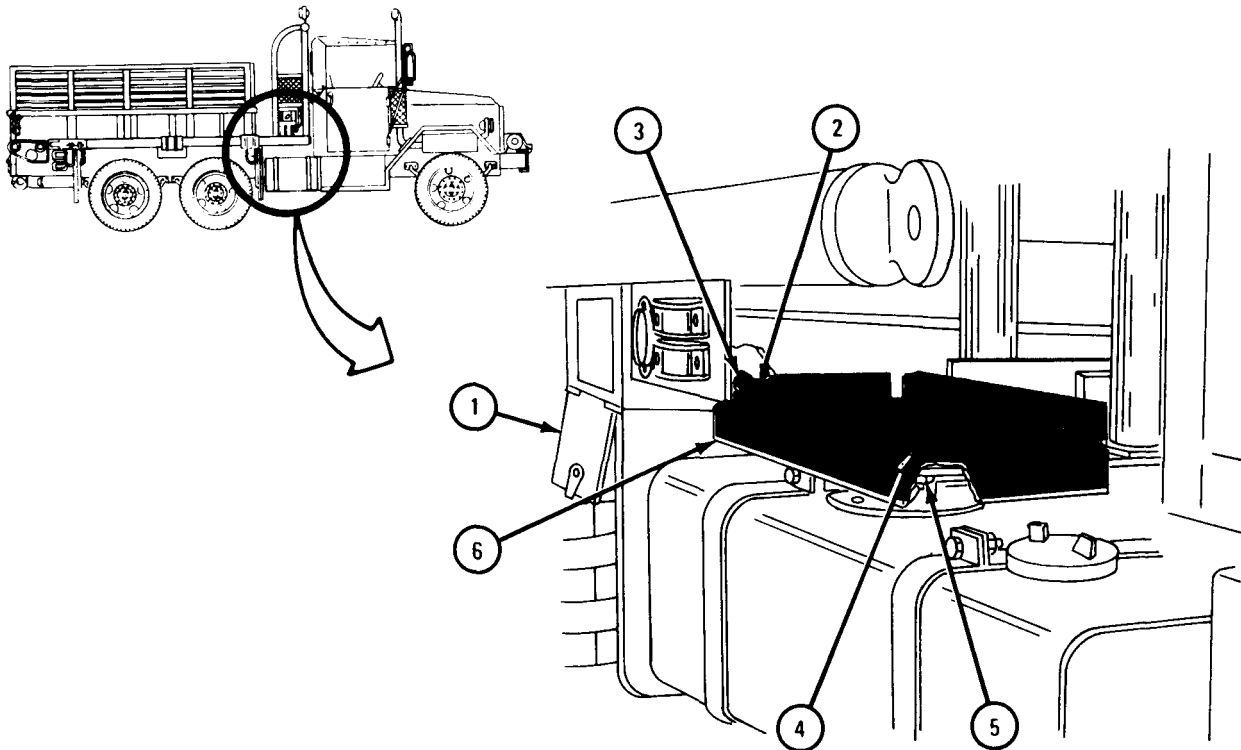

TA 083311

**FRAME 2**

1. Using 9/16-inch wrenches, unscrew and take out two screws (1) and nuts (2).
2. Take off hinge (3) and door (4).
3. Using 9/16-inch wrenches, unscrew and take off two screws (5), and nuts (6) with hinge (7).

GO TO FRAME 3

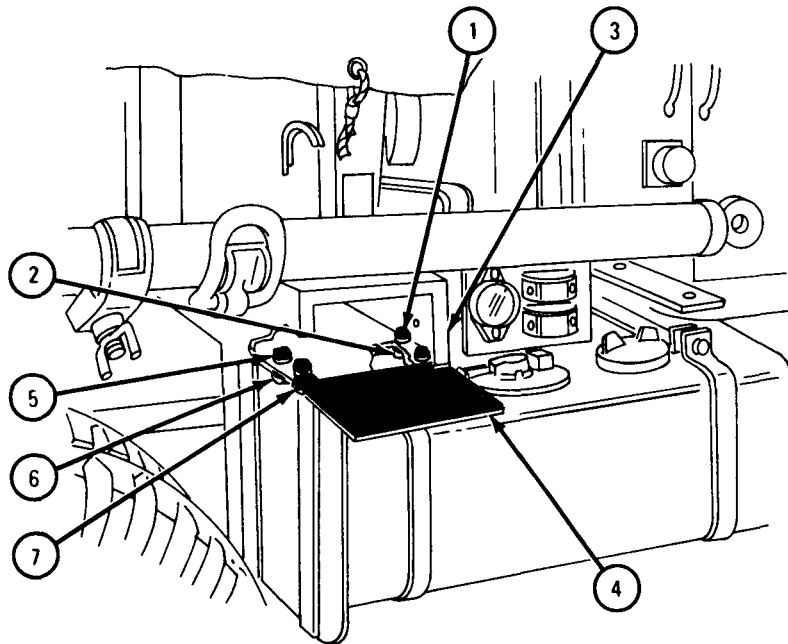

TA 083312



**FRAME 3**

1. Using 9/16-inch wrenches, unscrew and take off three screws (1), spacers (2), and nuts (3). Let splash guard (4) hang in place.
2. Using 3/4-inch wrenches, unscrew and take out two screws (5) and nuts (6).
3. Using 3/4-inch wrenches, unscrew and take out screw (7) and nut (8).

GO TO FRAME 4

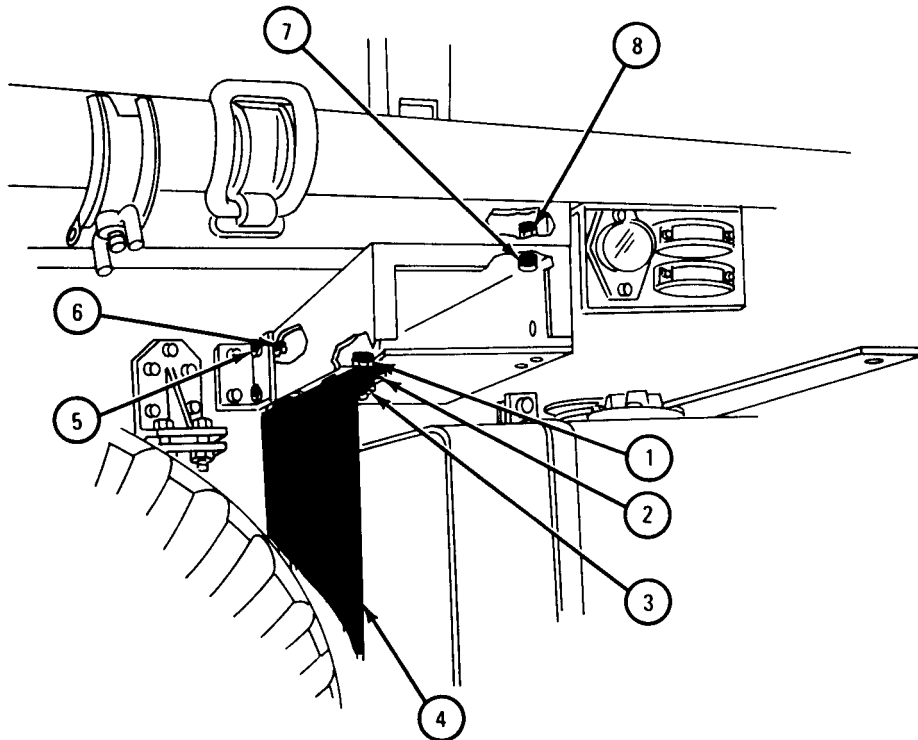

TA 083313

FRAME 4

1. Using 1 1/8-inch wrenches, loosen three screws (1) and nuts (2).

GO TO FRAME 5

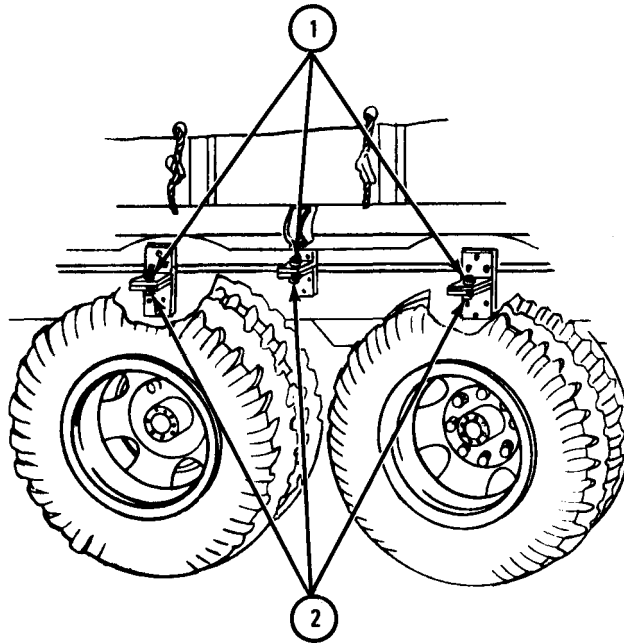

TA 083314

**FRAME 5**

1. Working on left side of truck, unlatch and open door (1) as shown.
2. Using  $\frac{3}{4}$ -inch wrenches, unscrew and take out two screws (2) and nuts (3).
3. Using  $\frac{3}{4}$ -inch wrenches, unscrew and take out screw (4) and nut (5).

GO TO FRAME 6

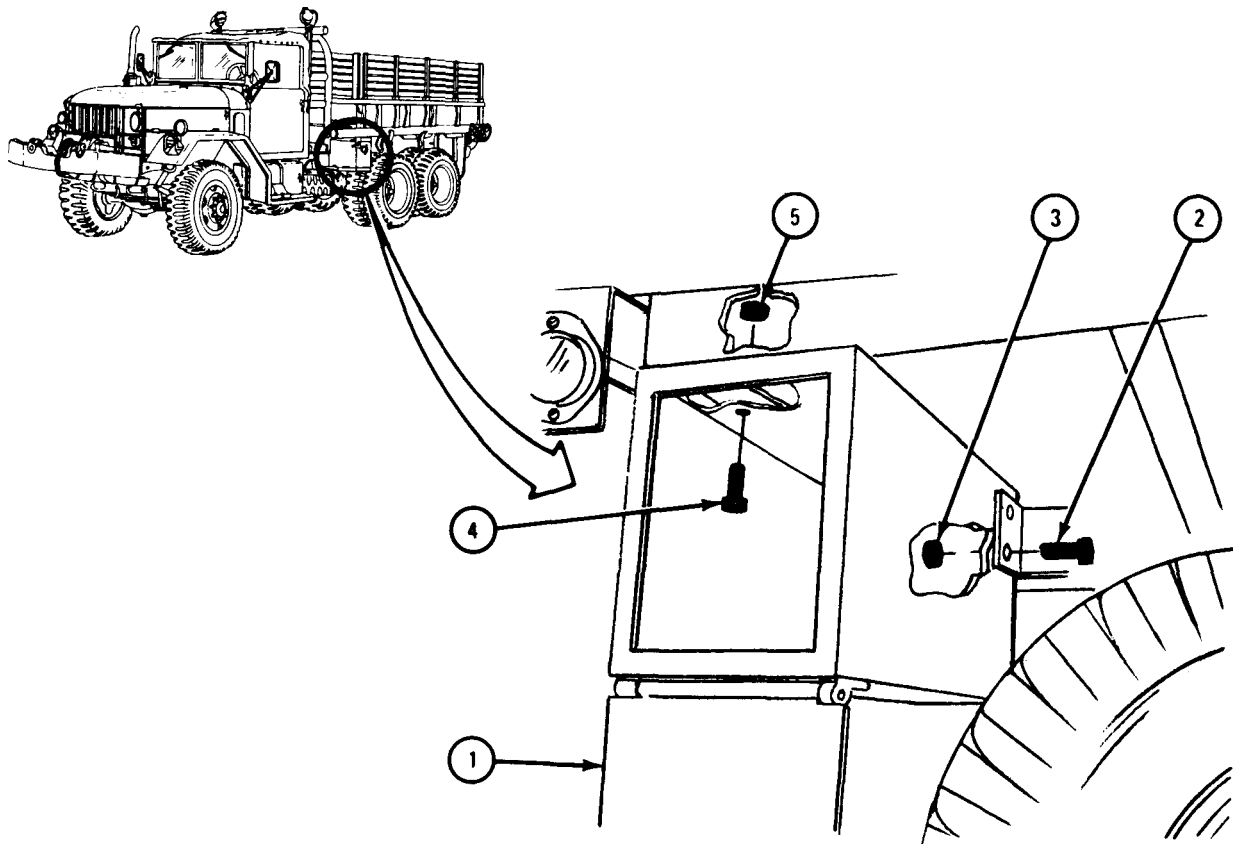

TA 083315

FRAME 6

1. Using 1 1/8-inch wrenches, loosen four screws (1) and nuts (2).  
GO TO FRAME 7

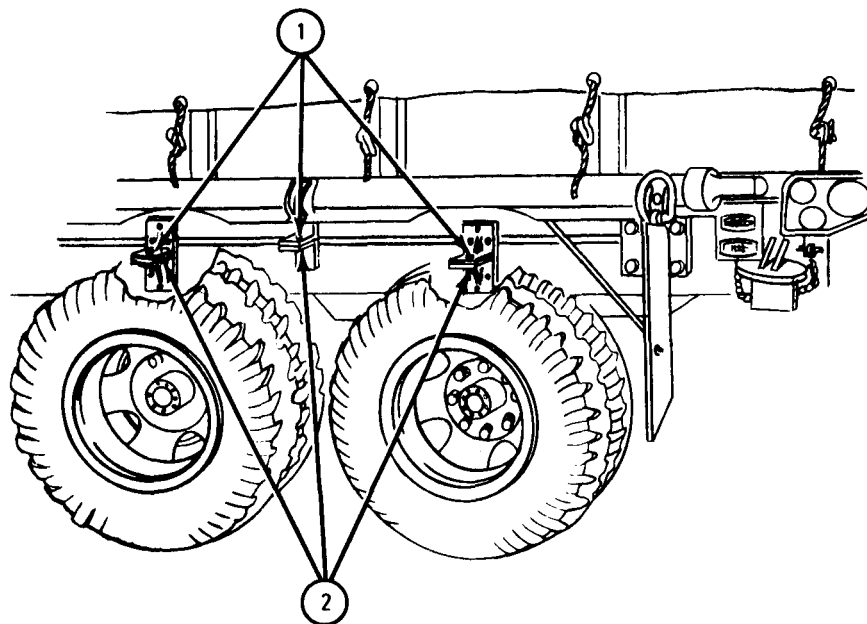

TA 083316

## FRAME 7

1. Working under left side of truck, stack wood blocks (1) in front of forward-rear axle (2) inside of left frame member (3) as shown.
2. Put hydraulic jack (4) in place as shown. Using jack, raise truck bed (5) to take pressure off tool box (6).

GO TO FRAME 8

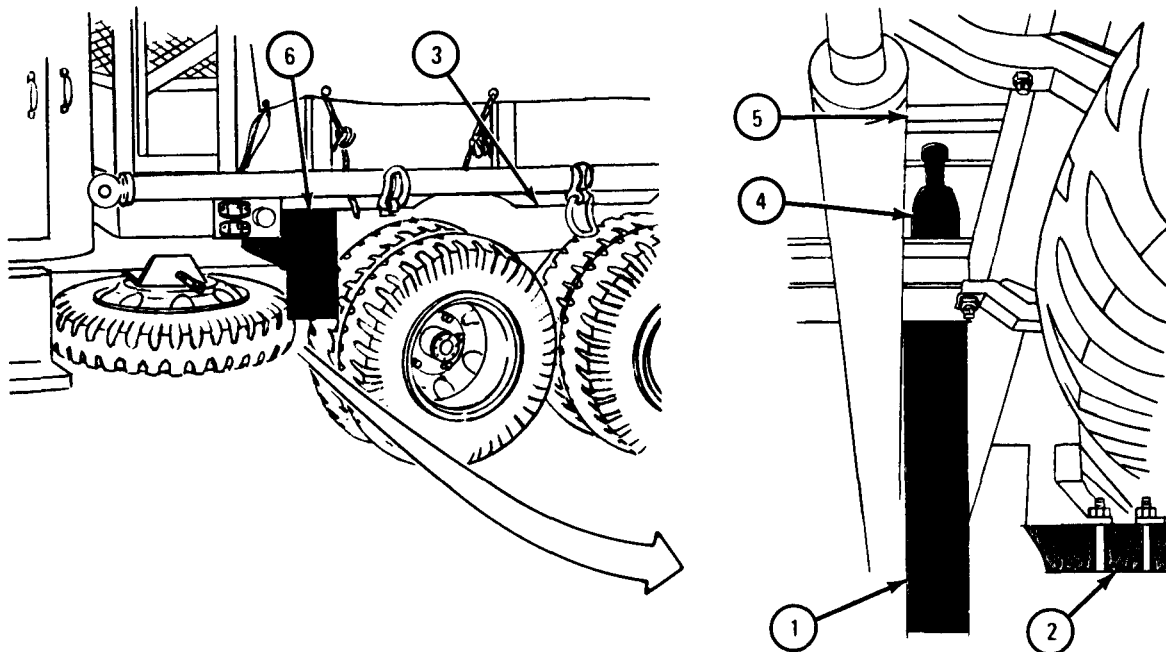

TA 083317

FRAME 8

Soldier A 1. Close and latch door (1).

Soldiers 2. Pullout and takeoff toolbox (2).  
A and B

END OF TASK

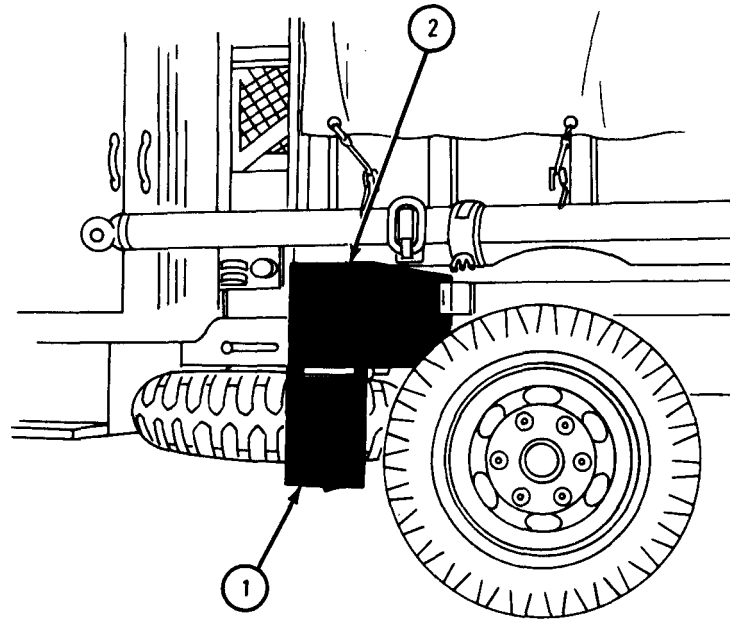

TA 083318

b . Replacement.**FRAME 1**

- Soldiers 1. Working on left side of truck, slide tool box (1) partway in A and B place over left frame number (2).
- Soldier A 2. Working under truck, guide tool box (1), as soldier B pushes tool box in place.
- Soldier B 3. Unlatch and open door (3) as shown.
- GO TO FRAME 2

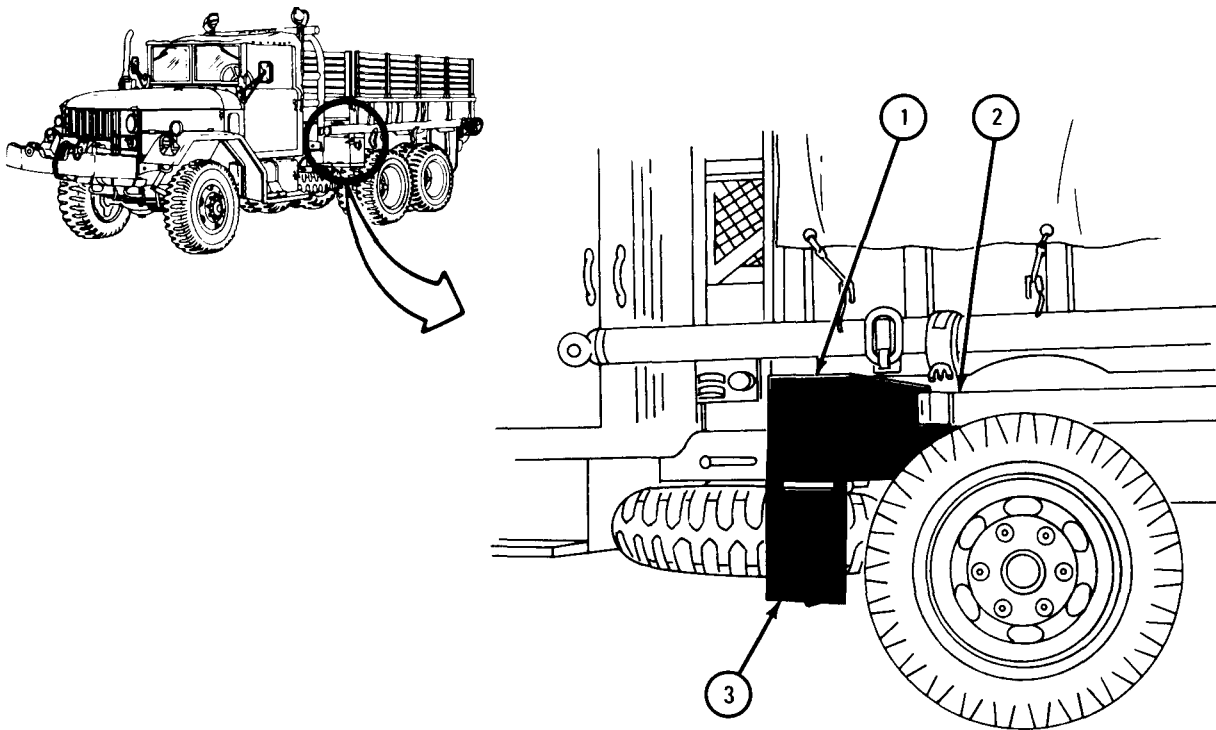

TA 083319

FRAME 2

- Soldier A 1. Hold tool box (1) up against truck bed (2).
- Soldier B 2. Put screw (3) up through hole in tool box (1) and truck bed crossmember (4) and hold screw in place. Screw on nut (5).
3. Put two screws (6) through holes in bracket (7) and tool box (1). Using  $\frac{3}{4}$ -inch wrenches, screw on and tighten two nuts (8).
4. Using  $\frac{3}{4}$ -inch wrenches, tighten screw (3) and nut (5).
- Soldier A 5. Let go of tool box (1). Close and latch door (9).
- GO TO FRAME 3

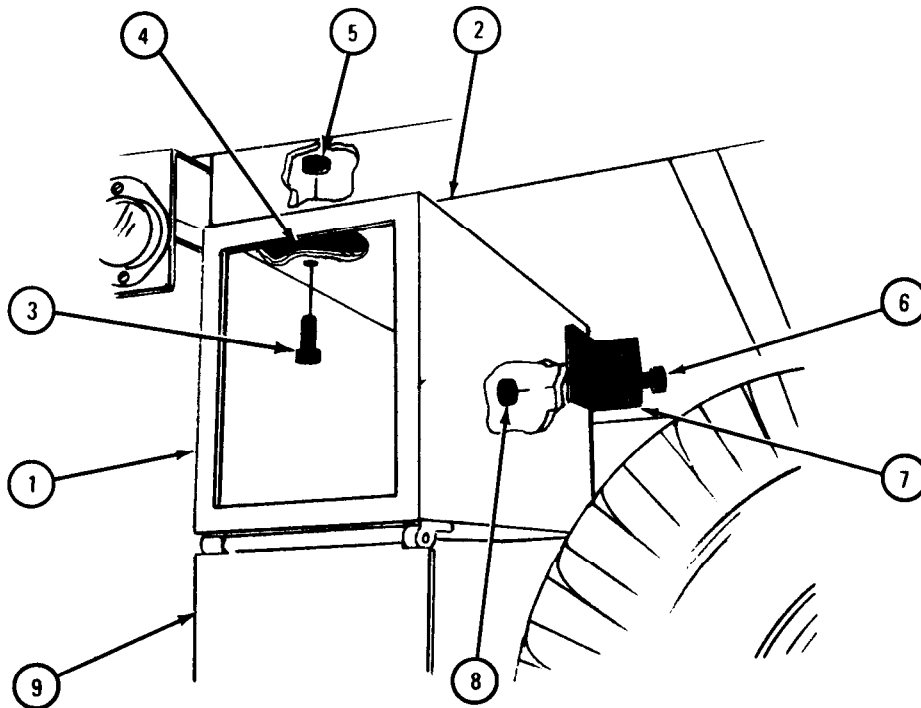

TA 083320



## FRAME 3

- Soldier A 1. Working on right side of truck, hold tool box (1) up against truck bed (2).
- Soldier B 2. Hold screw (3) up through hole in tool box (1) and truck bed cross-member (4). Screw on nut (5).
3. Put two screws (6) through holes in bracket (7) and tool box (1). Using  $\frac{3}{4}$ -inch wrenches, screw on and tighten two nuts (8).
4. Using  $\frac{3}{4}$ -inch wrenches, tighten screw (3) and nut (5).
- Soldier A 5. Let go of tool box (1).

GO TO FRAME 4

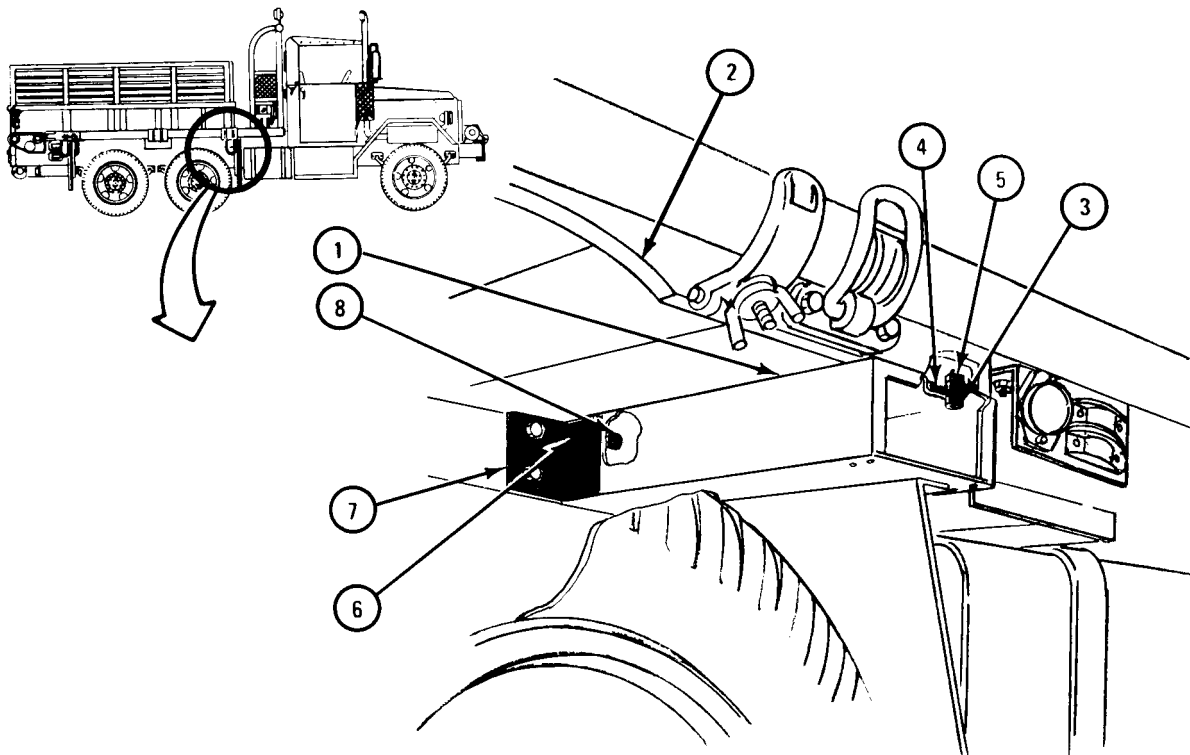

TA 083321

FRAME 4

1. Working under truck and using hydraulic jack (1), lower truck bed (2). Take jack out.
2. Take out wood blocks (3).

GO TO FRAME 5

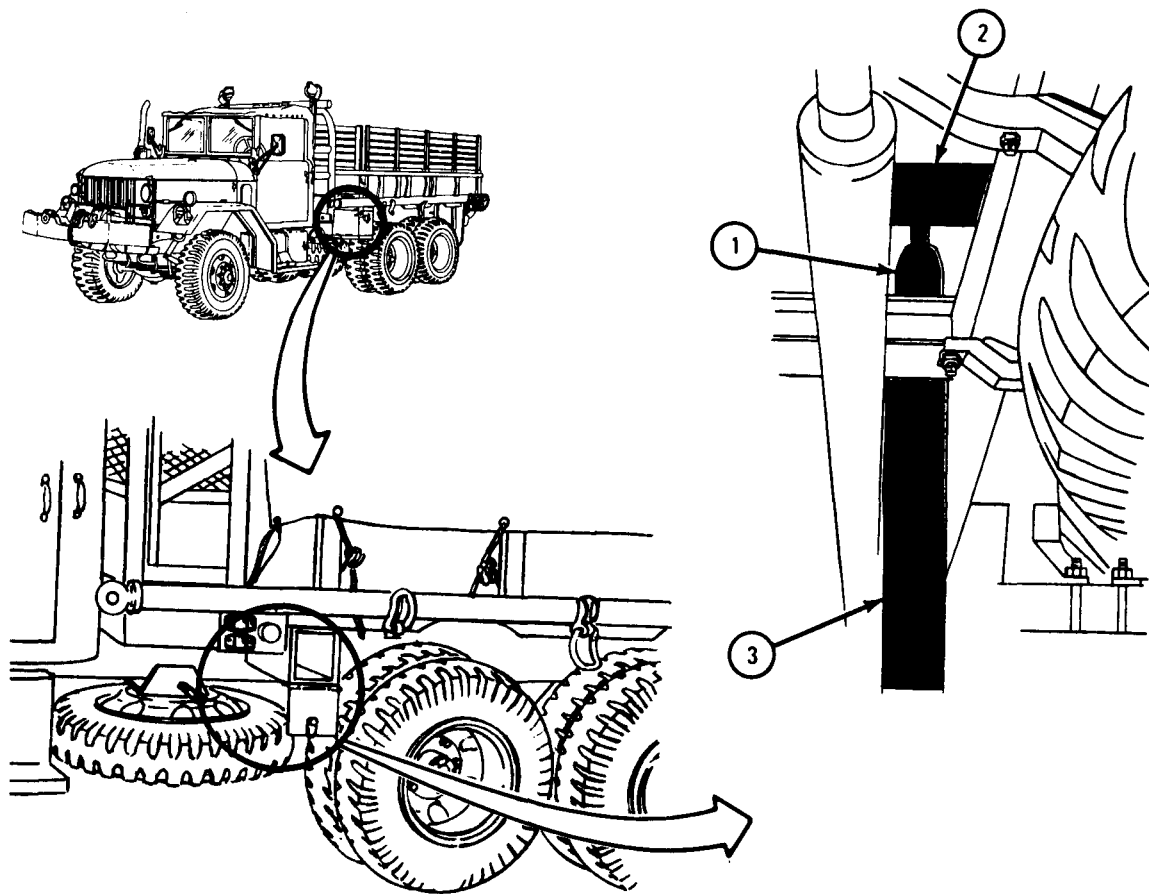

TA 083322

## FRAME 5

1. Using 1 1/8-inch wrenches, tighten four screws (1) and nuts (2).

GO TO FRAME 6

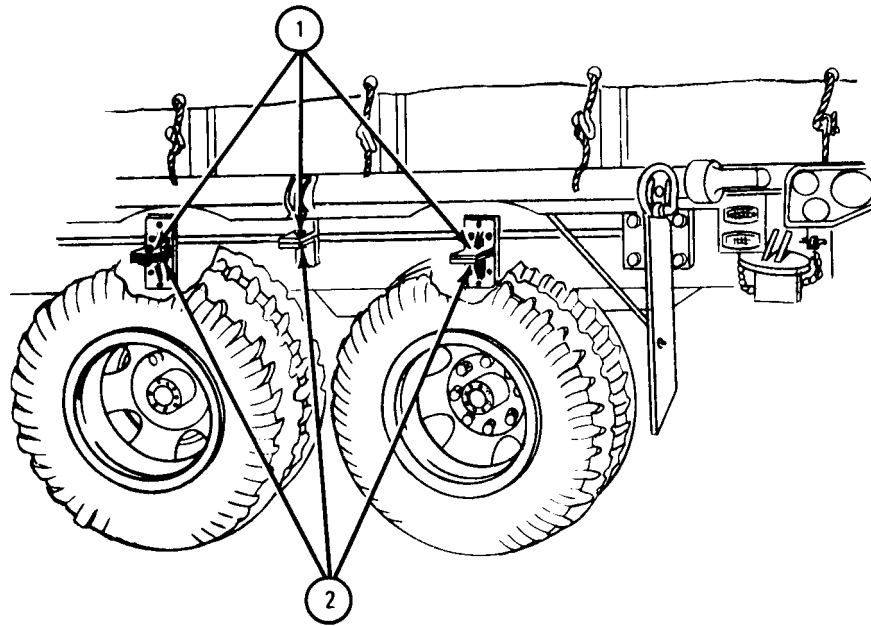

TA 083316

FRAME 1

1. Working on right side of truck and using 1 1/8-inch wrenches, tighten four screws (1) and nuts (2) .

GO TO FRAME 7

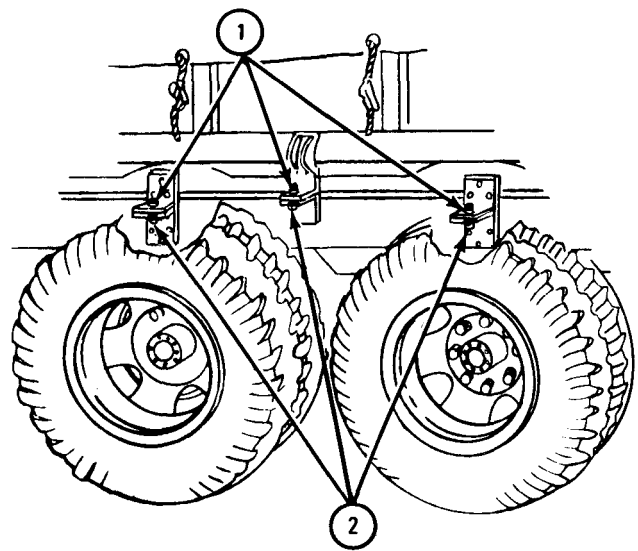
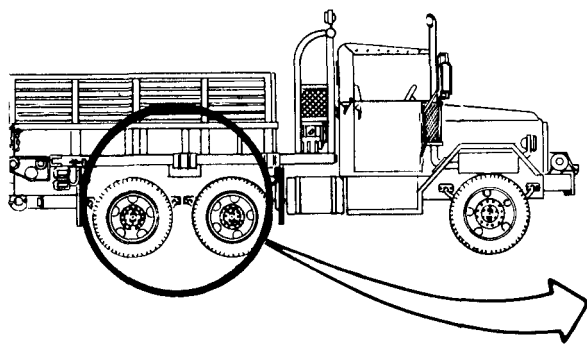

TA 083323

## FRAME 7

- Soldier A 1. Put three screws (1) through holes in toolbox (2).
2. Put and hold three spacers (3) on three screws (1).
- Soldier B 3. Put and hold splash guard (4) in place, with three screws (1) through holes in splash guard.
- Soldier A 4. Using 9/16-inch wrenches, screw on and tighten three nuts (5).
- GO TO FRAME 8

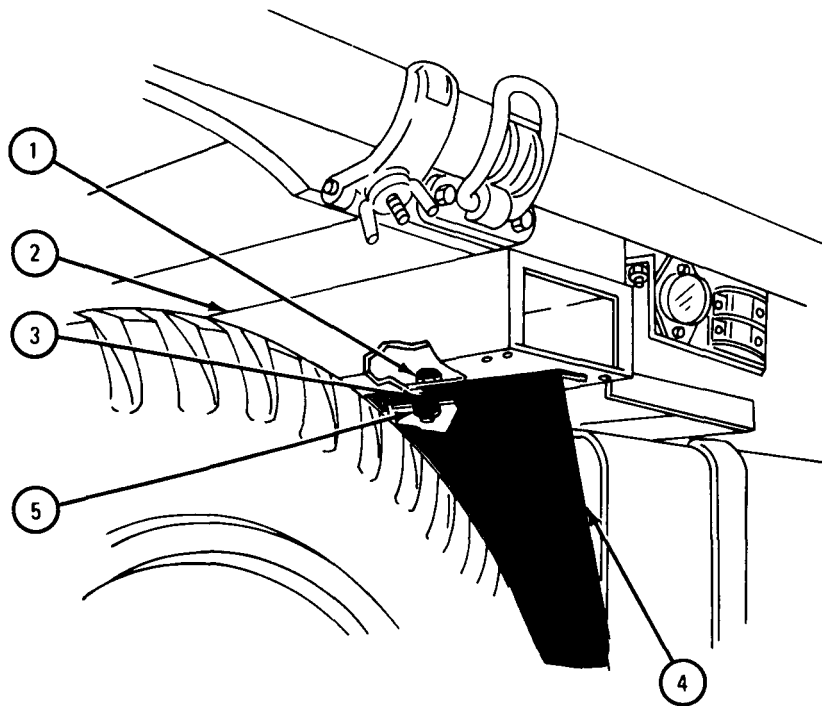

TA 083324

FRAME 8

1. Put two screws (1) down through holes in bottom of tool box (2).
2. Put and hold hinge (3) in place on tool box (2), with two screws (1) through holes in hinge. Screw on two nuts (4).
3. Using 9/16-inch wrenches, tighten two screws (1) and nuts (4).
4. Put two screws (5) down through holes in right front of bottom of tool box (2).
5. Put left hinge post of door (6) into hinge (3) and hold hinge (7) on right hinge post of door.
6. Put and hold hinge (7) with door (6) in place on toolbox (2) with two screws (5) through holes in hinge. Screw on two nuts (8).
7. Using 9/16-inch wrenches, tighten two screws (5) and nuts (8).

GO TO FRAME 9

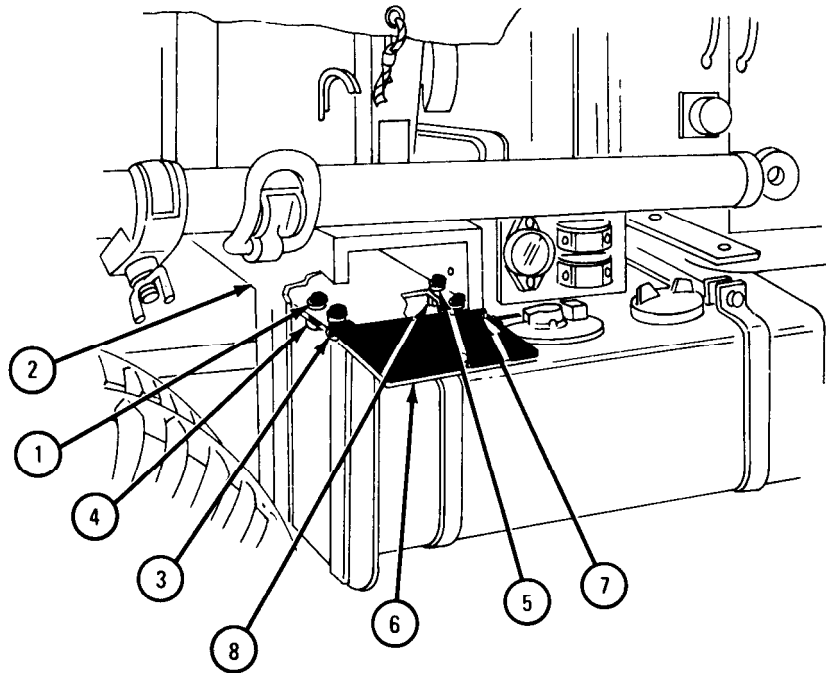

TA 083325

## FRAME 9

1. Put step plate (1) in place on truck as shown and put two screws (2) through holes in step plate and toolbox (3). Screw on two nuts (4).
2. Put two screws (5) down through holes in step plate (1) and bracket (6). Screw on two nuts (7).
3. Using  $\frac{1}{2}$ -inch wrenches, tighten two screws (2) and nuts (4) and two screws (5) and nuts (7).
4. Close and latch door (8).

END OF TASK

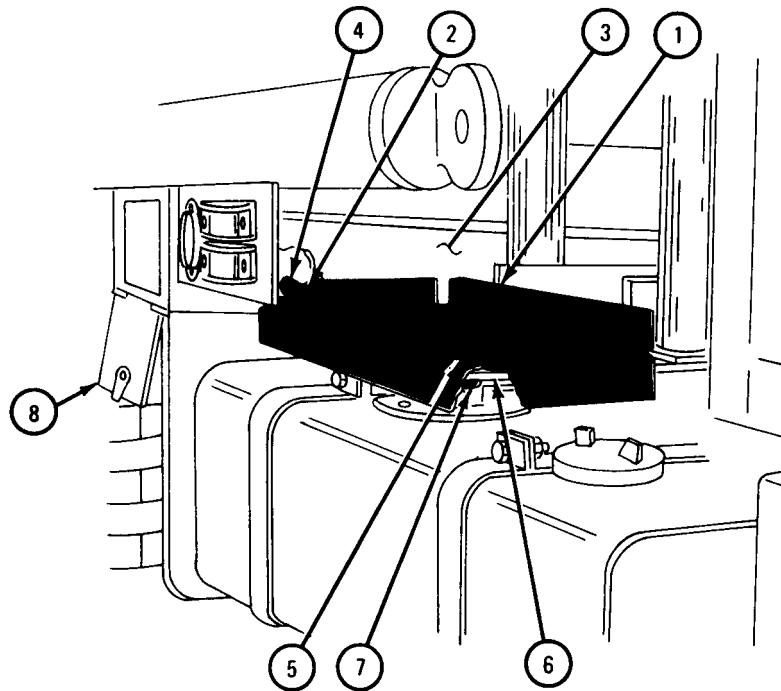

TA 083326

18-91. REAR SPLASH GUARDS REMOVAL AND REPLACEMENT (TRUCK M756A2).

NOTE

The task for the right and left splash guards is the same.  
The left splash guard is shown in this task.

TOOLS: 9/16-inch wrench (2)

SUPPLIES: None

PERSONNEL: One

EQUIPMENT CONDITION: Truck parked, engine off, handbrake set.

a. Removal.

**FRAME 1**

1. Using wrenches, unscrew and take out two screws (1) and nuts (2), Take off brace (3).
2. Using wrenches, unscrew and take off nuts (4) . Take off splash guard (5). Take out two screws (6).
3. Using wrenches, unscrew and take out three screws (7) and nuts (8). Take off angle iron (9).

END OF TASK

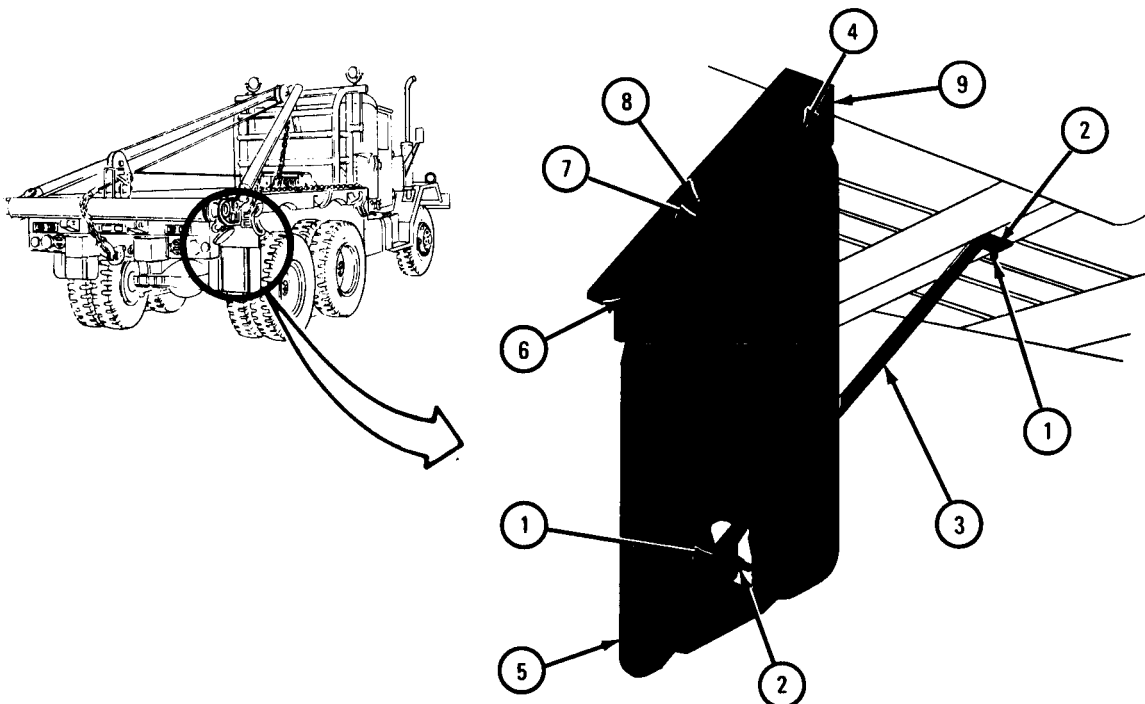

TA 083260



b. Replacement.**FRAME 1**

1. Put three screws (1) through holes in crossmember (2).
2. Hold angle iron (3) against bottom of crossmember (2) so three screws go through three holes in angle iron. Screw on three nuts (4).
3. Using wrenches, tighten three screws (1) and nuts (4).
4. Put two screws (5) through holes in splash guard (6) and angel iron (3). Screw on two nuts (7).
5. Using wrenches, tighten two screws (5) and nuts (7).

GO TO FRAME 2

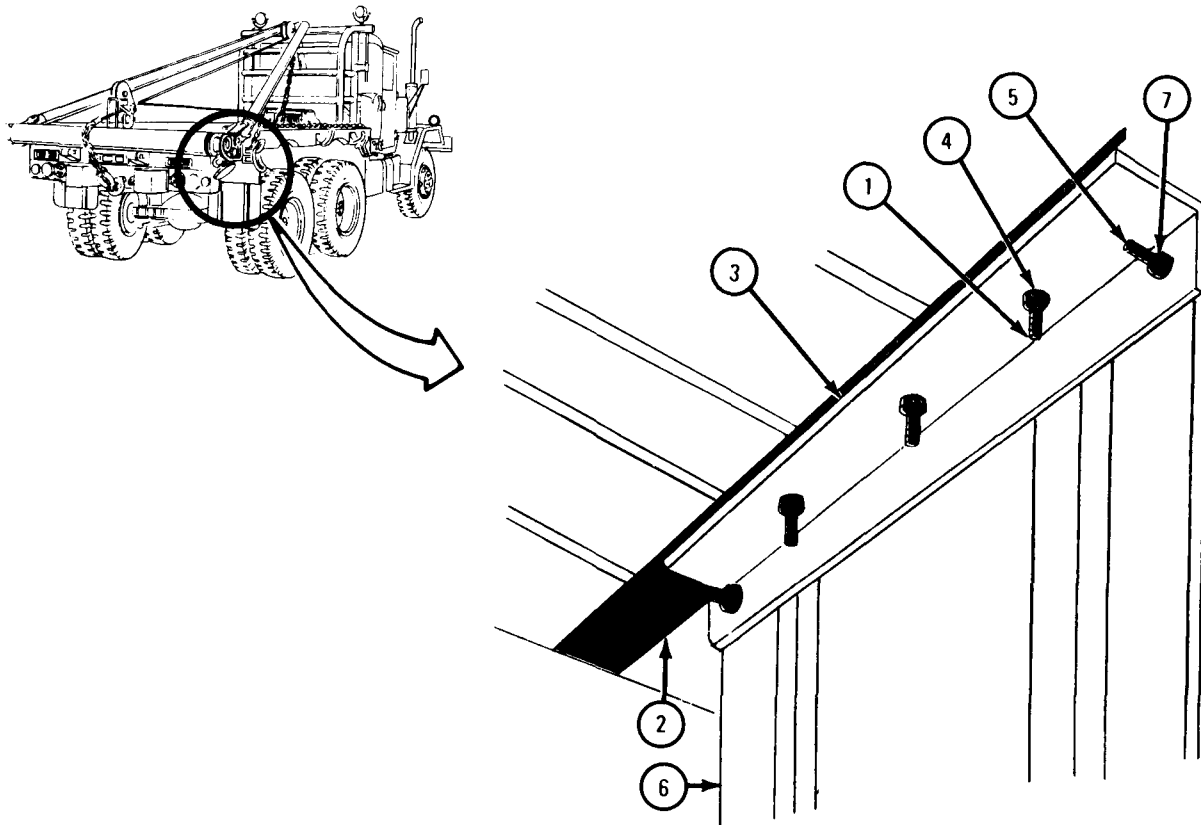

TA 083261

**FRAME 2**

1. Put screw (1) through hole in crossmember (2).
2. Hold brace (3) against bottom of crossmember (2) as shown so screw (1) goes through screw hole in brace. Screw on nut (4).
3. Put screw (5) through hole in splashguard (6) and brace (3). Screw on nut (7).
4. Using wrenches, tighten two screws (1 and 5) and nuts (4 and 7).

END OF TASK

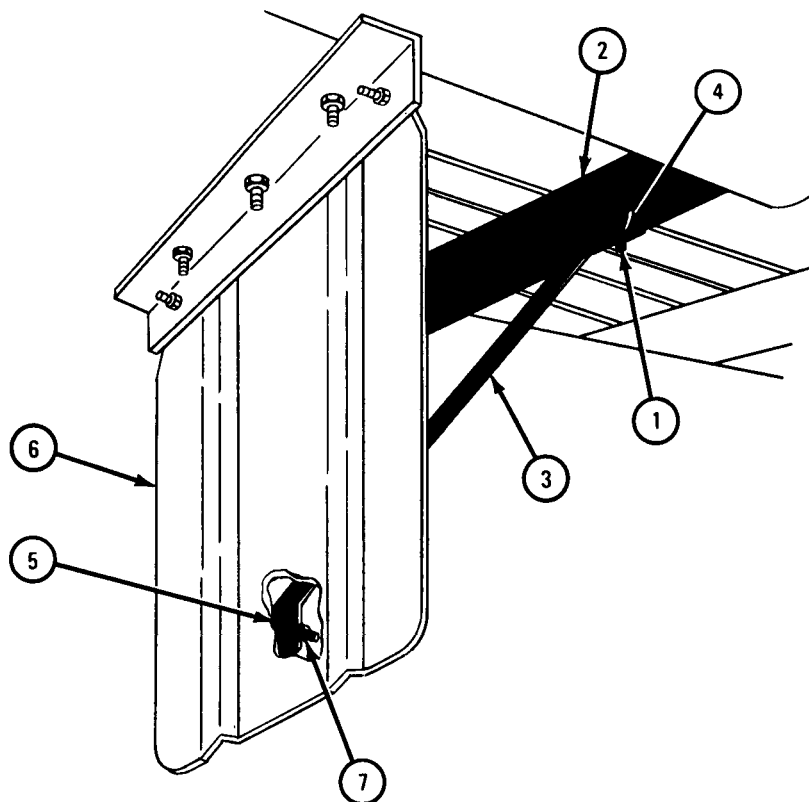

TA 083262

18-92. AUXILIARY ROLLER BRACKET ASSEMBLY REMOVAL, REPAIR, AND REPLACEMENT (TRUCK M756A2).

NOTE

This task is the same for left and right roller assemblies. This task is shown for the right roller assembly.

TOOLS : Pliers  
7/16-inch wrench  
3/4-inch open end wrench  
1 1/2-inch wrench (2)  
3/4-inch socket

SUPPLIES : None

PERSONNEL: Two

EQUIPMENT CONDITION: Truck parked, engine off, handbrakes set.

a. Removal.

FRAME 1

1. Using pliers, pull out and throw away cotter pin (1) .
2. Using 7/16-inch wrench, unscrew and take off grease fitting (2) .
3. Using 1 1/2-inch wrenches, hold roller shaft (3) and unscrew and take off nut (4) and washer (5) .
4. Take out roller shaft (3) and roller (6) .
5. Do steps 1 through 4 again to take out rear roller (7) .

GO TO FRAME 2

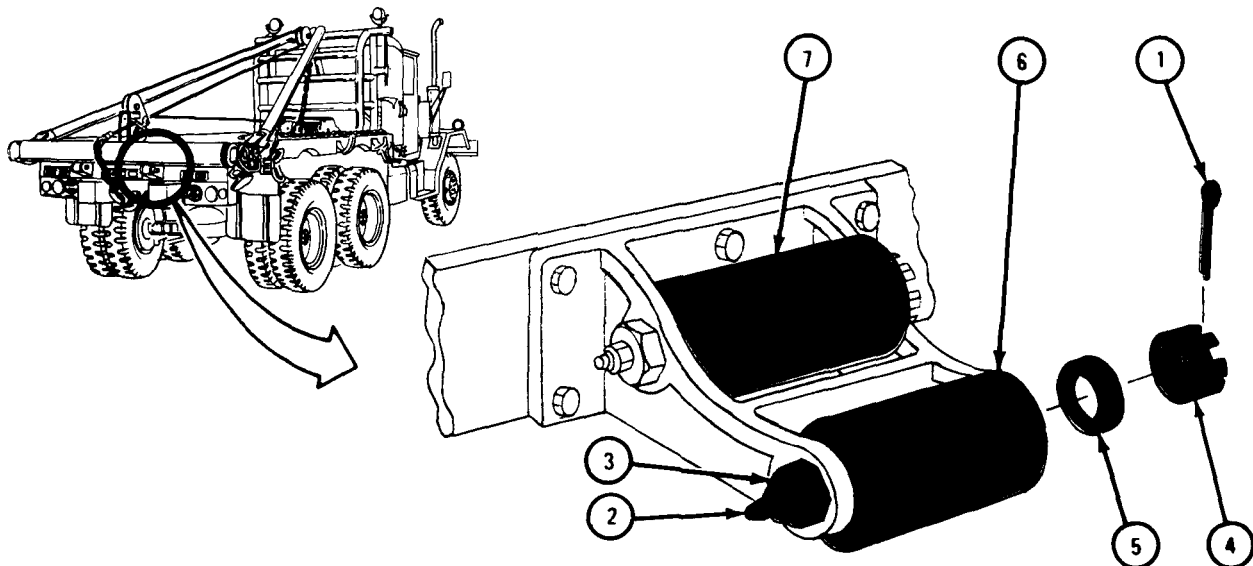

TA 083273

FRAME 2

- Soldier A 1. Using  $\frac{3}{4}$ -inch wrench, hold three top capscrews (1). Tell soldier B when ready.
- Soldier B 2. Working under truck and using  $\frac{3}{4}$ -inch socket wrench, unscrew and take off three top nuts (2). Tell soldier A when ready.
- Soldier A 3. Take off three capscrews (1). Using  $\frac{3}{4}$ -inch wrench, unscrew and take off three capscrews (3). Take off mounting bracket (4).
- END OF TASK

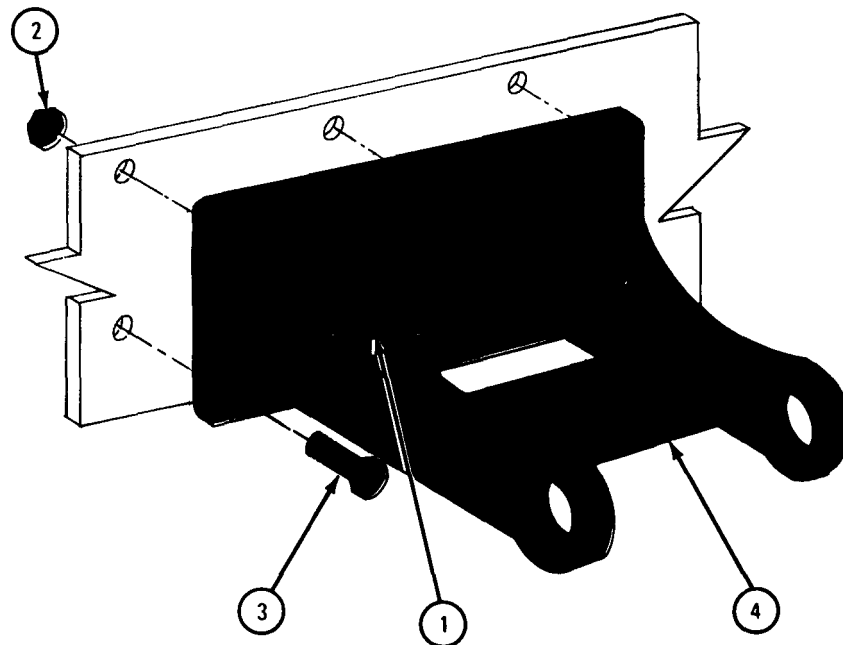

TA 083274

b. Repair. Check that all parts are not worn or damaged. If parts are damaged, get new ones.

c. Replacement.

FRAME 1

Soldier A 1. Hold bracket (1) in place and aline holes.

2. Put three cap screws (2) through holes in bracket (1). Using  $\frac{3}{4}$ -inch wrench, hold cap screws. Tell soldier B when ready.

Soldier B 3. Working under truck and using  $\frac{3}{4}$ -inch open end wrench, screw on and tighten three nuts (3).

Soldier A 4. Using  $\frac{3}{4}$ -inch wrench, screw in and tighten three capscrews (4).

GO TO FRAME 2

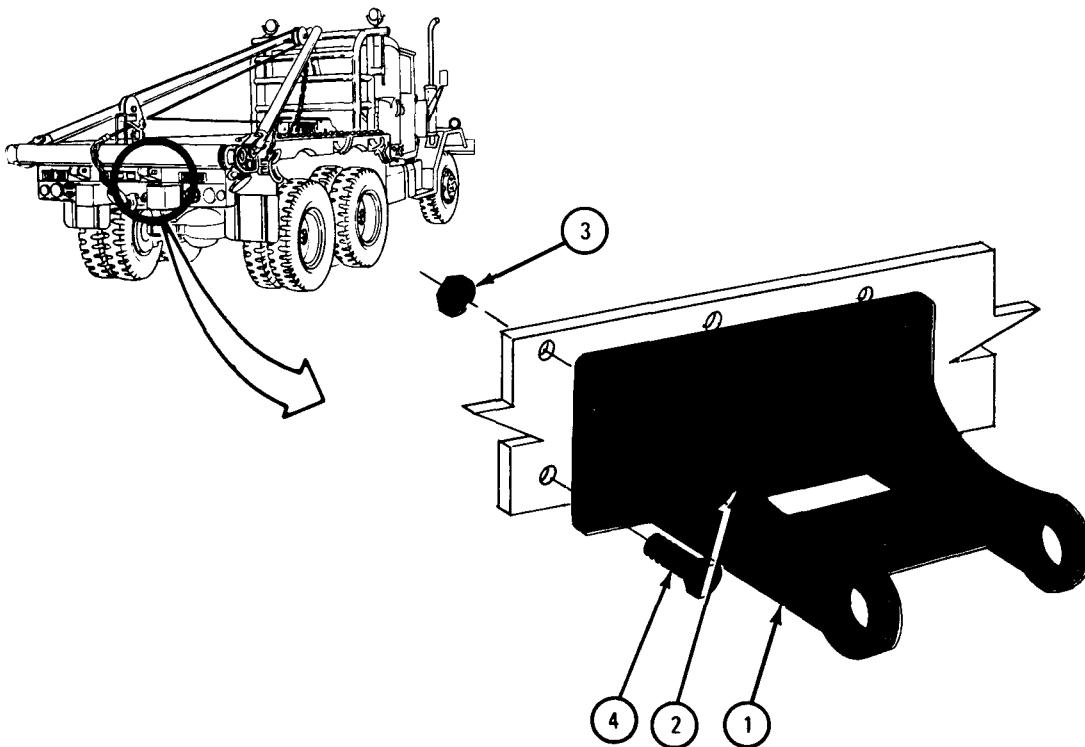

TA 083275

FRAME 2

1. Hold roller (1) in place, and put roller shaft (2) through holes in bracket (3) and roller. Put washer (4) on roller shaft.
2. Using 1 ½-inch wrenches, hold roller shaft (2) and screw on and tighten nut (5). Align a slot in nut with hole in roller shaft.
3. Put cotter pin (6) through slot in nut (5) and hole in roller shaft (2). Using pliers, bend open ends of cotter pin.
4. Using 7/16-inch wrench, screw in and tighten grease fitting (7).
5. Do steps 1 through 4 again for roller (8).

NOTE

Follow-on Maintenance Action Required:

Lubricate roller assemblies. Refer to LO 9-2320-209-12/1.

END OF TASK

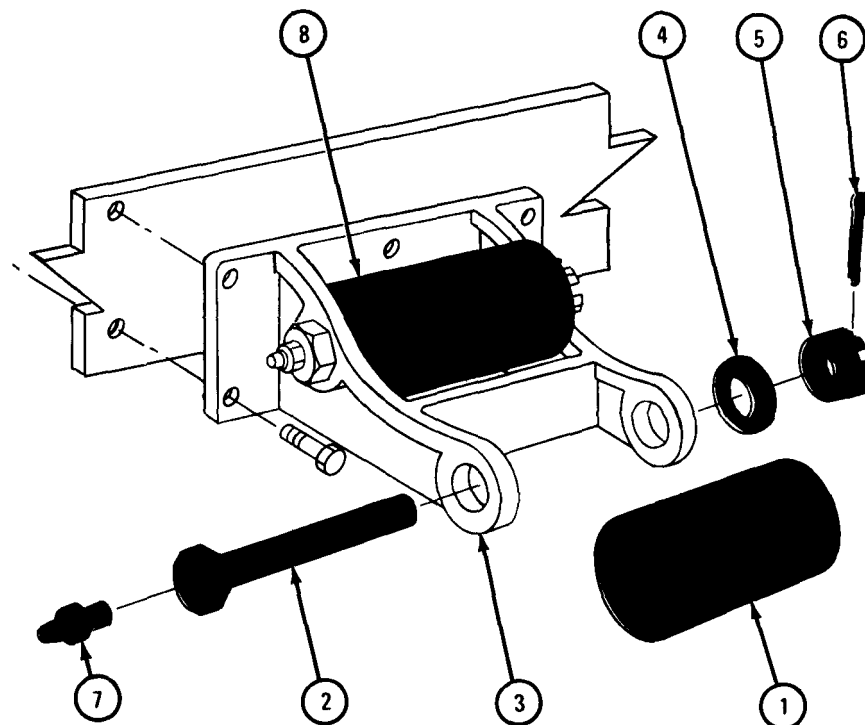

TA 083276

18-93. TAILBOARD ROLLER ASSEMBLY REMOVAL, REPAIR, AND REPLACEMENT  
(TRUCK M756A2) .

TOOLS :    ½-inch open end wrench  
          Flat-tip screwdriver  
          ½-inch rope, 15 feet  
          Hoist

SUPPLIES:   None

PERSONNEL:   Two

EQUIPMENT CONDITION: Truck parked, engine off, handbrake set.

a. Preliminary Procedures.

- (1) If truck has tailgate, take it off. Refer to para 18-16.
- (2) If truck has side racks, take them off. Refer to TM 9-2320-209-10.
- (3) If truck has drop sides, take them off. Refer to TM 9-2320-209-10.

b. Removal.

FRAME 1

- Soldier A
1. Hook up rope (1) to tailboard roller (2) and hoist (3) as shown.
  2. Hold tailboard roller (2) in place.
  3. Working on right side, and using wrench, unscrew and take off four screws (4) and lockwashers (5).
  4. Pull out roller pin (6) and take off shim (7).
  5. Do steps 2 and 3 again for left side of roller (2).
- Soldiers A and B
6. Using hoist (3), lift tailboard roller (2) up and away from truck.
- GO TO FRAME 2

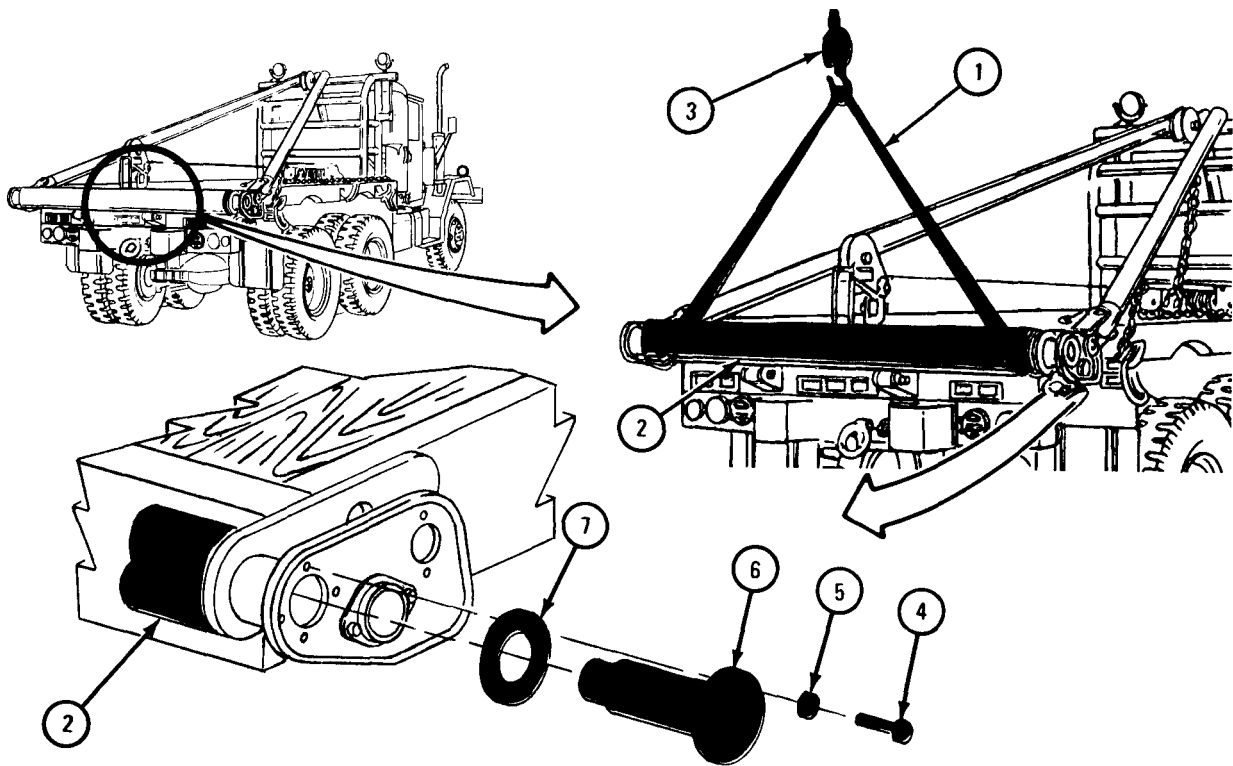

TA 083269



## FRAME 2

1. Working on right side of roller (1), takeout oil seal (2) and bearing (3).
2. Using screwdriver, unscrew and take out four screws (4). Pull out bearing seat (5).
3. Do steps 1 and 2 again for left side of roller (1) .

END OF TASK

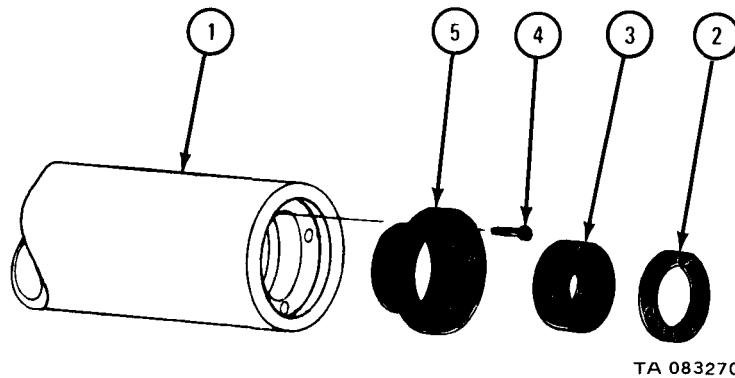

TA 083270

- c. Repair. Check for damaged parts. If parts are damaged, get new ones.
- d. Replacement.

FRAME 1

1. Working on left side of roller (1) , slide bearing seat (2) into roller and aline holes.
2. Using screwdriver, screw in and tighten four screws (3) .
3. Slide bearing (4) and then oil seal (5) into bearing seat (2) .
4. Do steps 1 through 3 again for right side of roller (1) .

GO TO FRAME 2

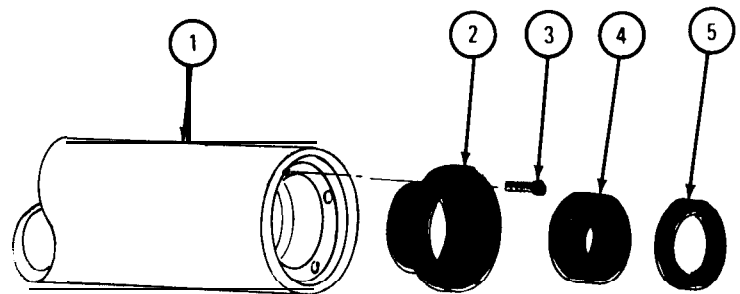

TA 083271

FRAME 2

NOTE

Make sure that oil seal and bearing stay in bearing seat.

- Soldiers 1. Using hoist (1), lift up tailboard roller (2) and place it on two auxiliary rollers (3) as shown.
- Soldier A 2. Hold tailboard roller (2) in place.
- Soldier B 3. Working on right side of tailboard roller (2), slide shim (4) on roller pin (5) and align holes.
4. Push roller pin (5) into tailboard roller (2) and align holes.
5. Using wrench, screw in and tighten four screws (6) with lockwashers (7).
6. Do steps 3 through 5 again on left side of tailboard roller (2).
7. Take off rope (8) and hoist (1).

GO TO FRAME 3

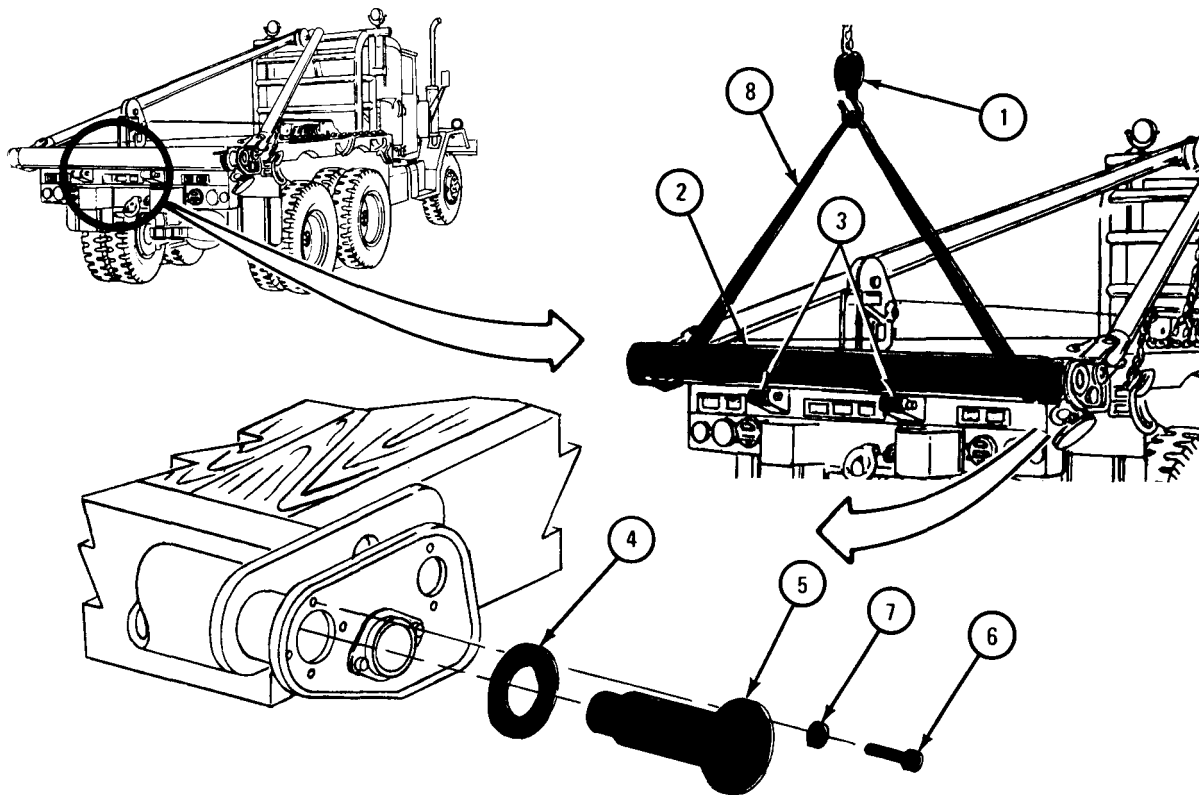

TA 083272

FRAME 3

NOTE

Follow-on Maintenance Action Required:

1. If truck has drop sides, replace them. Refer to TM 9-2320-209-10.
2. If truck has side racks, replace them. Refer to TM 9-2320-209-10.
3. If truck has tailgate, replace it. Refer to TM 9-2320-209-10.

END OF TASK

18-94. STIFFLEG JACK ASSEMBLY REMOVAL, REPAIR, AND REPLACEMENT  
(TRUCK M756A2).

NOTE

This task is the same for the right and left stiffleg jack assemblies. This task is shown for the left stiffleg jack assembly.

TOOLS : Pliers

SUPPLIES : None

PERSONNEL: One

EQUIPMENT CONDITION : Truck parked , engine off, handbrake set , wheels chocked.

a. Removal.

FRAME 1

1. Unhook and pull out safety pin (1).
2. Pull tee locking pin (2) out until stiffleg jack assembly (3) is free.
3. Pull stiffleg jack assembly (3) out of storage compartment.

GO TO FRAME 2

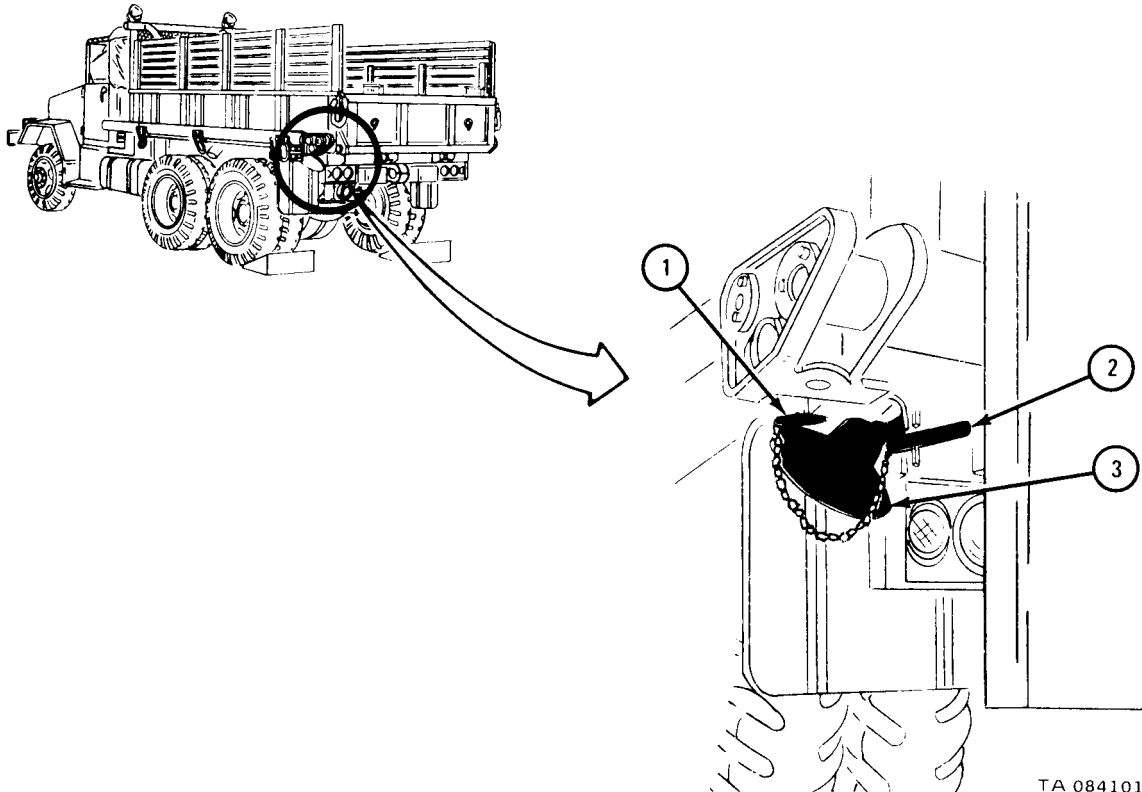

FRAME 2

1. Using pliers, take out cotter pin (1).
2. Take out pin (2). Take jack assembly off truck and put it on workbench.
3. Using pliers, takeout cotter pin (3) and takeout pin (4). Take off foot (5).
4. Pullout tee locking pin (6).
5. Pull lower leg (7) from upper leg (8).

END OF TASK

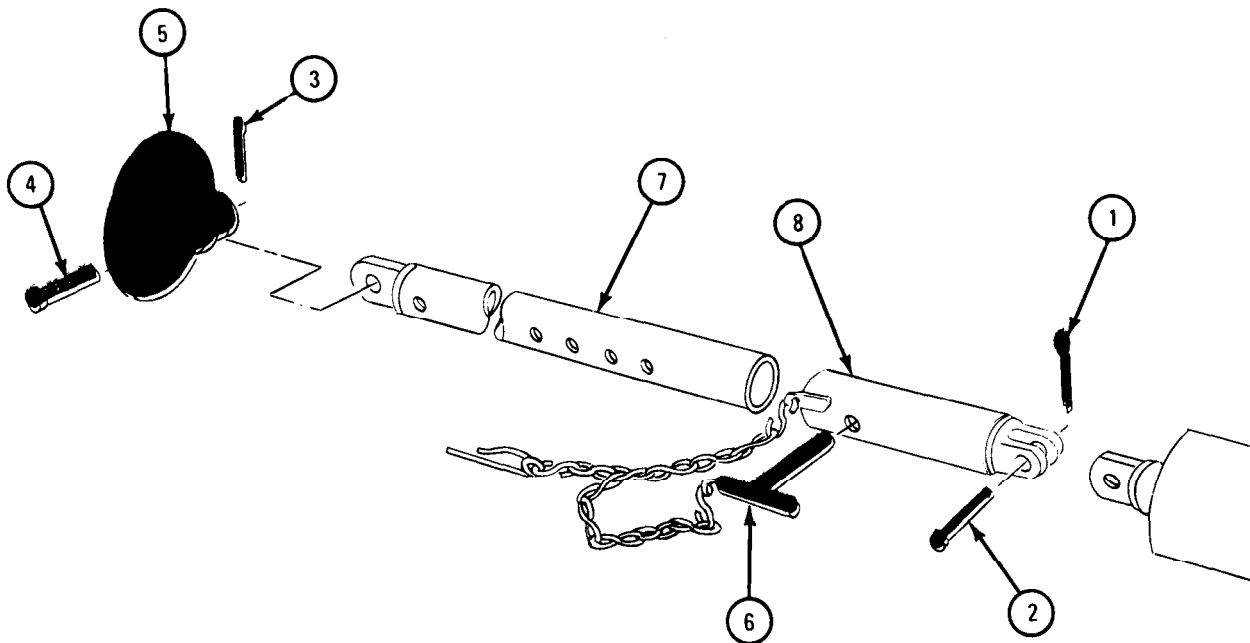

TA 084102

- b. Repair. If any parts are bent, broken or rusted through, get new parts.
- c. Replacement.

**FRAME 1**

1. Slide lower leg (1) into upper leg (2). Aline holes and put in tee locking pin (3).
2. Put foot (4) in place. Aline holes and put in pin (5).
3. Using pliers, put in and bend open ends of cotter pin (6).

GO TO FRAME 2

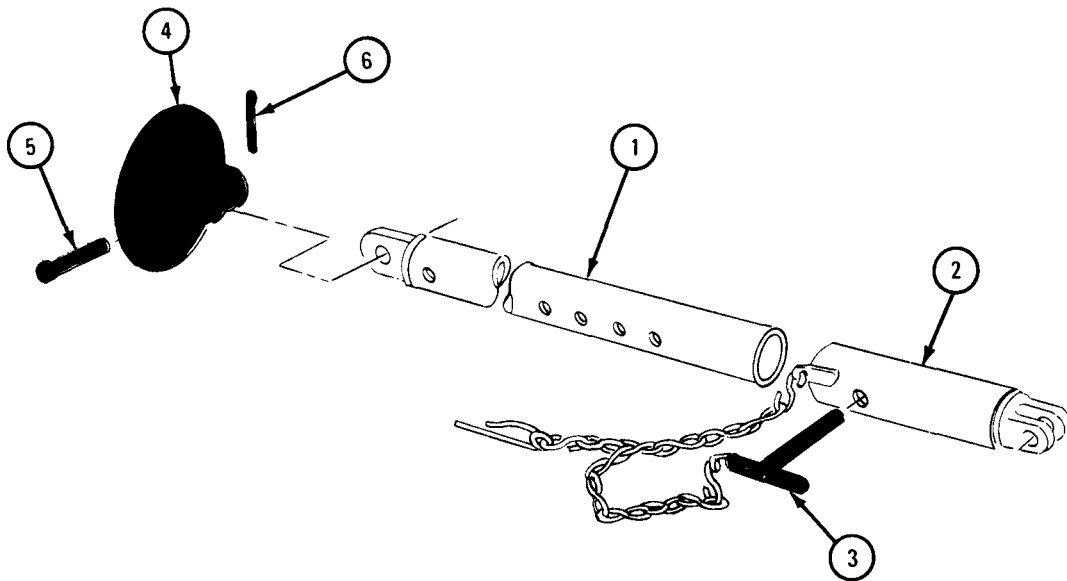

TA 084103

FRAME 2

1. Put jack assembly in place on truck. Aline holes and put in pin (1).
  2. Using pliers, put in and bend open ends of cotter pin (2).
  3. Lift jack legs (3 and 4) up to level position and push them 1 foot into storage compartment (5).
  4. Take safety pin (6) out of tee locking pin (7) and pull out tee locking pin.
  5. Push lower jack leg (3) into upper jack leg (4) and aline hole in upper jack leg with last hole in lower jack leg.
  6. Put tee locking pin (7) through holes, but do not let tee locking pin stick out other side of upper jack leg (4).
  7. Push jack legs (3 and 4) all the way into storage compartment (5).
  8. Turn tee locking pin (7) handle to up and down position and push it all the way in.
  9. Put safety pin (6) through hole in end of tee locking pin (7). Lock safety pin.
- END OF TASK

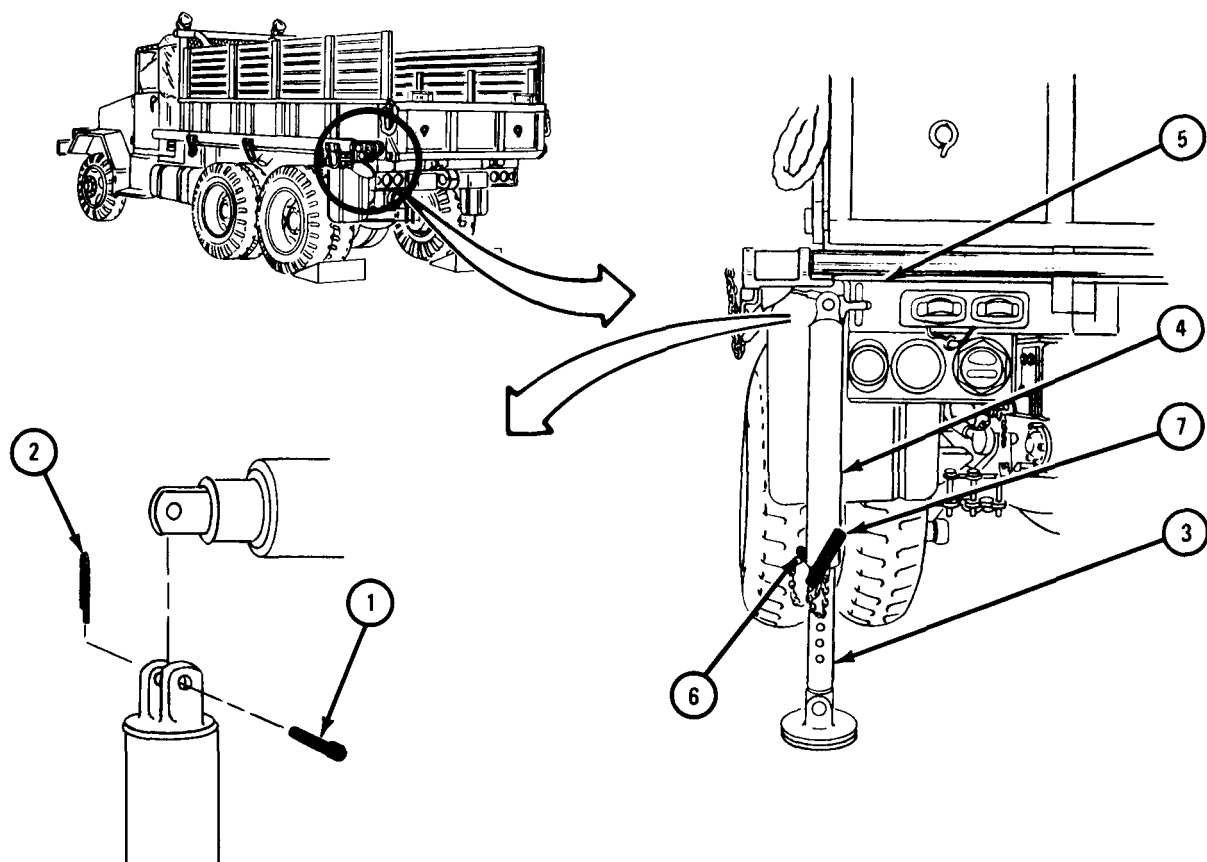

TA 084096



## 18-95. SNATCH SHEAVE REMOVAL AND REPLACEMENT (TRUCK M764)

TOOLS : Adjustable wrench

SUPPLIES : None

PERSONNEL: One

EQUIPMENT CONDITION: Truck parked, engine off, handbrake set.

a. Removal.**FRAME 1**

1. Hold sheave housing (1) and using adjustable wrench, unscrew and take out eyebolt (2).
  2. Take ring (3) off sheave housing (1) .
- END OF TASK

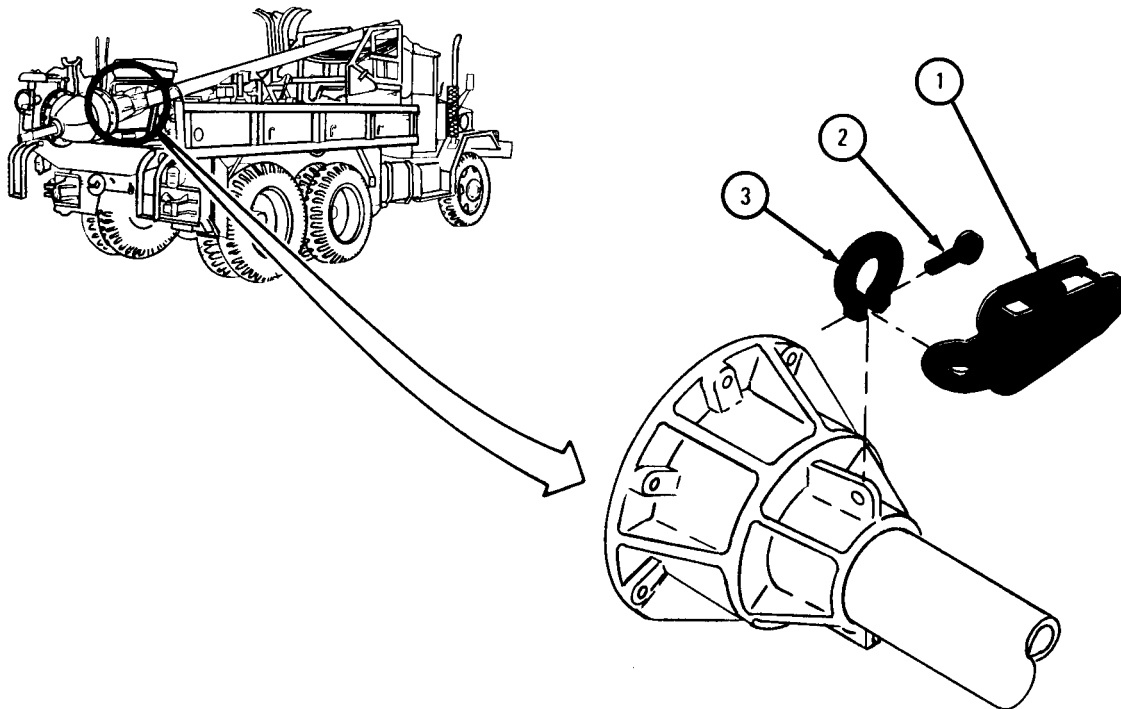

TA 085577

b. Replacement.

FRAME 1

1. Put ring (1) on sheave housing (2).
2. Put ring (1) with sheave housing (2) into place and aline screw holes (3).
3. Using adjustable wrench, screw in and tighten eyebolt (4).

END OF TASK

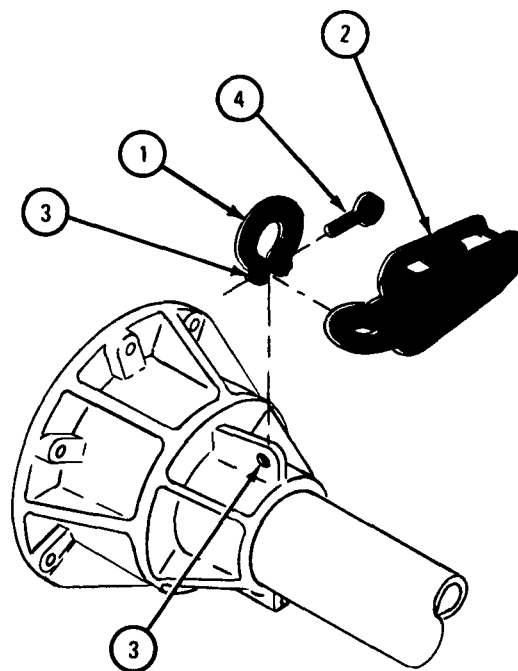
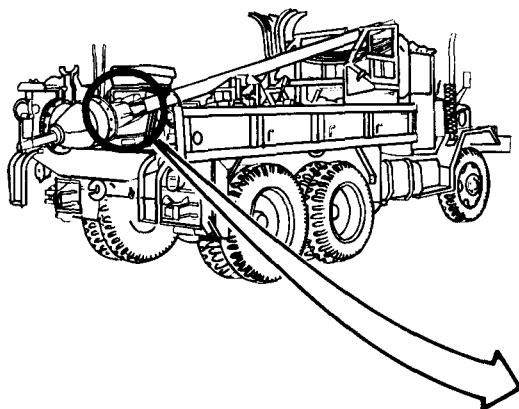

TA 085578

By Order of the Secretaries of the Army and the Air Force:

E. C. MEYER  
General, United States Army  
Chief of Staff

Official:

J. C. PENNINGTON  
Major General, United States Army  
The Adjutant General

LEW ALLEN, JR., General, USAF  
Chief of Staff

Official:

VAN L. CRAWFORD, JR., Colonel, USAF  
Director of Administration

Distribution:

To be distributed in accordance with DA Form 12-38, Organizational Maintenance requirements for 2-1/2-Ton Truck Cargo, 2-1/2-Ton Truck Van, etc.





THEN... JOT DOWN THE DOPE ABOUT IT ON THIS FORM, CAREFULLY TEAR IT OUT, FOLD IT AND DROP IT IN THE MAIL!

SOMETHING WRONG WITH THIS PUBLICATION?

FROM: (PRINT YOUR UNIT'S COMPLETE ADDRESS)  
 CDR, 1st Bn, 65th ADA  
 Attn: SP4 Jane Idone  
 Key West, FL 33040

DATE SENT \_\_\_\_\_ Date Sent In \_\_\_\_\_

PUBLICATION NUMBER  
 TM 9-2320-209-20-3-3

PUBLICATION DATE  
 27 May 81

PUBLICATION TITLE  
 ORGANIZATIONAL MAINTENANCE MANUAL

BE EXACT... PIN-POINT WHERE IT IS

PAGE NO	PARA-GRAPH	FIGURE NO	TABLE NO
18-17	18-6 c		
18-128	18-30 b		
18-389	18-73		

IN THIS SPACE TELL WHAT IS WRONG AND WHAT SHOULD BE DONE ABOUT IT:

FRAME 2, step 3. Add a sentence to read "Push windshield lock handle down."

FRAME 2 - Change illustration callouts. Reason: callouts for fusible link release spring (5) and emergency release control spring (6) are reversed.

Subparagraph a, step (1) refers to TM 9-2320-209-20. Should refer to TM 9-2320-209-10.

SAMPLE

PRINTED NAME GRADE OR TITLE AND TELEPHONE NUMBER  
 SP4 Jane Idone Autovon 222-2224

SIGN HERE  
*Jane Idone*

FILL IN YOUR  
UNIT'S ADDRESS

FOLD

DEPARTMENT OF THE ARMY

\_\_\_\_\_  
\_\_\_\_\_

OFFICIAL BUSINESS  
PENALTY FOR PRIVATE USE \$.

**SAMPLE**

POSTAGE AND FEES PAID  
DEPARTMENT OF THE ARMY  
DOD 314



TEAR ALONG PERFORATED LINE

Commander  
U.S. Army Tank-Automotive Command  
ATTN: DRSTA-MB  
Warren, MI 48090

RECOMMENDED CHANGES TO EQUIPMENT TECHNICAL PUBLICATIONS



THEN... JOT DOWN THE DOPE ABOUT IT ON THIS FORM. CAREFULLY TEAR IT OUT. FOLD IT AND DROP IT IN THE MAIL!

# SOMETHING WRONG WITH THIS PUBLICATION?

FROM (PRINT YOUR UNIT'S COMPLETE ADDRESS)

DATE SENT

PUBLICATION NUMBER

TM 9-2320-209-20-3-3

PUBLICATION DATE

27 May 81

PUBLICATION TITLE

ORGANIZATIONAL MAINTENANCE MANUAL

BE EXACT. PIN-POINT WHERE IT IS

PAGE NO	PARA-GRAPH	FIGURE NO	TABLE NO

IN THIS SPACE TELL WHAT IS WRONG AND WHAT SHOULD BE DONE ABOUT IT:

PRINTED NAME GRADE OR TITLE AND TELEPHONE NUMBER

SIGN HERE

FILL IN YOUR  
UNIT'S ADDRESS

FOLD BACK

DEPARTMENT OF THE ARMY

\_\_\_\_\_  
\_\_\_\_\_

OFFICIAL BUSINESS  
PENALTY FOR PRIVATE USE \$300

POSTAGE AND FEES PAID  
DEPARTMENT OF THE ARMY  
DOD 314



TEAR ALONG PERFORATED LINE

Commander  
U.S. Army Tank-Automotive Command  
ATTN: DRSTA-MB  
Warren, MI 48090



RECOMMENDED CHANGES TO EQUIPMENT TECHNICAL PUBLICATIONS



THEN... JOT DOWN THE DOPE ABOUT IT ON THIS FORM, CAREFULLY TEAR IT OUT, FOLD IT AND DROP IT IN THE MAIL!

SOMETHING WRONG WITH THIS PUBLICATION?

FROM (PRINT YOUR UNIT'S COMPLETE ADDRESS)

DATE SENT

PUBLICATION NUMBER

TM 9-2320-209-20-3-3

PUBLICATION DATE

27 May 81

PUBLICATION TITLE

ORGANIZATIONAL MAINTENANCE MANUAL

BE EXACT. PIN-POINT WHERE IT IS

PAGE NO

PARA-GRAPH

FIGURE NO

TABLE NO

IN THIS SPACE TELL WHAT IS WRONG AND WHAT SHOULD BE DONE ABOUT IT:

PRINTED NAME GRADE OR TITLE AND TELEPHONE NUMBER

SIGN HERE

FILL IN YOUR  
UNIT'S ADDRESS

FOLD BACK

TEAR ALONG PERFORATED LINE

DEPARTMENT OF THE ARMY

POSTAGE AND FEES PAID  
DEPARTMENT OF THE ARMY  
DOD 314



OFFICIAL BUSINESS  
PENALTY FOR PRIVATE USE \$300

Commander  
U.S. Army Tank-Automotive Command  
ATTN: DRSTA-MB  
Warren, MI 48090

RECOMMENDED CHANGES TO EQUIPMENT TECHNICAL PUBLICATIONS



THEN... JOT DOWN THE DOPE ABOUT IT ON THIS FORM. CAREFULLY TEAR IT OUT. FOLD IT AND DROP IT IN THE MAIL.

**SOMETHING WRONG WITH THIS PUBLICATION?**

FROM (PRINT YOUR UNIT'S COMPLETE ADDRESS)

DATE SENT

PUBLICATION NUMBER

TM 9-2320-209-20-3-3

PUBLICATION DATE

27 May 81

PUBLICATION TITLE

ORGANIZATIONAL MAINTENANCE MANUAL

BE EXACT PIN-POINT WHERE IT IS

PAGE NO

PARA-GRAPH

FIGURE NO

TABLE NO

IN THIS SPACE TELL WHAT IS WRONG AND WHAT SHOULD BE DONE ABOUT IT:

PRINTED NAME GRADE OR TITLE AND TELEPHONE NUMBER

SIGN HERE

FILL IN YOUR  
UNIT'S ADDRESS

FOLD BACK

DEPARTMENT OF THE ARMY

POSTAGE AND FEES PAID  
DEPARTMENT OF THE ARMY  
DOD 314



TEAR ALONG PERFORATED LINE

OFFICIAL BUSINESS  
PENALTY FOR PRIVATE USE \$300

Commander  
U.S. Army Tank-Automotive Command  
ATTN: DRSTA-MB  
Warren, MI 48090

## THE METRIC SYSTEM AND EQUIVALENTS

### LINEAR MEASURE

1 Centimeter = 10 Millimeters = 0.01 Meters = 0.3937 Inches  
 1 Meter = 100 Centimeters = 1000 Millimeters = 39.37 Inches  
 1 Kilometer = 1000 Meters = 0.621 Miles

### SQUARE MEASURE

1 Sq Centimeter = 100 Sq Millimeters = 0.155 Sq Inches  
 1 Sq Meter = 10,000 Sq Centimeters = 10.76 Sq Feet  
 1 Sq Kilometer = 1,000,000 Sq Meters = 0.386 Sq Miles

### WEIGHTS

1 Gram = 0.001 Kilograms = 1000 Milligrams = 0.035 Ounces  
 1 Kilogram = 1000 Grams = 2.2 Lb  
 1 Metric Ton = 1000 Kilograms = 1 Megagram = 1.1 Short Tons

### CUBIC MEASURE

1 Cu Centimeter = 1000 Cu Millimeters = 0.06 Cu Inches  
 1 Cu Meter = 1,000,000 Cu Centimeters = 35.31 Cu Feet

### LIQUID MEASURE

1 Milliliter = 0.001 Liters = 0.0338 Fluid Ounces  
 1 Liter = 1000 Milliliters = 33.82 Fluid Ounces

### TEMPERATURE

$5/9 (^{\circ}\text{F} - 32) = ^{\circ}\text{C}$   
 212<sup>o</sup> Fahrenheit is equivalent to 100<sup>o</sup> Celsius  
 90<sup>o</sup> Fahrenheit is equivalent to 32.2<sup>o</sup> Celsius  
 32<sup>o</sup> Fahrenheit is equivalent to 0<sup>o</sup> Celsius  
 $9/5 \text{ C}^{\circ} + 32 = \text{F}^{\circ}$

### APPROXIMATE CONVERSION FACTORS

<u>TO CHANGE</u>	<u>TO</u>	<u>MULTIPLY BY</u>
Inches . . . . .	Centimeters . . . . .	2.540
Feet . . . . .	Meters . . . . .	0.305
Yards . . . . .	Meters . . . . .	0.914
Miles . . . . .	Kilometers . . . . .	1.609
Square Inches . . . . .	Square Centimeters . . . . .	6.451
Square Feet . . . . .	Square Meters . . . . .	0.093
Square Yards . . . . .	Square Meters . . . . .	0.836
Square Miles . . . . .	Square Kilometers . . . . .	2.590
Acres . . . . .	Square Hectometers . . . . .	0.405
Cubic Feet . . . . .	Cubic Meters . . . . .	0.028
Cubic Yards . . . . .	Cubic Meters . . . . .	0.765
Fluid Ounces . . . . .	Milliliters . . . . .	29.573
Pints . . . . .	Liters . . . . .	0.473
Quarts . . . . .	Liters . . . . .	0.946
Gallons . . . . .	Liters . . . . .	3.785
Ounces . . . . .	Grams . . . . .	28.349
Pounds . . . . .	Kilograms . . . . .	0.454
Short Tons . . . . .	Metric Tons . . . . .	0.907
Pound-Feet . . . . .	Newton-Meters . . . . .	1.356
Pounds per Square Inch . . . . .	Kilopascals . . . . .	6.895
Miles per Gallon . . . . .	Kilometers per Liter . . . . .	0.425
Miles per Hour . . . . .	Kilometers per Hour . . . . .	1.609

<u>TO CHANGE</u>	<u>TO</u>	<u>MULTIPLY BY</u>
Centimeters . . . . .	Inches . . . . .	0.394
Meters . . . . .	Feet . . . . .	3.280
Meters . . . . .	Yards . . . . .	1.094
Kilometers . . . . .	Miles . . . . .	0.621
Square Centimeters . . . . .	Square Inches . . . . .	0.155
Square Meters . . . . .	Square Feet . . . . .	10.764
Square Meters . . . . .	Square Yards . . . . .	1.196
Square Kilometers . . . . .	Square Miles . . . . .	0.386
Square Hectometers . . . . .	Acres . . . . .	2.471
Cubic Meters . . . . .	Cubic Feet . . . . .	35.315
Cubic Meters . . . . .	Cubic Yards . . . . .	1.308
Milliliters . . . . .	Fluid Ounces . . . . .	0.034
Liters . . . . .	Pints . . . . .	2.113
Liters . . . . .	Quarts . . . . .	1.057
Liters . . . . .	Gallons . . . . .	0.264
Grams . . . . .	Ounces . . . . .	0.035
Kilograms . . . . .	Pounds . . . . .	2.205
Metric Tons . . . . .	Short Tons . . . . .	1.102
Newton-Meters . . . . .	Pound-Feet . . . . .	0.738
Kilopascals . . . . .	Pounds per Square Inch . . . . .	0.145
Kilometers per Liter . . . . .	Miles per Gallon . . . . .	2.354
Kilometers per Hour . . . . .	Miles per Hour . . . . .	0.621

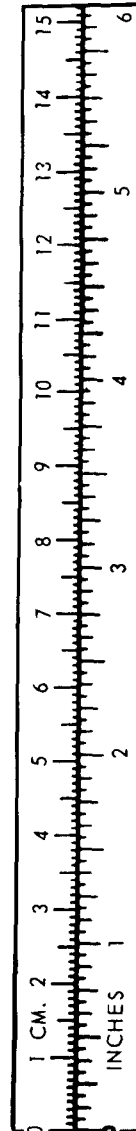

TAO89991

